



20th

Enabling The Development And Implementation of Digital Twins

Proceedings of the 20th
International Conference on
Construction Applications
of Virtual Reality

Edited By:

Nashwan Dawood
Farzad Rahimian
Saleh Seyedzadeh
Moslem Sheikhhoshkar

30th Sep -2 Oct 2020



Teesside University
Southfield Rd, Middlesbrough
United Kingdom

Enabling the Development and Implementation of Digital Twins

Proceedings of the 20th International
Conference on Construction Applications of
Virtual Reality

Editors

Nashwan Dawood
Teesside University
Middlesbrough, UK

Farzad Pour Rahimian
Teesside University
Middleborough, UK

Saleh Seyedzadeh
University of Strathclyde
Glasgow, UK

Moslem Sheikhhoshkar
Iran University of Science and
Technology
Tehran, Iran

ISBN 978-0-9927161-2-7 CONVR2020

Preface

Welcome to the 20th International Conference on Construction Applications of Virtual Reality (CONVR 2020). This year we are meeting on-line due to the current Coronavirus pandemic. The overarching theme for CONVR2020 is "Enabling the development and implementation of Digital Twins".

CONVR is one of the world-leading conferences in the areas of virtual reality, augmented reality and building information modelling. Each year, more than 100 participants from all around the globe meet to discuss and exchange the latest developments and applications of virtual technologies in the architectural, engineering, construction and operation industry (AECO). The conference is also known for having a unique blend of participants from both academia and industry.

This year, with all the difficulties of replicating a real face to face meetings, we are carefully planning the conference to ensure that all participants have a perfect experience. We have a group of leading keynote speakers from industry and academia who are covering up to date hot topics and are enthusiastic and keen to share their knowledge with you. CONVR participants are very loyal to the conference and have attended most of the editions over the last eighteen editions. This year we are welcoming numerous first timers and we aim to help them make the most of the conference by introducing them to other participants.

Middlesbrough, UK
September 2020

Nashwan Dawood
Farzad Pour Rahimian
Saleh Seyedzadeh
Moslem Sheikhhoshkar

Contents

Part 1. Introduction

- 1 Enabling the development and implementation of Digital Twins..... 1**

Nashwan Dawood, Farzad Rahimian, Saleh Seyedzadeh & Moslem Sheikhhoshkar

Part 2. AR & VR, Serious Games & Wearables

- 2 Superimposing Building Information Models
in Augmented Reality 11**

Vishak Dudhee & Vladimir Vukovic

- 3 Active Personalized Training of Construction Safety
Using Run Time Data Collection in Virtual Reality..... 19**

Alex Solberg, Jens K. Hognestad, Olga Golovina, Jochen Teizer

- 4 Developing a Mixed-Reality Based Application
for Bridge Inspection and Maintenance..... 31**

Duy Cuong Nguyen, Chang Su Shim, The Quan Nguyen, Ruoyu Jin, Chi Ho Jeon

- 5 Vision-based Construction Site Monitoring: A Review
from Construction Management Point of View..... 44**

Aritra Pal & Shang-Hsien Hsieh

- 6 AR-based and User-Centered Approach to the On-site
Design Decision Support for Building Remodel Projects..... 56**

Sanghoon Lee, Jinsung Kim, Dahngyu Cho & Jin-Kook Lee

- 7 Improving Construction Risk Assessment via Integrating
Building Information Modeling (BIM) with Virtual Reality (VR)..... 64**

Rolim A. L, Valente G. A., Keskin B

- 8 Collaborative Scheduling with 4D Extended to
Virtual Reality..... 73**

Mikael Viklund Tallgren, Mattias Roupé, Mikael Johansson

9	Virtual Reality in Construction Health and Safety Education: Students Experience through Video Elicitation - A Pilot Study.....	86
	Mark Swallow and Sam Zulu	
10	The Application of Virtual Reality in Construction Education: A South Africa Case Study.....	95
	Nishani Harinarain	
11	Using Virtual Reality to Evaluate the Impact of Dispersion of Elements on Kinetic Façade.....	104
	Mojgan Rezakhani and Sung-Ah Kim	
12	The House Configurator: Configuring BIM Variables Using Game Interfaces.....	116
	Lilia Potseluyko Amobi and Farzad Rahimian	

Part 3. Digital Twins

13	Digital Twin Uses Classification System for Urban Planning & Infrastructure Program Management.....	128
	Ramy Al-Sehrawy, Bimal Kumar and Richard Watson	
14	Digital Twin Driven Musculoskeletal Injury Prevention System.....	139
	Omobolanle Ogunseiju, Johnson Olayiwola & Abiola Akanmu	
15	Holographic Learning Environment for Bridging the Technical Skill Gap of the Future Smart Construction Engineering Students.....	151
	Omobolanle Ogunseiju, Abiola Akanmu, and Diana Bairakt	
16	Immersive Video Capture Technology for Construction Management Education.....	163
	Alireza Shojaei, Saeed Rokoei, Lee Carson, George Ford	

Part 4. Building Information Modelling

17	Converting Open Standard CAD Formats Into Decentralised Common Data Environment.....	174
	Stephen Oliver & Farzad Pour Rahimian & Nashwan Dawood & Sergio Rodriguez	
18	A Proposal of a Site Object Library for Construction Workers' Safety Training Using BIM-based Immersive Virtual Reality.....	184
	Vito Getuli, Pietro Capone, Alessandro Bruttini & Tommaso Sorbi	

19	Automated Progress Monitoring via Fusion of 4D BIM and AI through Schedule Updating by Convolutional Networks and a Specialized Labelled Dataset for the Construction Components.....	196
	Reza Hedayat Nejad, Ali Ghaffarianhoseini & Amirhosein Ghaffarianhoseini	
20	Automatic Generation of 3D Building Models for BIM by Polygon Partitioning and Rectification.....	209
	Kenichi Sugihara, Zhenjiang Shen & Takahiro Murase	
21	Automated BIM-based Formwork Quantity Take Off.....	220
	Yasar Cepni, Asli Akcamete & Ralf Klein	
22	Developing an Intensional Definition Satisfying the Philosophy of Definitions to Appraise the Theory of BIM.....	228
	Githyon Prabhu & Henry Abanda	
23	Employing BIM-based Geostatistical Analysis to Design a Monitoring Arrangement.....	242
	Mahmoudi E & Yilmaz F & König M	
24	Illuminating the Ideological Developments of BIM to Appraise the Terminology BIM.....	251
	Githyon Prabhu & Henry Abanda	
25	Towards BIM-Based Assembly Capacity Analysis for Community Construction Site Planning and Simulation.....	264
	Wei Zhou & Praveen Pushpala	

Part 5. Monitoring & Inspection

26	Indrone: Visualizing Drone Flight Patterns for Indoor Building Inspection Tasks.....	273
	Ricardo Eiris, Gilles Albeaino, Masoud Gheisari, Brett Benda & Randi Faris	
27	Visual Dust Emission Monitoring for Construction Activities.....	283
	Ruoxin Xiong & Pingbo Tang	
28	Non-monotonic Reasoning for Automated Progress Analysis of Construction Operations.....	292
	Karsten W. Johansen, Rasmus O. Nielsen, Carl Schultz, Jochen Teizer	
29	Automatic Generation of 3D Terrain Models for Debrics Flow Simulation.....	304
	Takahiro Murase, Kenichi Sugihara & Zhenjiang Shen	

Part 6. Artificial Intelligence

- 30 Web-based Construction Collaboration Tools:
Text Mining of User Perceptions..... 316**
Mahmuda Chowdhury, M. Reza Hosseini, Igor Martek,
David John Edwards & Tandeep Singh
- 31 An Image Feature Classification System for Piers
Based on Semantic Segmentation with Deep Learning..... 325**
Natthapol Saovana, Nobuyoshi Yabuki, and Tomohiro Fukuda
- 32 Awareness of Big Data concept in the Dominican Republic
Construction Industry: An Empirical Study..... 336**
Paola F. Reyes-Veras, Suresh Renukappa and Subashini Suresh
- 33 Facilitating Information Exchange for 3D Retrofit Models
of Existing Assets Using Semantic Web Technologies..... 350**
Farhad Sadeghineko & Bimal Kumar
- 34 Conceptualizing 3D Model Development and Validation
via the Integration of Speech Cognitive Processing..... 364**
Andrew Pidgeon & N Dawood
- 35 Image-based Verification and Mapping of Physical
Barrier for Wheelchairs..... 372**
Rio Takahashi, Hiroshige Dan, and Yoshihiro Yasumuro

Part1. Introduction

ENABLING THE DEVELOPMENT AND IMPLEMENTATION OF DIGITAL TWIN

Nashwan Dawood

Teesside University, Middlesbrough, UK

Farzad Rahimian

Teesside University, Middlesbrough, UK

Saleh Seyedzadeh

University of Strathclyde, Glasgow, UK

Moslem Sheikhhoshkar

Iran University of Science & Technology, Tehran, Iran

Built environment has been perennially caught up in low productivity conundrum for a long time. This is despite its significant impact on industrial employment (i.e. over 6.6% contribution) and representation of 9.8% of the UK's Gross Domestic Product (Rhodes, 2019). Poor collaborative processes through effective information exchanges has been identified as a major reason for this (Crotty, 2013; Kumar, 2015). Besides, the knowledge gap between design and construction has also been cited as a major contributor to this discontinuity (Abrishami *et al.*, 2014; Fruchter *et al.*, 2016; Goulding and Pour Rahimian, 2019; Goulding *et al.*, 2015; Pour Rahimian *et al.*, 2019; Pour Rahimian *et al.*, 2008; Pour Rahimian *et al.*, 2011).

Over the years, leading experts from industry and academia (Egan, 1998; Latham, 1994) have contributed to the dissection of the drivers behind this and suggest solutions to address these issues. However, it has taken major developments in digital technologies like the internet, project extranets, building information modelling (BIM), IoT among others to generate the kind of optimism that the industry has never experienced before. Built environment is not alone in sharing the excitement around these technologies. These technologies have captured the imagination of just about every industrial sector. Of course, no technology can result in addressing the challenges of any industry on its own. A set of complimentary processes (Goulding *et al.*, 2015; Kumar, 2015) need to be developed in tandem for the technologies to be effective enablers of change. Quite encouragingly, such processes have been developed recently particularly in relation to information management and collaborative working in the built environment sector. These are positive developments and whose veracity and effectiveness will be tested over the next few years.

Meanwhile, the wider world (including the built environment) is experiencing a kind of paradigm shift due to the emergence of the industry 4.0 revolution. Recent technological and other process-based advances and innovative technologies in the built environment mentioned above have a key role to play in this process. As widely reported in the popular and scientific media, the nine pillars supporting Industry 4.0 are 1) The Internet of Things, 2) Big Data, 3) Augmented Reality, 4) Advanced Visualisation, VR and Simulation, 5) Additive Manufacturing, 6) System Integration, 7) Cloud Computing, 8) Autonomous Systems, and 9) Cybersecurity.

In case of the built environment sector, these nine pillars can be said to be underpinned by BIM, widely regarded as the tool of choice to address key issues as industry fragmentation,

value-driven solutions, decision making, client engagement, and design/process flow to name but a few. Therefore, it could be argued that the Construction 4.0 has ten pillars which includes the nine Industry 4.0 pillars and BIM. Exemplars from other industries such as automotive, aerospace and oil and gas currently demonstrate the power and application of these technologies. However, built environment has only just started to recognise terms such as “golden key” and “golden thread” as part of BIM processes and workflows. Construction 4.0 offers a portfolio of potential solutions to bridge the knowledge and information gaps between design, construction and operations (Newman *et al.*, 2020; Sawhney *et al.*, 2020).

This has led to the emergence of a series of cutting edge technologies in the AEC realm including but not limited to virtual reality-based collaboration technologies (Pour Rahimian *et al.*, 2019), artificial intelligence-based optimisation (Pilechiha *et al.*, 2020), data-driven decision support (Seyedzadeh *et al.*, 2019), smart data modelling (Pilechiha *et al.*, 2020), blockchain and distributed ledger technologies (Elghaish *et al.*, 2020), and computer vision and graphics (Moshtaghian *et al.*, 2020; Pour Rahimian *et al.*, 2020). Where for example, these advancements are now able to assist decision-making to predict the cost and performance of optimal design proposals (Elghaish and Abrishami, 2020).

Advancements in cryptography and read-only data management optimisation are paving the way for fully-fledged distributed ledger technologies for digital twinning and asset lifecycle management. Previous research has demonstrated real-time centralised solutions for OpenBIM. Collectively, these developments are forcing a paradigm shift in design from asynchronous to real-time data exchanges which are impervious to repudiation, ultimately improving interorganisational perceptions of social presence (Oliver, 2019) and imbuing confidence in the design shift expected of OpenBIM.

CONVR is one of the world-leading conferences in the areas of virtual reality, augmented reality and building information modelling. Each year, more than 100 participants from all around the globe meet to discuss and exchange the latest developments and applications of virtual technologies in the architectural, engineering, construction and operation industry (AECO). The conference is also known for having a unique blend of participants from both academia and industry. The overarching theme for CONVR2020 is "Enabling the development and implementation of Digital Twins."

This year, with all the difficulties of replicating a real face to face meetings, we are carefully planning the conference to ensure that all participants have a perfect experience. We have a group of leading keynote speakers from industry and academia who are covering up to date hot topics and are enthusiastic and keen to share their knowledge with you. CONVR participants are very loyal to the conference and have attended most of the editions over the last eighteen editions. This year we are welcoming numerous first timers and we aim to help them make the most of the conference by introducing them to other participants.

This proceeding brings together thirty-five papers related to Construction 4.0 topics in six parts. In part one of the proceeding, an introduction has been given. In addition, Papers have been presented in five parts including AR & VR, Serious Games & Wearables, Digital Twins, Building Information Modelling (BIM), Monitoring & Inspection and Artificial Intelligence.

In part two, AR & VR, Serious Games & Wearables, eleven papers have been presented: (Dudhee and Vukovic, 2020) reviewed and analyses the BIM model superimposing techniques in AR. (Solberg *et al.*, 2020) presented a framework for the generation and automated assessment of such data in VR. (Nguyen *et al.*, 2020) presented an application of MR-based

system called HoloBridge to enhance and facilitate bridge inspection and maintenance. (Pal and Hsieh, 2020) reviewed computer vision research for the construction management application through bibliometric, scientometric, and qualitative content analyses. (Lee *et al.*, 2020) described how user can change the conceptual design visualized at on-site using a private design object server, specifically to choose candidate design among lots of alternatives. (L *et al.*, 2020) provided a novel BIM-enabled risk assessment approach via leveraging synergies between BIM processes and virtual reality. (Tallgren *et al.*, 2020) presented a prototype software for planning and scheduling where the production-schedule is created directly from the model in a lean construction Last Planner manner from the building components. (Swallow and Zulu, 2020) explored the reflective experience of higher education students using VR specifically for health and safety education/training. (Harinarain, 2020) focused on the concept of applying virtual reality technology in tertiary construction education in South Africa by providing an analysis of students' perceptions and enthusiasm for its implementation. (Rezakhani and Kim, 2020) investigated an aspect of kinetic façade based on patterns for meeting arrangement components in case of motion and structure pressure. (Amobi and Rahimian, 2020) studied the product personalisation process of Timber Frame Self-Building Housing Sector by observing a design team communication with clients.

In part three, Digital Twins, four papers have been presented:

(Al-Sehrawy *et al.*, 2020) sought to formulate a seed for a Digital Twin Uses Classification System (DTUCS) within the field of urban and city infrastructure program management. (Ogunseiju *et al.*, 2020b) presented a framework for augmenting construction workspaces with digital twin representation of real-time ergonomic exposures of construction workers to facilitate self-management of the risks. (Ogunseiju *et al.*, 2020a) suggested the development of a holographic learning environment that can afford learners an experiential opportunity to acquire competencies for implementing sensing systems on construction projects. (Shojaei *et al.*, 2020) investigated the incorporation of 360° and 180° 3D immersive videos within a construction education class.

In part four, Building Information Modelling (BIM), ten papers have been presented:

(Oliver *et al.*, 2020) proposed a method for creating BIM 3c-ready common data environments from existing open standards. (Getuli *et al.*, 2020) suggested a BIM-based Site Object Library oriented to the production of VR safety training experiences. (Nejad *et al.*, 2020) proposed a novel method of automatically updating schedules in construction projects by accessing the schedules, and comparing the WBS with real progress in on the site through convolutional neural networks. (Sugihara *et al.*, 2020) presented the new methodology for partitioning and rectifying a building polygon for automatic generation. (Cepni *et al.*, 2020) described how the extraction of formwork quantities and the creation of formwork models can be automated with Autodesk Revit Dynamo. (Prabhu and Abanda, 2020a) tackled the fundamental concepts of BIM theory deductively by employing analytical research while combining both qualitative and quantitative methods. (E *et al.*, 2020) developed a concept with geostatistical interpolation methods that recognizes the interaction between the exploratory data and qualify the uncertainties of the obtained digital soil model. (Prabhu and Abanda, 2020b) established the critical fitness of the terminology BIM by explicating the ideological development of this terminology and definitions to facilitate the context-independent view of the complicated truth without reinventing BIM once again. (Zhou and Pushpala, 2020) discussed 3D BIM model adoption for erection sequence creation through the relationship analysis between crane lifting capacity and precast concrete component's attributes for low-rise building construction. (Hamidavi and Abrishami, 2020) proposed a proof of concept prototype aims at generating computational analytical processes, encapsulated in the form of Visual Programming Language

(VPL) within Dynamo/Revit in which it enables the early-stage design of structures, and generates different alternative structural solutions in Robot Structural Analysis.

In part five, Monitoring & Inspection, four papers have been presented:

(Eiris *et al.*, 2020) focused on exploring the visual representation of human behaviors performing indoor building inspection flight operations using drones. (Xiong and Tang, 2020) examined an image-based dust emission monitoring method for construction activities. (Johansen *et al.*, 2020) investigated large data sets, using Ultra-Wideband (UWB) sensing, that contain real-time, mobile resource location tracking data from very dynamic construction environments. (Murase *et al.*, 2020) used 3D building models placed on the 3D terrain model in which massive moving elements are added for flow simulations.

In part six, Artificial Intelligence, six papers have been presented:

(Chowdhury *et al.*, 2020) attempted to collate and analyze end-users' perceptions of collaborative tools through quantitative text-mining and content analysis methods. (Saovana *et al.*, 2020) proposed the use of a deep convolutional neural network combining with Delaunay triangulation to automatically classify the features of interest. (Reyes-Veras *et al.*, 2020) addressed the level of awareness identified as the first step towards implementation of the BD Concept within the construction industry of Dominican Republic (DR). (Sadeghineko and Kumar, 2020) presented a framework for generating semantically enriched 3D retrofit models for existing buildings by utilising the Resource Description Framework (RDF). (Pidgeon and Dawood, 2020) introduced and discussed a conceptual methodology that incorporates ML algorithms to assist in the production of 3D models. (Takahashi *et al.*, 2020) addressed a barrier verification system that is easy to use and easy to understand for facility managers to maintain and manage barrier-free facilities.

REFERENCES

- Abrishami, S., Goulding, J., Rahimian, F. P., & Ganah, A. (2014). Integration of BIM and generative design to exploit AEC conceptual design innovation. *Information Technology in Construction*, 19, 350-359.
- Al-Sehrawy, R., Kumar, B., & Watson, R. (2020). Digital Twin Uses Classification System for Urban Planning & Infrastructure Program Management. In N. Dawood, F. Rahimian, S. Seyedzadeh, & M. Sheikhhoshkar (Eds.), *Proceedings of 20th International Conference on Construction Application of Virtual Reality* (pp. 128-138). Middlesbrough, UK: Teesside University Press.
- Amobi, L. P., & Rahimian, F. (2020). The House Configurator: Configuring BIM Variables Using Game Interfaces. In N. Dawood, F. Rahimian, S. Seyedzadeh, & M. Sheikhhoshkar (Eds.), *Proceedings of 20th International Conference on Construction Application of Virtual Reality* (pp. 116-126). Middlesbrough, UK: Teesside University Press.
- Cepni, Y., Akcamete, A., & Klein, R. (2020). Automated BIM-based Formwork Quantity Take Off. In N. Dawood, F. Rahimian, S. Seyedzadeh, & M. Sheikhhoshkar (Eds.), *Proceedings of 20th International Conference on Construction Application of Virtual Reality* (pp. 220-227). Middlesbrough, UK: Teesside University Press.
- Chowdhury, M., Hosseini, M. R., Martek, I., Edwards, D. J., & Singh, T. (2020). Web-based Construction Collaboration Tools: Text Mining of User Perceptions. In N. Dawood, F. Rahimian, S. Seyedzadeh, & M. Sheikhhoshkar (Eds.), *Proceedings of 20th*

- International Conference on Construction Application of Virtual Reality* (pp. 316-324). Middlesbrough, UK: Teesside University Press.
- Crotty, R. (2013). *The impact of building information modelling: transforming construction*. London: Routledge.
- Dudhee, V., & Vukovic, V. (2020). Superimposing Building Information Models in Augmented Reality In N. Dawood, F. Rahimian, S. Seyedzadeh, & M. Sheikhhoshkar (Eds.), *Proceedings of 20th International Conference on Construction Application of Virtual Reality* (pp. 11-18). Middlesbrough, UK: Teesside University Press.
- E, M., F, Y., & M, K. (2020). Employing BIM-based Geostatistical Analysis to Design a Monitoring Arrangement. In N. Dawood, F. Rahimian, S. Seyedzadeh, & M. Sheikhhoshkar (Eds.), *Proceedings of 20th International Conference on Construction Application of Virtual Reality* (pp. 242-250). Middlesbrough, UK: Teesside University Press.
- Egan, J. (1998). *Rethinking construction*. London: Department of Environment, Transport and the Region.
- Eiris, R., Albeaino, G., Gheisari, M., Benda, B., & Faris, R. (2020). Indrone: Visualizing Drone Flight Patterns for Indoor Building Inspection Tasks. In N. Dawood, F. Rahimian, S. Seyedzadeh, & M. Sheikhhoshkar (Eds.), *Proceedings of 20th International Conference on Construction Application of Virtual Reality* (pp. 273-282). Middlesbrough, UK: Teesside University Press.
- Elghaish, F., & Abrishami, S. (2020). Developing a framework to revolutionise the 4D BIM process: IPD-based solution. *Construction Innovation*.
- Elghaish, F., Abrishami, S., & Hosseini, M. R. (2020). Integrated project delivery with blockchain: An automated financial system. *Automation in Construction*, 114, 103182. doi:<https://doi.org/10.1016/j.autcon.2020.103182>
- Fruchter, R., Herzog, S., Hallermann, N., & Morgenthal, G. (2016). *Drone Site Data for Better Decisions in AEC Global Teamwork*. Paper presented at the 16th International Conference on Computing in Civil and Building Engineering, Osaka.
- Getuli, V., Capone, P., Bruttini, A., & Sorbi, T. (2020). A Proposal of a Site Object Library for Construction Workers' Safety Training Using BIM-based Immersive Virtual Reality. In N. Dawood, F. Rahimian, S. Seyedzadeh, & M. Sheikhhoshkar (Eds.), *Proceedings of 20th International Conference on Construction Application of Virtual Reality* (pp. 184-195). Middlesbrough, UK: Teesside University Press.
- Goulding, J. S., & Pour Rahimian, F. (2019). *Offsite Production and Manufacturing for Innovative Construction: People, Process and Technology*: Routledge.
- Goulding, J. S., Pour Rahimian, F., Arif, M., & Sharp, M. D. (2015). New offsite production and business models in construction: priorities for the future research agenda. *Architectural Engineering and Design Management*, 11(3), 163-184. doi:10.1080/17452007.2014.891501
- Hamidavi, T., & Abrishami, S. (2020). Towards an Intelligent BIM Integrated Structural Design. In N. Dawood, F. Rahimian, S. Seyedzadeh, & M. Sheikhhoshkar (Eds.), *Proceedings of 20th International Conference on Construction Application of Virtual Reality* (pp. 272-279). Middlesbrough, UK: Teesside University Press.

- Harinarain, N. (2020). The Application of Virtual Reality in Construction Education: A South Africa Case Study. In N. Dawood, F. Rahimian, S. Seyedzadeh, & M. Sheikhhoshkar (Eds.), *Proceedings of 20th International Conference on Construction Application of Virtual Reality* (pp. 95-103). Middlesbrough, UK: Teesside University Press.
- Johansen, K. W., Nielsen, R. O., Schultz, C., & Teizer, J. (2020). Non-monotonic Reasoning for Automated Progress Analysis of Construction Operations. In N. Dawood, F. Rahimian, S. Seyedzadeh, & M. Sheikhhoshkar (Eds.), *Proceedings of 20th International Conference on Construction Application of Virtual Reality* (pp. 292-303). Middlesbrough, UK: Teesside University Press.
- Kumar, B. (2015). *A practical guide to adopting BIM in construction projects*. Dunbeath, UK: Whittles Publishing.
- L, R. A., A, V. G., & B, K. (2020). Improving Construction Risk Assessment via Integrating Building Information Modeling (BIM) with Virtual Reality (VR). In N. Dawood, F. Rahimian, S. Seyedzadeh, & M. Sheikhhoshkar (Eds.), *Proceedings of 20th International Conference on Construction Application of Virtual Reality* (pp. 64-72). Middlesbrough, UK: Teesside University Press.
- Latham, S. M. (1994). *Constructing the team: : Joint Review of Procurement and Contractual Arrangements in the United Kingdom Construction Industry*. London: HMSO.
- Lee, S., Kim, J., Cho, D., & Lee, J.-K. (2020). AR-based and User-Centered Approach to the On-site Design Decision Support for Building Remodel Projects. In N. Dawood, F. Rahimian, S. Seyedzadeh, & M. Sheikhhoshkar (Eds.), *Proceedings of 20th International Conference on Construction Application of Virtual Reality* (pp. 56-63). Middlesbrough, UK: Teesside University Press.
- Moshtaghian, F., Golabchi, M., & Noorzai, E. (2020). A framework to dynamic identification of project risks. *Smart and Sustainable Built Environment*. doi:10.1108/SASBE-09-2019-0123
- Murase, T., Sugihara, K., & Shen, Z. (2020). Automatic Generation of 3D Terrain Models for Debris Flow Simulation. In N. Dawood, F. Rahimian, S. Seyedzadeh, & M. Sheikhhoshkar (Eds.), *Proceedings of 20th International Conference on Construction Application of Virtual Reality* (pp. 304-315). Middlesbrough, UK: Teesside University Press.
- Nejad, R. H., Ghaffarianhoseini, A., & Ghaffarianhoseini, A. (2020). Automated Progress Monitoring via Fusion of 4D BIM and AI through Schedule Updating by Convolutional Networks and a Specialized Labelled Dataset for the Construction Components. In N. Dawood, F. Rahimian, S. Seyedzadeh, & M. Sheikhhoshkar (Eds.), *Proceedings of 20th International Conference on Construction Application of Virtual Reality* (pp. 196-208). Middlesbrough, UK: Teesside University Press.
- Newman, C., Edwards, D., Martek, I., Lai, J., Thwala, W. D., & Rillie, I. (2020). Industry 4.0 deployment in the construction industry: a bibliometric literature review and UK-based case study. *Smart and Sustainable Built Environment*. doi:10.1108/SASBE-02-2020-0016
- Nguyen, D. C., Shim, C. S., Nguyen, T. Q., Jin, R., & Jeon, C. H. (2020). Developing a Mixed-Reality Based Application for Bridge Inspection and Maintenance. In N. Dawood, F. Rahimian, S. Seyedzadeh, & M. Sheikhhoshkar (Eds.), *Proceedings of 20th International Conference on Construction Application of Virtual Reality* (pp. 31-43). Middlesbrough, UK: Teesside University Press.

- Ogunseiju, O., Akanmu, A., & Bairakt, D. (2020a). Holographic Learning Environment for Bridging the Technical Skill Gap of the Future Smart Construction Engineering Students. In N. Dawood, F. Rahimian, S. Seyedzadeh, & M. Sheikhhoshkar (Eds.), *Proceedings of 20th International Conference on Construction Application of Virtual Reality* (pp. 151-162). Middlesbrough, UK: Teesside University Press.
- Ogunseiju, O., Olayiwola, J., & Akanmu, A. (2020b). Digital Twin Driven Musculoskeletal Injury Prevention System. In N. Dawood, F. Rahimian, S. Seyedzadeh, & M. Sheikhhoshkar (Eds.), *Proceedings of 20th International Conference on Construction Application of Virtual Reality* (pp. 139-150). Middlesbrough, UK: Teesside University Press.
- Oliver, S. (2019). Communication and trust: rethinking the way construction industry professionals and software vendors utilise computer communication mediums. *Visualization in Engineering*, 7(1), 1. doi:10.1186/s40327-019-0068-y
- Oliver, S., Rahimian, F. P., Dawood, N., & Rodriguez, S. (2020). Converting Open Standard CAD Formats Into Decentralised Common Data Environment. In N. Dawood, F. Rahimian, S. Seyedzadeh, & M. Sheikhhoshkar (Eds.), *Proceedings of 20th International Conference on Construction Application of Virtual Reality* (pp. 174-183). Middlesbrough, UK: Teesside University Press.
- Pal, A., & Hsieh, S.-H. (2020). Vision-based Construction Site Monitoring: A Review from Construction Management Point of View. In N. Dawood, F. Rahimian, S. Seyedzadeh, & M. Sheikhhoshkar (Eds.), *Proceedings of 20th International Conference on Construction Application of Virtual Reality* (pp. 44-55). Middlesbrough, UK: Teesside University Press.
- Pidgeon, A., & Dawood, N. (2020). Conceptualizing 3D Model Development and Validation via the Integration of Speech Cognitive Processing. In N. Dawood, F. Rahimian, S. Seyedzadeh, & M. Sheikhhoshkar (Eds.), *Proceedings of 20th International Conference on Construction Application of Virtual Reality* (pp. 364-371). Middlesbrough, UK: Teesside University Press.
- Pilechiha, P., Mahdavinejad, M., Pour Rahimian, F., Carnemolla, P., & Seyedzadeh, S. (2020). Multi-objective optimisation framework for designing office windows: quality of view, daylight and energy efficiency. *Applied Energy*, 261, 114356. doi:<https://doi.org/10.1016/j.apenergy.2019.114356>
- Pour Rahimian, F., Chavdarova, V., Oliver, S., & Chamo, F. (2019). OpenBIM-Tango integrated virtual showroom for offsite manufactured production of self-build housing. *Automation in Construction*, 102, 1-16. doi:<https://doi.org/10.1016/j.autcon.2019.02.009>
- Pour Rahimian, F., Ibrahim, R., & Baharudin, M. N. (2008). *Using IT/ICT as a new medium toward implementation of interactive architectural communication cultures*. Paper presented at the Proceedings - International Symposium on Information Technology 2008, ITSIm.
- Pour Rahimian, F., Ibrahim, R., Rahmat, R. W. B. O. K., Abdullah, M. T. B., & Jaafar, M. S. B. H. (2011). Mediating cognitive transformation with VR 3D sketching during conceptual architectural design process. *Archnet-IJAR*, 5(1), 99-113.
- Pour Rahimian, F., Seyedzadeh, S., Oliver, S., Rodriguez, S., & Dawood, N. (2020). On-demand monitoring of construction projects through a game-like hybrid application of

BIM and machine learning. *Automation in Construction*, 110, 103012. doi:<https://doi.org/10.1016/j.autcon.2019.103012>

- Prabhu, G., & Abanda, H. (2020a). Developing an Intensional Definition Satisfying the Philosophy of Definitions to Appraise the Theory of BIM. In N. Dawood, F. Rahimian, S. Seyedzadeh, & M. Sheikhhoshkar (Eds.), *Proceedings of 20th International Conference on Construction Application of Virtual Reality* (pp. 228-241). Middlesbrough, UK: Teesside University Press.
- Prabhu, G., & Abanda, H. (2020b). Illuminating the Ideological Developments of BIM to Appraise the Terminology BIM. In N. Dawood, F. Rahimian, S. Seyedzadeh, & M. Sheikhhoshkar (Eds.), *Proceedings of 20th International Conference on Construction Application of Virtual Reality* (pp. 251-263). Middlesbrough, UK: Teesside University Press.
- Reyes-Veras, P. F., Renukappa, S., & Suresh, S. (2020). Awareness of Big Data concept in the Dominican Republic Construction Industry: An Empirical Study. In N. Dawood, F. Rahimian, S. Seyedzadeh, & M. Sheikhhoshkar (Eds.), *Proceedings of 20th International Conference on Construction Application of Virtual Reality* (pp. 336-349). Middlesbrough, UK: Teesside University Press.
- Rezakhani, M., & Kim, S.-A. (2020). Using Virtual Reality to Evaluate the Impact of Dispersion of Elements on Kinetic Façade. In N. Dawood, F. Rahimian, S. Seyedzadeh, & M. Sheikhhoshkar (Eds.), *Proceedings of 20th International Conference on Construction Application of Virtual Reality* (pp. 104-115). Middlesbrough, UK: Teesside University Press.
- Rhodes, C. (2019). *Construction industry: statistics and policy*. Retrieved from House of Commons Library: <http://researchbriefings.files.parliament.uk/documents/SN01432/SN01432.pdf>
- Sadeghineko, F., & Kumar, B. (2020). Facilitating Information Exchange for 3D Retrofit Models of Existing Assets Using Semantic Web Technologies. In N. Dawood, F. Rahimian, S. Seyedzadeh, & M. Sheikhhoshkar (Eds.), *Proceedings of 20th International Conference on Construction Application of Virtual Reality* (pp. 350-363). Middlesbrough, UK: Teesside University Press.
- Saovana, N., Yabuki, N., & Fukuda, T. (2020). An Image Feature Classification System for Piers Based on Semantic Segmentation with Deep Learning. In N. Dawood, F. Rahimian, S. Seyedzadeh, & M. Sheikhhoshkar (Eds.), *Proceedings of 20th International Conference on Construction Application of Virtual Reality* (pp. 325-335). Middlesbrough, UK: Teesside University Press.
- Sawhney, A., Riley, M., & Irizarry, J. (2020). *Construction 4.0: An innovation platform for the built environment*. London: Routledge.
- Seyedzadeh, S., Pour Rahimian, F., Rastogi, P., & Glesk, I. (2019). Tuning machine learning models for prediction of building energy loads. *Sustainable Cities and Society*, 47, 101484. doi:<https://doi.org/10.1016/j.scs.2019.101484>
- Shojaei, A., Rokooei, S., Carson, L., & Ford, G. (2020). Immersive Video Capture Technology for Construction Management Education. In N. Dawood, F. Rahimian, S. Seyedzadeh, & M. Sheikhhoshkar (Eds.), *Proceedings of 20th International Conference on Construction Application of Virtual Reality* (pp. 163-172). Middlesbrough, UK: Teesside University Press.

- Solberg, A., Hognestad, J. K., Golovina, O., & Teizer, J. (2020). Active Personalized Training of Construction Safety Using Run Time Data Collection in Virtual Reality. In N. Dawood, F. Rahimian, S. Seyedzadeh, & M. Sheikhhoshkar (Eds.), *Proceedings of 20th International Conference on Construction Application of Virtual Reality* (pp. 19-30). Middlesbrough, UK: Teesside University Press.
- Sugihara, K., Shen, Z., & Murase, T. (2020). Automatic Generation of 3D Building Models for BIM by Polygon Partitioning and Rectification. In N. Dawood, F. Rahimian, S. Seyedzadeh, & M. Sheikhhoshkar (Eds.), *Proceedings of 20th International Conference on Construction Application of Virtual Reality* (pp. 209-219). Middlesbrough, UK: Teesside University Press.
- Swallow, M., & Zulu, S. (2020). Virtual Reality in Construction Health and Safety Education: Students Experience through Video Elicitation - A Pilot Study. In N. Dawood, F. Rahimian, S. Seyedzadeh, & M. Sheikhhoshkar (Eds.), *Proceedings of 20th International Conference on Construction Application of Virtual Reality* (pp. 86-94). Middlesbrough, UK: Teesside University Press.
- Takahashi, R., Dan, H., & Yasumuro, Y. (2020). Image-based Verification and Mapping of Physical Barrier for Wheelchairs. In N. Dawood, F. Rahimian, S. Seyedzadeh, & M. Sheikhhoshkar (Eds.), *Proceedings of 20th International Conference on Construction Application of Virtual Reality* (pp. 372-380). Middlesbrough, UK: Teesside University Press.
- Tallgren, M. V., Roupé, M., & Johansson, M. (2020). Collaborative Scheduling with 4D Extended to Virtual Reality. In N. Dawood, F. Rahimian, S. Seyedzadeh, & M. Sheikhhoshkar (Eds.), *Proceedings of 20th International Conference on Construction Application of Virtual Reality* (pp. 73-85). Middlesbrough, UK: Teesside University Press.
- Xiong, R., & Tang, P. (2020). Visual Dust Emission Monitoring for Construction Activities. In N. Dawood, F. Rahimian, S. Seyedzadeh, & M. Sheikhhoshkar (Eds.), *Proceedings of 20th International Conference on Construction Application of Virtual Reality* (pp. 283-291). Middlesbrough, UK: Teesside University Press.
- Zhou, W., & Pushpala, P. (2020). Towards BIM-Based Assembly Capacity Analysis for Community Construction Site Planning and Simulation. In N. Dawood, F. Rahimian, S. Seyedzadeh, & M. Sheikhhoshkar (Eds.), *Proceedings of 20th International Conference on Construction Application of Virtual Reality* (pp. 264-271). Middlesbrough, UK: Teesside University Press.

Part2. AR & VR, Serious Games & Wearables

SUPERIMPOSING BUILDING INFORMATION MODELS IN AUGMENTED REALITY

Vishak Dudhee & Vladimir Vukovic

School of Computing, Engineering and Digital Technologies, Teesside University, Middlesbrough, UK

ABSTRACT: *Augmented Reality (AR) can enhance Building Information Modelling (BIM) by allowing architecture, engineering, and construction (AEC) professionals to visualise and refine building models. The possibility of integrating BIM model in AR environment provides an effective solution to all phases of a building's lifecycle. To visualise digital information in the actual physical environment, BIM models are superimposed to the structure. The techniques used to superimpose the BIM models are either based on reference markers or QR codes, which are occasionally inaccurate. This paper reviews and analyses the BIM model superimposing techniques in AR. To describe and discuss different methods, a BIM model of an office room was generated in Revit and superimposed to the actual physical space using two different AR devices and four different AR applications. From the results obtained, it can be concluded that presented superimposing methods allow for overlaying of digital information, but model positioning can be slightly inaccurate depending on the superimposing method used and AR device. Any inaccuracy while positioning the BIM model reference markers or QR code can lead to inaccurate superimposing of the model. The recommended process and method for superimposing BIM in AR environment is documented.*

KEYWORDS: *Building Information Modelling (BIM), Augmented Reality (AR) environment, Superimposing*

1. INTRODUCTION

During construction, “omission errors” are often committed due to the lack of information available on hand (Love et al., 2009). Team members do not consistently and enthusiastically spend time and effort to get access to the required information, which is stored remotely or distantly, requiring them to be physically away from the task that they are performing. Wearing a head-mounted AR device that includes all of the building information in the form of a BIM model can mitigate this issue as the worker would not have to be detached from their task and the information can be made directly relevant to the task. The integration of BIM and AR can also enhance the visualisation of different phases of a project lifecycle and eventually improve the final product (Wang et al., 2014). The use of a 3D BIM model in architecture, engineering, and construction has already shown its numerous benefits. It allows designers to virtually test the proposed alternative designs and identify any possible problems at an early stage of the construction process. Using AR, BIM information can be visualised in real time and in the actual physical setting, particularly during the construction, maintenance, and operational stages of a building (Yan, Culp & Graf, 2011). This can improve decision making, eventually allowing tasks to be efficiently and effectively executed.

The construction process consists of a large number of tasks and subtasks classified into three main categories: input, output, and processing (Bernold & Abourizk, 2010). The input mainly consists of material, labour and time; the output mainly includes waste, cost, quality and schedule overrun; and the processing consists of preparation, transformation, monitoring and cleaning. Such construction processes can be reclassified and connected in terms of product, process, and resources.

To fully benefit from the integration of BIM and AR, the 3D BIM model of the building needs to be precisely superimposed to the actual physical environment in AR. At the moment, the superimposing techniques that are used to overlay the 3D BIM model on the actual physical environment mainly use reference points (Mahmood, Han, & Lee, 2020). The accuracy of the reference point techniques depends on various factors such as the user's knowledge of the pre-set reference point and the ability to set the reference points at the same location in the physical AR environment. This paper describes and analyses the various superimposing techniques that are being used in current BIM-AR applications. The limitations of those superimposing techniques are discussed, and a new automated superimposing approach is proposed.

2. TRACKING AND IMPOSING

2.1 Tracking

Tracking is a technique used by extended reality (XR) equipment such as head-mounted displays (HMD) to determine the position of an object in the virtual or augmented real-world environment (Sherman & Craig, 2019; Pearlman et al., 2019). Outside-in and inside-out tracking can be distinguished. The difference between outside-in tracking and inside-out tracking lies in the location of the cameras and sensors that define the object's position in the space (Ribo, Pinz, & Fuhrmann, 2001). For inside-out tracking, the camera and sensors are located on the HMD, whereas for outside-in tracking, a stationary tracking device is mounted to a fixed location in the scene. While using the inside-out tracking method, the camera incorporated in the HMD determines the changes of the equipment's position in relation to the external environment. To create an illusion of walking through the virtual environment in real-time, sensors adjust the user's spatial position when the headset moves (Keil, Edler, & Dickmann, 2019). Such tracking method can be used both for marker-based tracking, where markers are used as reference points, and markerless inside-out tracking, which uses natural features to determine its positions. Markerless inside-out tracking is a technique that identifies specific shapes and images that are already present in the physical environment to calculate and determine the position and orientation of an AR device in physical space. Such positional tracking system uses data from accelerometers and gyroscopes to enhance precision. In marker-based tracking, fiducial markers, positional markers, or infrared markers are used to allow the tracking system to easily detect and position the HMD in the specific environment (Borrego et al., 2016). The fiducial markers are in the form of primitive shapes such as points, circles, or squares. Quick Response (QR) codes are commonly used positional markers placed in the physical environment as reference points. Infra-red (IR) markers and cameras sensitive to different types of light can also be used. The marker-based tracking is effective only if the markers are within the field of view of the HMD and can be clearly detected.

2.2 Model Imposing

To provide a realistic and accurate AR experience, digital information must be aligned with the elements of the real physical space (Montero et al., 2019). Digital models can be superimposed in an AR space in two ways: (1) through tapping the digital model into the physical environment's surface, or (2) by snapping the model to a QR code, which physically represents the origin of the model, or a reference point (Hashimoto, 2020). Measuring placement of the QR code can facilitate accurate positioning of the model in the physical environment. Alternatively, model placement and adjustment in the AR environment is possible using the X, Y, and Z plane if high accuracy is not required. Snapping digital objects in an augmented reality setting is inherently more challenging than snapping in a virtual reality because of physical constraints such as sensor noise, environmental complexity, and hardware limitations (Nuernberger et al., 2016). In an AR environment, the likelihood of extracting the wrong constraints is higher and can negatively affect the snapping performance. An ideal AR system creates the illusion that the real and virtual components coexist in the space (Montero et al., 2019). However, most AR applications require much work before they will be capable of creating this impression. Although AR technology has advanced, most software applications still cannot imitate the experience of virtual objects being part of the real physical setting.

3. METHODS

To analyse the different superimposing techniques used to superimpose a 3D BIM model in AR environment and evaluate the methods' effectiveness, a BIM model of an office room located in the Phoenix Building at Teesside University's Middlesbrough campus was created. The two pieces of AR equipment used in this experimentation were Microsoft HoloLens 1 Development Edition, which is the first mixed reality head-mounted headset developed and manufactured by Microsoft Corporation, and Daqri Smart Glasses, which was created for use in a variety of areas, including technical visualisation with BIM. The Microsoft HoloLens runs the Windows mixed reality platform in the Windows 10 operating system and can run third party applications. The Daqri Smart Glasses consists of a wired control box that provides the required computing power and the device operates on an internally-built Visual Operating System (VOS). Testing examined four different BIM-AR applications: 3D Viewer Beta (Microsoft, 2016), BIM Holoview (Revit-Holoview, 2017), HoloLive (VisualLive, 2018) and Model-BIM (Daqri, 2018). The Microsoft HoloLens has a wider range of software available that allow visualisation of digital models in AR compared to Daqri which is limited to its inbuilt application Model-BIM. The applications chosen for Microsoft HoloLens were based on compatibility with BIM models and availability.

3.1 BIM 3D Model

Room P1.09 is an office on the first floor of Phoenix Building. The room was selected to perform the test being easily accessible and available. A model of the room was generated in Revit (Autodesk, 2019) version 2019.2 based on available information and observation. Available 3D CAD model and 2D plans allowed positioning of the MEP components in the room model. Being an office, the Room consisted of electrical and mechanical (heating, ventilation, and air-conditioning) system components. As the exact designs and information on some of the room elements, such as the doors, windows, and electrical trays were not available, similar components' designs were used keeping the size and properties as close as possible to reality.

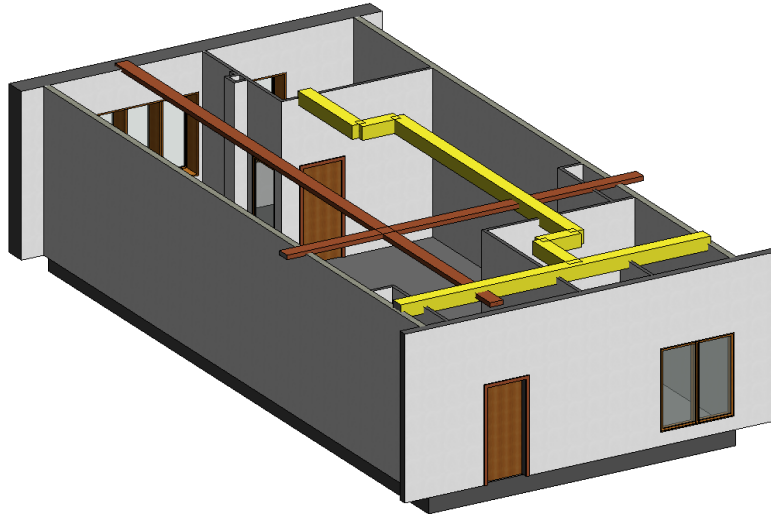


Fig. 1: Created BIM model in Revit file format (RVT)

The room's BIM model is shown in Fig. 1. Due to the limited textures available as default in Revit, assigning the desired colours to the different components was challenging. The heating system of the room is highlighted in yellow, the electrical cable trays in brown, the walls in white and the doors and windows in a darker brown wooden texture in order to differentiate different components in the room.

3.2 Superimposing Model

The superimposing test used the 3D viewer software 3D Viewer Beta, BIM Holoview and HoloLive on Microsoft HoloLens and Model-BIM on DAQRI Smart Glasses. The 3D viewers descaled the model to a reasonable size fitting the HoloLens display so that positioning, moving, and rotating the model were easier. To superimpose the model into the actual building, the model was first placed at a correct position and then scaled accordingly. After an inbuilt room scan, the software added a grid on the bottom level to guide and increase the precision while positioning the model on the floor or table. The software scaled the model in terms of percentages rather than using ratios. Therefore, the scaling process relied on trial and error, personal judgement, and consideration of reference points such as walls, roof and other various components. As the model scaled up, minor adjustments using rotation and moving options were frequently made to secure the model in the correct position. The scaling, rotating, and moving process repeated until the model was superimposed on the actual building.

The BIM Holoview, HoloLive and Model-BIM were designed with the BIM model in mind. The Holoview and HoloLive software included a variety of options for superimposing the BIM model in a physical environment. Before sending the model to the AR equipment, reference points were added to specific locations in the model. Two or more reference points were required to position the model in the AR environment. The same reference points were then identified and selected in the physical environment to fit the model to the right place and orientation. In case of any misalignment, the application provided various options to adjust the model to the physical environment. Daqri has a set procedure of accessing and visualising a BIM model in AR which includes the use of BIM 360 Docs and Daqri BIM 360 Viewer. Model-BIM uses QR codes and landmarks set on the model and on the actual physical environment. Using this system, once the equipment scans the QR code or landmark, the model is automatically imposed into the environment.

3.3 Analysis and evaluation

Validation included visual inspection of the superimposed model in the actual office room. The model was first validated by ensuring the reference points were at the predicted locations and that the model's layout was perfectly matching the physical building's layout. Then, the alignments of the model's electrical and mechanical components were checked in comparison to the actual room lighting, ventilation openings and plumbing.

4. RESULTS

The model superimposed in 3D viewer Beta, BIM Holoview, HoloLive and DAQRI's Model-BIM is illustrated in Fig. 2, 3, 4 and 5, respectively. The models were imposed on the actual physical room using different techniques described in Section 3.



Fig. 2: Room P1.09 lighting fixture superimposed on 3D Viewer Beta

Using the 3D Viewer Beta AR software, the model was superimposed by trial and error. The superimposing process itself was time consuming and took several attempts before it was closely aligned to the physical room. The model needed to be scaled to right size, rotated to the correct position and then aligned to the room using reference points set on the model. During the scaling and aligning process, often the model maintained its original placement and created large misalignments. Such issues would result in restarting the entire superimposing process.



Fig 3: Room P1.09 lighting fixture superimposed on BIM Holoview

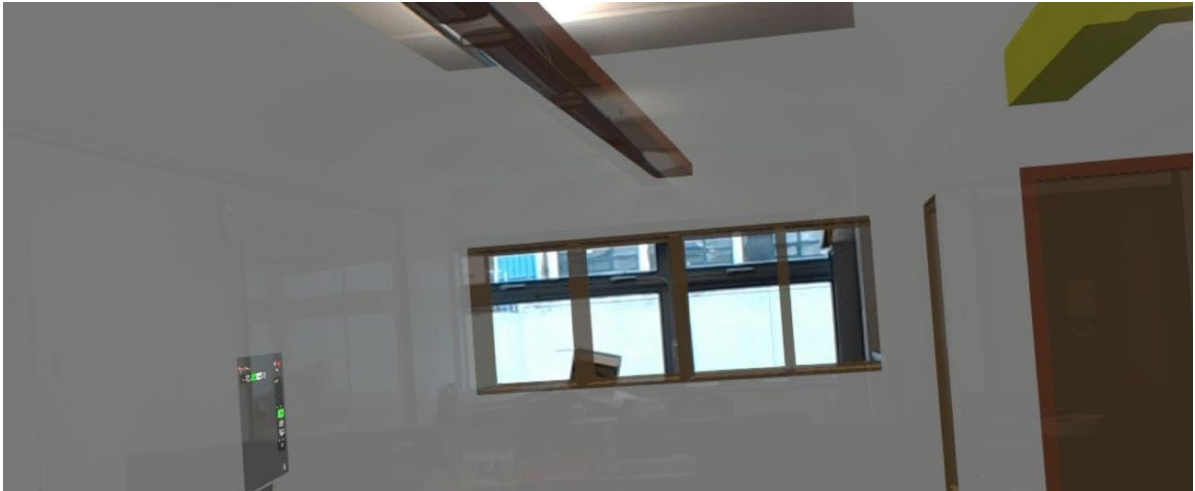


Fig. 4: Room P1.09 section superimposed on HoloLive

HoloLive allowed the option to use either reference points or QR codes to superimpose the model into the physical environment, whereas in BIM Holoview only the reference point method was available. The reference point system available on HoloLive and BIM Holoview was developed for superimposing specifically BIM models in AR. Therefore, such a system was more accurate than 3D Viewer Beta and relatively easier to use and align the model in AR. Using the reference point system, the BIM model is set in the correct orientation. Model alignment can be finetuned by moving the model but does not require rotation.

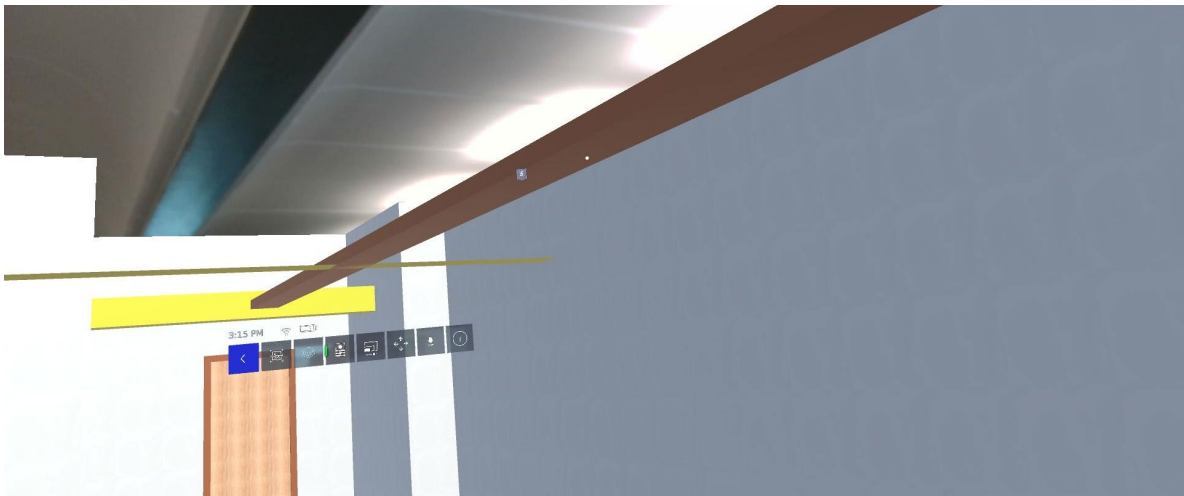


Fig. 5: Room P1.09 cable trays and ductwork superimposed on DAQRI - Model BIM

Daqri Smart Glasses and Model BIM also take into consideration the integration of BIM in AR. Therefore, the superimposing procedure set by Daqri and the available options allow more accurate model alignment to the physical room compared to the other tested software. Using the QR code, the model can be directly accessed and, using the landmark, aligned to the room. After imposing the model, the software allows refining the alignment by moving the model along the three-dimensional Cartesian coordinate axes with a high level of precision.

In terms of the time taken to superimpose the model in the actual physical room, attempting through trial and error took around 10-20 minutes, using the reference points it took between 3-5 mins and using the landmark method it took around 2 mins. The trial and error method was the slowest with the landmark positioning system being around 5-10 times faster. The use of reference points was relatively faster than the trial and error method but slightly slower than the landmark positioning system.

5. DISCUSSION

5.1 Model Superimposing

Models which consist of reference points or landmarks can be superimposed using those reference points. However, models without reference points needed to be superimposed manually by trial and error. There is a high probability when using this technique that the model will take significant time and effort to even come close to superimposing the model accurately. This technique is not always feasible and can introduce alignment errors of the model in the design. The rotation and movement of the model in the AR environment is done by using the scaling system rather than a ratio system, creating inaccuracies.

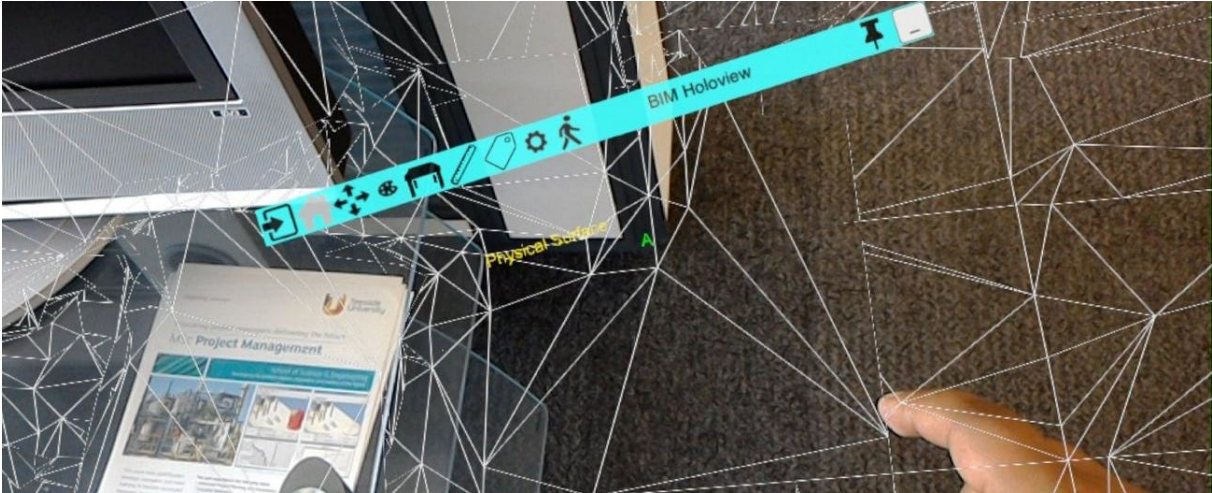


Fig 6: Microsoft HoloLens Mesh Density

Mesheres are used to scan and place the model in real surroundings. Microsoft HoloLens had a default mesh density as illustrated in Fig. 6 which could not be reprogrammed in the device. Corners, edges, and other small elements of a building could not be precisely scanned. Therefore, the use of corners and building edges as reference points to superimpose a building model could sometimes cause misalignment. A difference of a millimetre at a reference point can cause the other end of the model to be drastically misaligned as illustrated in Fig. 7.

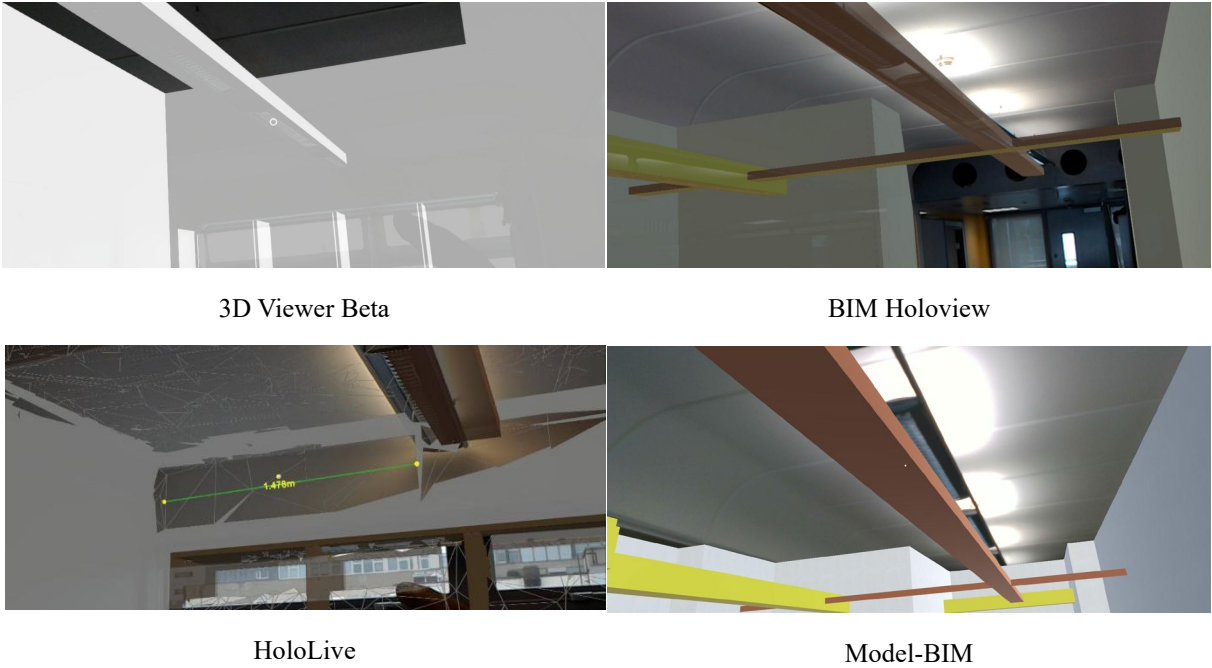


Fig. 7: Room P1.09 superimposed comparison

5.2 Recommended process

Inaccuracies while superimposing BIM models in AR can emerge due to various factors such as the tracking technology, mesh density or the technique and process used. In this experiment, several approaches were compared with respect to alignment accuracy while superimposing the P1.09 office room model. Some of the practices which improved the alignment and accuracy were (1) Avoiding the positioning of reference markers on corners and edges and, instead, positioning the reference markers on a horizontal or vertical open flat surface that has been measured and marked both in the model and in physical space. Scanning elements such as corners and edges can be imprecise compared to open flat surfaces due to the tracking technology and mesh density; therefore, using an open flat surface, the reference points can be accurately placed in the AR environment. (2) While using a fiducial marker, the use of circles or ring shapes can improve the alignment process and act as guide while finetuning the model position.

6. CONCLUSION

Although the model was superimposed to the actual room using pre-set reference points or landmarks, there were some slight misalignments. AR technology is still emerging and rapidly developing. The AR devices used in this study represent the first generation of head-mounted headsets; therefore, their uses are still limited, and the positioning techniques have some inaccuracies. New techniques that do not require manual adjustments should be developed to improve the accuracy of superimposing models into buildings. At this stage, the functions of the AR devices and commercially available BIM-AR applications are limited and still under development. The current scanning technology is insufficiently adequate in terms of efficiency and accuracy. By following the recommended processes, the inaccuracies and the time needed for superimposing BIM models in AR can be reduced by 50%, but the invention of more robust scanning technology may improve the imposing and superimposing accuracy of BIM models in AR.

7. REFERENCES

- Autodesk (2019). Revit (2019.2) [Computer Software], Autodesk Inc. Retrieved 31 January 2019, from <https://www.autodesk.co.uk/products/revit/>.
- Bernold, L. E., & Abourizk, S. M. (2010). *Managing performance in construction*. Hoboken, NJ [u.a.]: Wiley.
- Borrego, A., Latorre, J., Llorens, R., Alcañiz, M., & Noé, E. (2016). Feasibility of a walking virtual reality system for rehabilitation: Objective and subjective parameters. *Journal of Neuroengineering and Rehabilitation*, 13(1), 68. doi:10.1186/s12984-016-0174-1
- Daqri. (2018). Model-BIM [AR App]. Retrieved 6 August 2019.
- Hashimoto, J. (2020). *Capturing tacit knowledge through smart device augmented reality (SDAR)* (Doctoral Thesis, University of Hawaii, Manoa, Hawaii). Retrieved from <https://scholarspace.manoa.hawaii.edu/>
- Keil, J., Edler, D., & Dickmann, F. (2019). Preparing the HoloLens for user studies: An augmented reality interface for the spatial adjustment of holographic objects in 3D indoor environments. *KN - Journal of Cartography and Geographic Information*, 69(3), 205-215. doi:10.1007/s42489-019-00025-z
- Love, P. E. D., Edwards, D. J., Irani, Z., & Walker, D. H. T. (2009). Project pathogens: The anatomy of omission errors in construction and resource engineering project. *IEEE Transactions on Engineering Management*, 56(3), 425-435. doi:10.1109/TEM.2008.927774
- Mahmood, B., Han, S., & Lee, D. (2020). BIM-based registration and localization of 3D point clouds of indoor scenes using geometric features for augmented reality. *Remote Sensing (Basel, Switzerland)*, 12(14), 2302. doi:10.3390/rs12142302
- Microsoft (2016). 3D viewer beta [HoloLens], Microsoft Corporation. Retrieved 12 February 2019, from <https://www.microsoft.com/en-us/p/3d-viewer-beta/9nblggh5pm4z?activetab=pivot:overviewtab>.
- Montero, A., Montero, A., Zarraonandia, T., Zarraonandia, T., Diaz, P., Diaz, P., . . . Aedo, I. (2019). Designing and implementing interactive and realistic augmented reality experiences. *Universal Access in the Information Society*, 18(1), 49-61. doi:10.1007/s10209-017-0584-2

- Nuernberger, B., Ofek, E., Benko, H., & Wilson, A. SnapToReality: Aligning augmented reality to the real world. 1233-1244. doi:10.1145/2858036.2858250
- Pearlman, K., Bonneau, R., Magnano, M., & Newman, R. (2019). The XRSI definitions of extended reality (XR). XR Safety Initiative.
- Revit-Holoview (2017). BIM holoview [HoloLens], Revit-Holoview Ltd. Retrieved 29 July 2019, from <http://www.bimholoview.com/Features>.
- Ribo, M., Pinz, A., & Fuhrmann, A. L. A new optical tracking system for virtual and augmented reality applications., 3 1932-1936 vol.3. doi:10.1109/IMTC.2001.929537
- Sherman, W. R., & Craig, A. B. (2019). Understanding virtual reality (Second edition ed.). Cambridge, MA: MK, Morgan Kaufmann Publishers.
- VisualLive (2018). HoloLive [HoloLens], Visual Live 3D LLC. Retrieved 15 July 2019, from <https://visuallive.com/hololive-ar-for-construction/>.
- Wang, J., Wang, X., Shou, W., & Xu, B. (2014). Integrating BIM and augmented reality for interactive architectural visualisation. Construction Innovation, 14(4), 453-476. doi:10.1108/CI-03-2014-0019
- Yan, W., Culp, C., & Graf, R. (2011). Integrating BIM and gaming for real-time interactive architectural visualization. Automation in Construction, 20(4), 446-458. doi:10.1016/j.autcon.2010.11.013

ACTIVE PERSONALIZED TRAINING OF CONSTRUCTION SAFETY USING RUN TIME DATA COLLECTION IN VIRTUAL REALITY

Alex Solberg, Jens K. Hognestad, Olga Golovina, Jochen Teizer
Aarhus University

ABSTRACT: *Accidents resulting from poorly planned or set up work environments are a major concern within the construction industry. Even in a country like Denmark, which is known for its strict compliance with occupational safety, health and well-being, few to any of the educational concepts on construction safety and health education have focused on the use of advanced technologies that engage workers more actively in learning. While traditional education and training of personnel offer well known approaches for establishing safe work practices, Serious Games in Virtual Reality (VR) are increasingly being used as a complementary approach for active learning experiences. Their designs yet have to take full advantage of how a user can manipulate and interact with virtual imagery generated by the computer. In addition, little understanding exists in generating and analyzing the inherent synthetic data that can be collected about users in VR. This research presents a framework for the generation and automated assessment of such data in VR. The proposed approach is tested and evaluated in a virtual work environment consisting of, next to a user performing a realistic work task, multiple hazards that are consistent within today's construction sites. While virtual sensors augment the immersion of the participant in the virtual scene, run time data analysis provides opportunities for rapid personalized feedback. Encouraging results on the experiences of the participants are presented and discussed based on real needs in the Danish construction industry. An outlook presents future avenues towards enhancing existing learning methods.*

KEYWORDS: *Augmented virtual reality; construction safety, health, and well-being; run time synthetic data mining; personalized feedback and learning environments; education and training; user experience.*

1. INTRODUCTION

The construction industry in many countries tends to have more injuries and fatal accidents than other industries (Park and Kim, 2013; Teizer et al., 2013; Li et al., 2012; Li et al., 2018). This negative track record can be explained by the high-risk activities that are involved in construction, for example, work at elevation and in complex, often dynamic work environments. Although many initiatives have been taken to prevent incidents from occurring, the number of injuries have stagnated (Hu et al., 2011). In addition to being one of the most hazardous industry sectors to work for, the construction industry is known to be conservative and slow in innovation, incl. adopting of emerging technologies (von Heyl and Teizer, 2017; Cheng et al. 2010). Low profit margins and the uniqueness of every construction project have made it difficult to establish a general framework applicable. Recently, the construction industry has shifted towards a digital transition. For example, Building Information Modeling (BIM), plays an active role in driving change to current information management processes and data visualization and communication methods. BIM per se provides various potential benefits like clash detection, cost and time estimation. It gives a user an informed image of a physical space of the intended construction. Applied to safety and health, previously not possible design and planning tools can be made available to prevent injuries and fatalities in construction (Melzner et al., 2013, Getuli et al., 2020). Most recently, with the emerging of ever more powerful technologies for Virtual Reality (VR), it has become possible to experience and practice hazardous situations without the risk of exposing an individual to physical harm (Fang et al., 2010). As Sacks et al. (2013) stated, VR allows advanced safety and health training where mistakes do not equal injuries.

In another relevant study, an analysis of construction accident statistics revealed: falls from height; being struck by a moving vehicle; being struck by a moving/falling object; or getting trapped by something overturning/collapsing, are the primary causes of construction workplace deaths (Zhou et al., 2012). Few, if any, recent research publication has reported on the construction safety performance in Nordic countries (incl. Denmark, Iceland, Finland, Norway, and Sweden) (Figure 1). However, the focus areas differ. Since 2015 “falls to a lower level” were the most common accident cause in Denmark. “Hit by an object”, for example, by heavy machinery not being secured properly or operated correctly, and “fall on the same level”, for example, slips and trips, came in second and third (Dansk Arbejdsgiverforening, 2019). In 2018, Denmark faced 1.2 fatalities per 100,000 workers in the construction industry (Danmarks Statistik, 2020). Compared to Norway, the occupational death rate was 1.7 per 100,000 workers (SSB, 2019), whereas the Swedish construction industry faced 3.5 deaths per 100,000 workers in the same year (Statistikdatabasen, 2019). In Finland, 3.2 fatalities occurred per 100,000 workers

(Statista, 2019). In Iceland, only few employees are working in the construction industry. This explains that few fatalities have greater impact on the fatality-rate. In addition, as seen elsewhere in the world, it is difficult in most countries to obtain statistical data on safety records that allows a fair comparison (Eisenberg, 2010). The Icelandic data, for example, was retrieved from reports written in Icelandic only and its industry specific data was obtained by interpreting descriptions in accident reports. Note: The Icelandic data from 2018 is not yet published and therefore not included (Vinnueftirlitid, 2020).

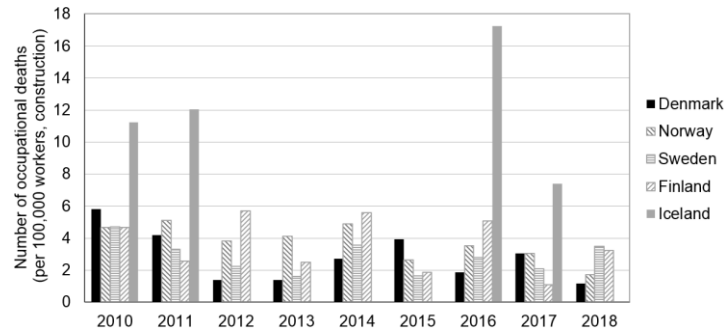


Fig. 1: Number of occupational deaths (per 100,000 workers) in Nordic countries.

As shown by the numbers, the construction industry continues to be one of the industries providing the most hazardous workplaces in the world (and in Denmark). This indicates that there is still a large need for better safety at all levels in the hierarchy of controls (Teizer, 2016), incl. education and training. For reasons explained earlier, this paper focuses on some of the most hazardous workplace situations (“fall to a lower level” and “fall on the same level”). The next sections explain the research motivation, the development of a Serious Game in VR and its implementation, and the results of a preliminary evaluation in detail. A discussion and outlook conclude this paper.

2. BACKGROUND

VR as a method for construction safety education and training has received exponential interest among researchers. Some of the reasons for this are VR’s ability to present a hazardous training environment “safely” while engaging the cognitive capability of the participants. The following describes the foundations of the Virtual Reality Continuum in the context of construction safety. Thereafter, a literature review on the existing knowledge within this field is presented.

2.1 Virtual Reality Continuum

As explained by Looser et al. (2004), the Reality-Virtuality Continuum consists of Reality (R), Augmented Reality (AR), Augmented Virtuality (AV) and Virtual Reality (VR), where Mixed Reality (MR) is the umbrella term for AR and AV. The continuum is a continuous scale between completely real and completely virtual (Figure 2). In context of this research, VR, for example, allows a user to be fully immersed in a virtual world by using computer software (gaming) technology and a Head Mount Display (HMD) (Rosenberg, 1993). The environment often is a virtual representation of the physical work-space created by computer-generated images. VR typically integrates audio and audiovisual responses (Steuer, 1992), but may also consent other types of physical components and force feedback through haptic technology, then called AV (Chi et al., 2013). VR or AV both have the opportunity to increase the perceived realism and evolve the degree of synthetic data collection and analysis, useable, for example, in construction safety and health education and training (Bükrü et al. 2020a; Bükrü et al. 2020b).

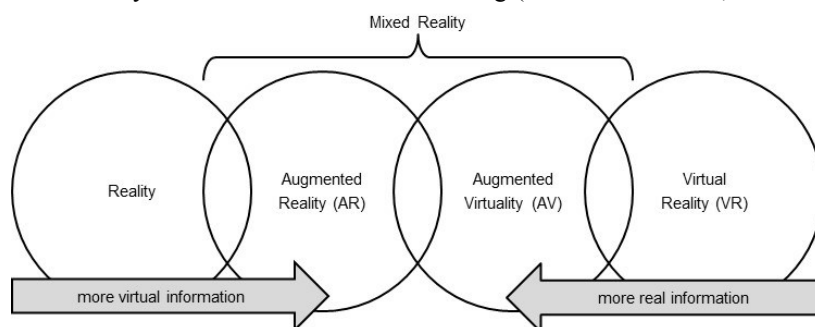


Fig. 2: Virtual Reality Continuum (Looser et al., 2004)

2.2 Active Learning

Two prevalent approaches are commonly used in an educational setting: The practical approach and the theoretical approach. Practical knowledge is acquired through hands-on experience and learning-by-doing. Theoretical knowledge is, on the other hand, obtained by reading theory or by reasoning (van de Ven and Johnson, 2006). Preparing students for the real world, on the other hand, can be a difficult task for educators. It is difficult to teach theory-based knowledge and assure that students are able to transfer that knowledge to real-life situations (van de Ven and Johnson, 2006).

The proposed learning approach makes theory more practical as it includes realistic scenarios from real-life activities in an active learning environment. A way of doing so is to merge the hands-on approach of the active learning principles with educational technology. In education and training matters. Educational Technology is trending. Januszewski and Molenda (2013) defines Educational Technology as "the study and ethical practice of facilitating learning and improving performance by creating, using and managing appropriate technological processes and resources". Educational Technology, therefore, is enhancing the teach-learn environment and facilitates flexible, open and distance learning (Januszewski and Molenda, 2013). The technology used for teaching can be audio-video, images and text to new and more advanced aspects like computer-, mobile- and virtual-based learning (de Vries, 2018).

Although technologies are introduced to enhance teaching and learning, it is essential to use them only where they provide value. Technology should be convenient and user friendly. However, the increasing complexity of technology makes the process of both learning and teaching difficult. In order to successfully implement Educational Technology in teaching, it requires the educator to distance oneself from conventional teaching and become acquainted with the technology and the new role as a link between technology and learners (Stošić, 2015).

The goal for active learning is to have a documented beneficial effect, compared to traditional training which has been proven to be less effective. As Burke et al. (2006) have shown in a study from 1971 to 2003, the learning outcomes of active safety training for users is on average three times more effective. Settles (2011) describes active learning to any instructional methodology engaging the participants in the learning process. Active learning requires the participant to actively engage in the process by using knowledge and intuition for problem-solving. Researchers have previously argued that it is "too complicated to design educational models that are more at odds with current research on human cognition" compared to traditional training (Horswill et al., 2008). The cognitive processes, referred to, include decision making, reaction time, attention, contrast sensitivity and visual pursuit of dangerous situations (Horswill et al., 2008). The ability of a worker to identify hazardous situations and environments is dependent on the individual worker's intuition and experience. New technology has made it possible to change human cognition by simulating a physical workspace in a safe training environment using serious game technology. Serious game technology is referred to as an educational game not only meant for entertainment. In the pyramid of learning effectiveness originally proposed by Dale (1954), the hierarchy of trainee effectiveness indicates active learning as much more beneficial than conventional approaches (Figure 3, left image).

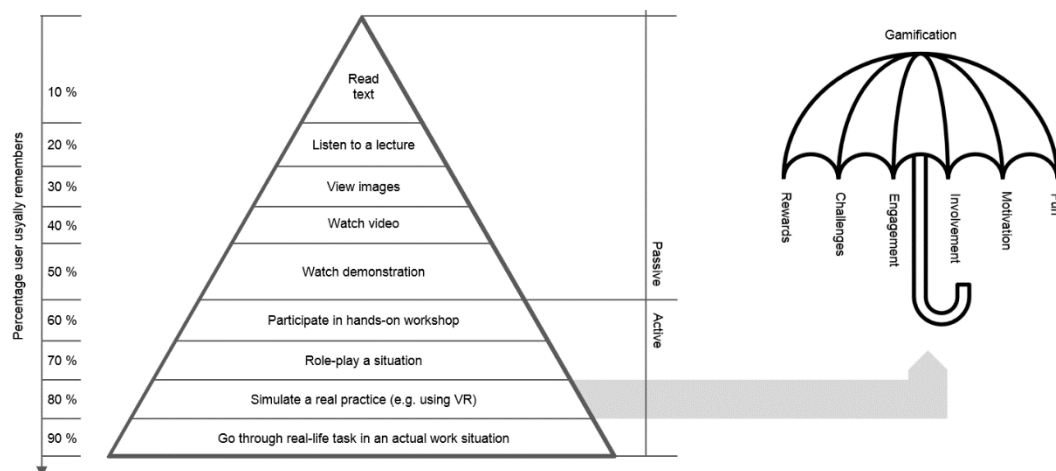


Fig. 3: Cone of learning experience and umbrella view of gamification

2.3 Gamification

Video games have increased in popularity since the late 1970s and early 1980s and are now the largest player in the entertainment market in economic terms (Dominguez et al., 2013). In recent years, educators have looked toward the gaming industry. Video games set goals for the player and an active learning process and development is required to reach these goals. Educators have now discovered how these advantages can be used to combine learning in almost every field with the challenges, goals and perceived amusement from gaming (Dominguez et al., 2013; Muntean, 2011; Su and Cheng, 2015). Gamification in learning using VR represents practical and theoretical learning combined where the sense of sight, sound and even touch are activated. A study concludes that gamification increases the engagement in learning as it gets more interesting and fun to learn by rewarding, involving and challenging the users (Figure 3, right image) (Muntean, 2011).

2.4 State-of-the-Art in Construction Safety Education and Training

While construction workers play a pivotal role in assuring safe construction activities, safe construction operations require efforts by all participating stakeholders in a project. Hazard awareness, recognition, and rectification of workers are some of the paramount components of distinguishing safe from unsafe work practices (Holt, 2001). As part of this effort, effective safety education and training are keys in preventing construction accidents (Guo et al., 2012; Lu and Davis, 2016; Park and Kim, 2013). Too often, hazards are learned by self-experiencing the consequences of one's own wrongdoing. A large, untapped potential exists in safely and actively experiencing hazards in a VR-enabled work environment (Lu and Davis, 2016).

A comprehensive construction safety study on the relative effectiveness of worker safety and health training methods carried out by Burke et al. (2006). They highlighted that active over conventional safety training (e.g., frontal lectures, reading text, showing videos and pictures, demonstrations in a classroom environment) showed 3 times higher effectiveness in behavioral change. Research on MR and VR assured further benefits of user-centered and performance-enhancing approaches (Dunston and Wang, 2011; Guo et al., 2012; Cheng et al., 2013; Park and Kim, 2013; Kassem et al. 2017).

A selected literature search on the expressions 'virtual reality' in the application of 'construction safety education and training' among scientific construction journals between 1996-2019 (e.g., The International Association for Automation and Robotics in Construction (ISARC) (number of papers found: 10), Automation in Construction (10), Institute of Electrical and Electronics Engineers (IEEE) (9), Computing in Civil Engineering (4), Advanced Engineering Informatics (2), Safety Science (2), Accident Analysis and Prevention (2), Association of Researchers in Construction Management (ARCOM) (2), European Group for Intelligent Computing in Engineering (EG-ICE) (1), and others (60), resulted in a portfolio of 102 papers (Figure 2, left image). These publications were screened for the evaluation methods applied in the respective studies. Among them were: survey/questionnaires, interviews, manual assessments, and observations by third party/researchers (Figure 2, right image). Most commonly were used 'pre- and/or exit survey', 'real-time or post data collection and analysis', 'pre- and/or exit interviews' and 'observation'. In 41% of the papers, more than one method was used and in 26% of the papers no specific evaluation method was used. Our search over the past 15 years found an increased interest in using VR technology for construction safety education and training.

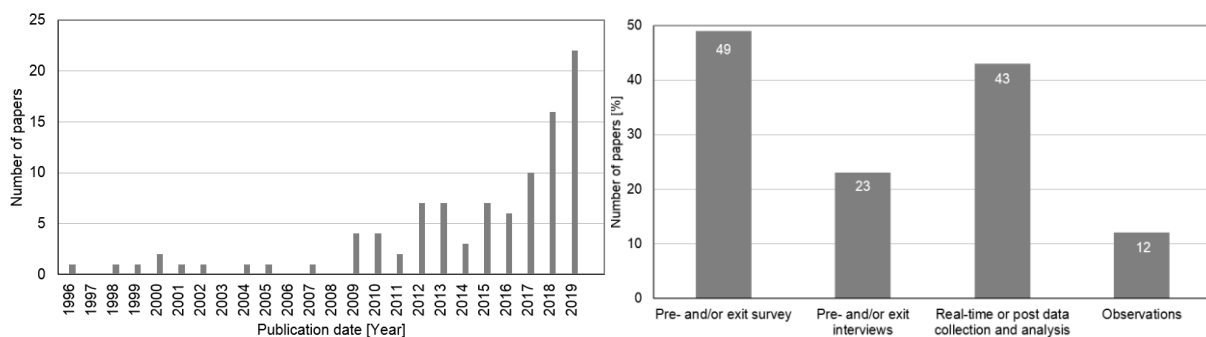


Fig. 4: Evaluation methods used in research (left image) and number of publications on the topics VR for construction safety (right image)

Therefore this research seeks to examine VR’s ability to provide active personalized feedback in construction safety education and training by using run time synthetic (VR-enabled) data recording and analysis. The following preliminary research questions were pursued:

- Does VR has the potential to become a viable tool in construction safety education and training?
- How can VR provide active personalized feedback?

3. METHODOLOGY

Many approaches can be taken in terms of deciding and using different VR hardware and software. In the following, the equipment and software used for this research will briefly be described. Thereafter, the evaluation methodology to evaluate the users’ safety and effectivity performance in the implementation will be presented.

3.1 Hardware

Various VR hardware solutions exist where some of the most popular ones include the Oculus Quest, Sony PlayStation VR, HTC Vive and Valve Index. In this research, HTC Vive was chosen as VR-hardware. The implementation includes 2 controllers, 3 trackers, 2 base stations and 1 Head-Mounted Display (HMD) (Figure 5). The HTC Vive provides positional tracking (6 Degree of Freedom, DoF) which not only allows the user to observe a scene in VR, but also to track the user’s head position and orientation within a few meters of walking distance (in real life) from the center of a virtual room (Borrego et al., 2018). While this can be a limitation, setting a room-scale experience provides an authentic virtual experience to test VR-based safety education and training conditions.

One tracker each was used to track real objects in VR (e.g., safety shoes and helmet), hereby, augmenting virtuality (AV) by inserting touchable objects in the VR scene. The trackers now allow detection of collisions, for example, one safety shoe stepping in a floor opening (in reality: as small elevation change; and in the VR scene: modeled as a 3D object). As Caserman et al. (2019) explained, this “enhances the sense of belief that the user is ‘present’ in the virtual environment” and behaves similarly as in reality.

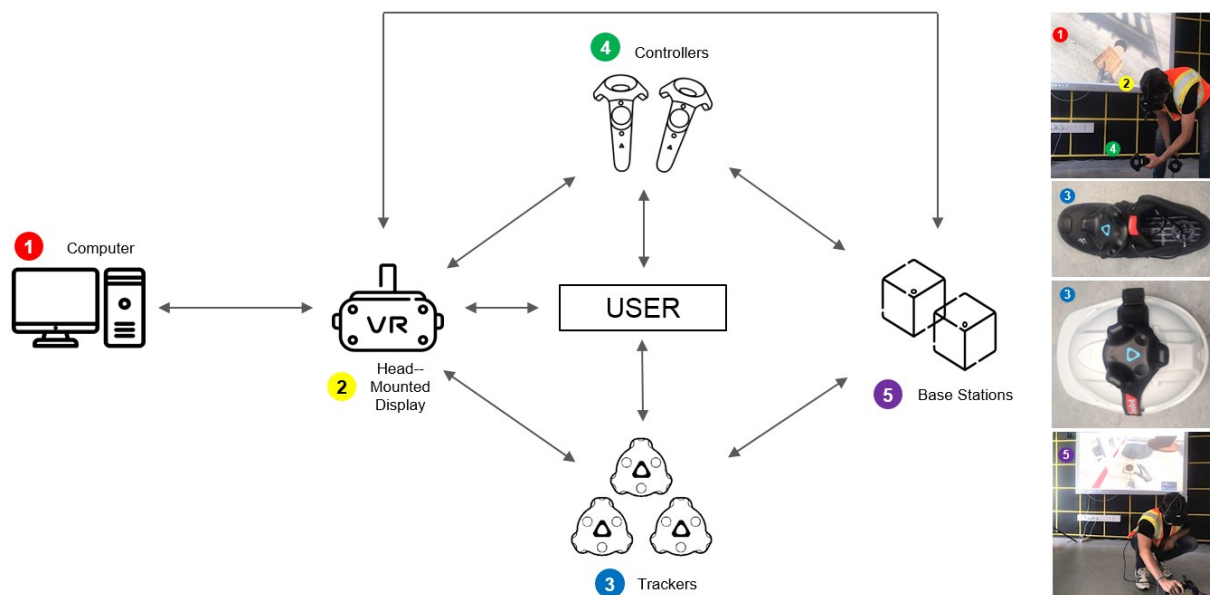


Fig. 5: Hardware in VR learning environment

3.2 Software

Numerous game engines have emerged and some of the most popular include Unity 3D (Rahimiana et al. 2020), Unreal Engine (UE4) and Amazon Sumerian. In this project, Unity 3D (2019.1.0f2) was used to create serious gaming experience. Blender was used to construct 3D objects, unless they were freely available from online stores. Unity 3D supports the scripting languages C# and UnityScript (Caserman et al., 2019). The architecture in the software is object-oriented design, which makes it easy to modify and use already existing features from other objects (Unity, 2020; Wang et al., 2010).

3.3 Run time data collection in VR

To measure both the safety and effectivity related performance of users while they execute a given work task (explained later), run time data loggers for head motion/eye tracking and feet tracking (using OnCollision, and OnTrigger) were built in the VR scene. The recordings register the timestamp (milliseconds) of the occurrence and the related information to an event, for example, when a user's eyesight or feet hit the corresponding collider (def. as an object modeled in the scene that represents a hazard). This being a barricade that is missing near a leading edge or a small opening in a concrete slab, for instance, likewise provides data to when a user's eye or foot, encounters (sees or hits) the object (hazard). A collider object typically comes in the form of an invisible spatial artifact (hazard space) to the user. Thus, recordings happen in the background without the user knowing (allowing unbiased data collection). Figure 6 illustrates the collider of a slab opening, where the collider is divided into the actual opening, a hole, and a nearby space (used for close-call recording and analysis (Hilfert et al., 2016)).

The software programmed allowed also the recording of the times when the user rectified one or both of the hazard(s) embedded in the scene: placing a guardrail to prevent falling from height or placing a cover on the concrete slab opening). Furthermore, performance of the user's work task, picking and placing 6 masonry bricks from/to two flat surfaces of wooden drums lying on the flange side. Overall, while a .CSV file allowed post-processing, run time data analysis was preferred.

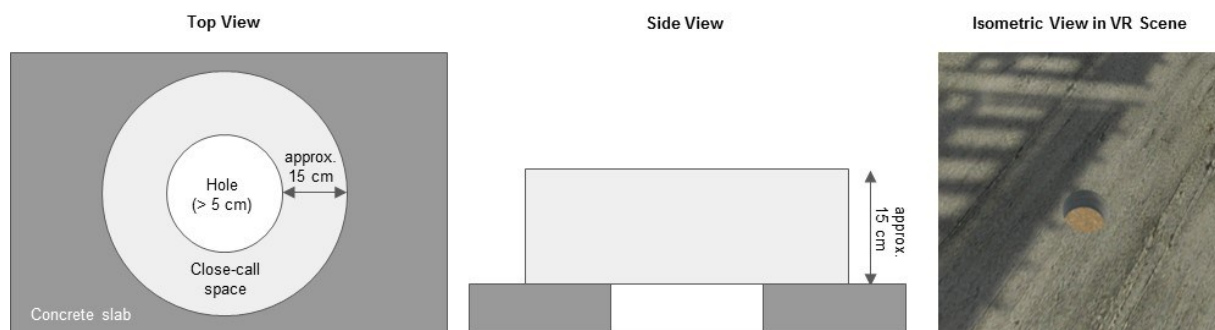


Fig. 6: Dimensions and visualization of floor opening hazard

4. IMPLEMENTATION

To test the performance of the volunteering participants, the following two scenarios are devised. The first scenario exists for introducing the user to VR and understanding the controls (moving the avatar and picking/placing objects) within the virtual scene. In the second scenario, the user(s) are tested for: (a) hazard detection and rectification, and (b) time needed in executing a basic task common in construction (e.g., picking and placing masonry bricks). For the second scenario, automatic in-game recorders collect data that is used in later performance analysis.

4.1 Scenario 1: User experience and training of VR controls

The first scenario was developed to explain users the controls and test their user experience in VR. The scenario also consists of a small pre-VR exercise; which is mainly conducted to explain the differences and objectives of a VR training environment compared to one in reality (Figure 7). Both expose the user to experience navigation with one difference: the VR scenario represents "walking the plank" (similar to Bosché et al., 2016) between two tall buildings under construction. While the user is tasked to move a helmet from one building slab to the other, the sole objective is to make the user familiar with (a) using the HTC Vive controllers and trackers and (b) providing a basic sense of the level of realism for navigating within VR scenes.



Fig. 7: Scenario 1 "walking the plank" in reality and in virtual reality to experience controls and haptics in VR

4.2 Scenario 2: Process from Synthetic Data Collection to Analysis

The second scenario was developed to measure the participants' perception of realism, safety awareness and ability to detect and rectify hazards in VR. Scenario 2 takes place on the first floor of a building under construction (Figure 7). Various common construction objects are present in the scene. Five barricades frame a work area, where two wooden drums provide two surfaces. On one surface, 6 bricks are loosely stacked. A few safety hazards are present in the scene: One small floor opening in the concrete slab located between the drums, causing hazard potential for a slip and trip incident, and one missing guardrail element protecting the avatar from falling off the leading edge. The objective for the user in the scenario is to safely move all bricks from one drum over to the other. While measures to rectify the hazards are available in the scene (an extra guard rail element and a cover), the task can be completed without rectifying the hazards.

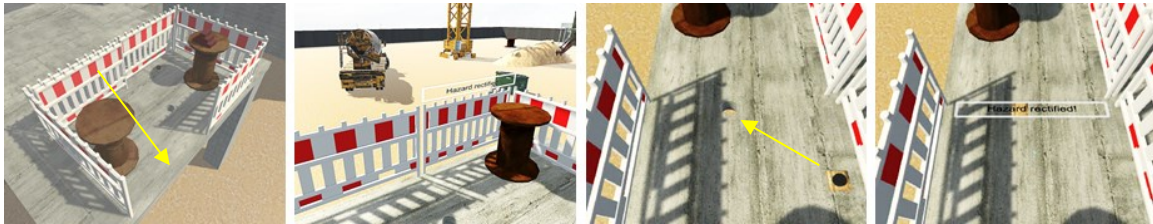


Fig. 7: Unresolved and solved leading edge and floor opening hazards (left and right images, respectively)

Furthermore, the success criteria are set to measure the performance of the users:

- The bricks are moved correctly when the in-game recorders register that all bricks are picked up and all bricks are placed and a 'Test completed.' message is displayed for the user at the end of the test.
- The safest sequence to rectify the hazards is to first apply the cover to the opening, then to place the extra guardrail element. The reason for this is that the participant risks to step into the opening while rectifying the missing 'falling from height' hazard.
- A hazard is detected when the participant's gaze-line and the hazard object collide.
- A close-call is recorded when one of the avatar's feet and the extended space to the floor opening collide.

These criteria were not shared with the users before conducting the test.

5. PRELIMINARY RESULTS

The participants are evaluated in run time based on in-game data recordings as described in the methodology section. The participants are evaluated based upon: Start and end time in VR scene; time needed to detect and rectify the hazard(s); number of steps in the opening and close-call encounters; time required to move bricks; and number of bricks moved correctly. The data can be seen in Figure 8.

From the automated data collected in Unity 3D, it is possible to analyze and evaluate basic safety as well as productivity performance of each user. For example, Figure 8 illustrates the start and end times of each participant. Thereof, users 1 and 9 took the longest time to complete the task. The average completion time of all users was about 66 seconds (Table 1). Figure 8 further shows the times in the tests when the users detected and rectified the embedded hazards (slab opening, leading edge) in the scene. From that, users 3 and 5 managed to detect the hazard(s), but neither of them rectified any of the hazard(s). The average time for all users from detecting to rectifying a hazard was around 22 seconds and the average number of hazards rectified was 1.33 out of 2 (Table 1). Figure 8 also displays the time recording the participants stepped into the hazard(s) and caused a close call. Users 5 and 7 had the most incidents (steps in opening, close-calls), where users 2, 6, 8 and 9 performed well and did not have any such incidents. The average number of incidents was 4.33 per user (Table 1). Figure 8 finally shows the points in time when the users picked up and placed the masonry bricks. It revealed that participants 1 and 9 started to move the bricks after the longest waiting period, that user 5 only managed to move 4 out of 6 bricks correctly and that users 8 and 9 figured out to increase the productivity by using both hands to move two bricks at a given time. The average time for moving all bricks correctly was around 40 seconds (Table 1). No user dropped off the leading edge.



Fig. 8: Analysis of synthetic data (timestamps) recorded of users in VR, from top to bottom: Start/end time of user experience, detection/rectification of two hazards (leading edge and floor opening), picking/placing masonry bricks as work task, and steps-in/close-calls in floor openings.

A total of 173 data points were generated from testing 9 users. The individual evaluation of each user will be conducted in the following.

- User 1 started out slowly, needing 31.86 seconds before any action was recorded. This took substantially longer than other users who needed only on average 8.49 seconds (Table 1). This user also detected the opening first before stepping inside it and only then rectifying the hazard. Furthermore, the user required the most time of all users to complete the test.
- User 2 was performing well and detected both the opening and missing guardrail within a short time and managed to rectify the hazards shortly after in the safest sequence; first applying the cover and then the

extra guardrail. All 6 bricks were moved after rectifying the hazards and with the fastest average time of all users at 1.26 seconds per brick.

- User 3 was the fastest of all to detect both hazards. Although, this user did not rectify any of them. Instead, the participant started to move the bricks and had various incidents (steps in opening and close-calls). The user completed the handling of the bricks in the second fastest time, as no time was used to rectify the hazards.
- User 4 learned from his mistakes. The user stepped in the hole while moving the first brick, then detected the hole and rectified it immediately before moving the remaining bricks. Although, user 4 did not seem to acknowledge the missing barricade as a hazard at first and only rectifies the hazard after moving two additional bricks.
- User 5 was performing worst both in terms of completing the task and safety. The user only detected the missing protective guardrail element and did not even look down to see the opening in the concrete slab. He did not rectify any hazard. User 5 stepped in the opening 15 times (worst of all) and had 5 close-calls of stepping in the opening again (worst of all). This was far worse than the average of 3.33 steps in the opening and the average of 1.00 close-calls in stepping in the opening again (Table 1). In addition to this, the user dropped or threw two bricks (by releasing the hand control early) making him the only user who did not complete the movement of the 6 bricks. The average time for moving one brick was likewise the worst among all with 8.53 seconds, where the average user took 2.93 seconds (Table 1).
- User 6 detected both the hole and missing guardrail element right at the beginning and moved one brick slowly and without stepping in the opening. After moving the first brick, the user covered the hole in the slab and moved the 5 remaining bricks quickly. This could indicate that the user was aware of the hazard and was careful not to step in it before he rectified it. The user although did not seem to acknowledge the missing guardrail as a hazard and did not manage to rectify it.
- User 7 detected the missing guardrail when moving the first brick. After moving the first brick, he rectified the missing guardrail hazard but while doing this, the participant stepped into the opening 4 times and had 1 close-call. The user never detected or rectified the opening, but managed to move the bricks quicker than the average.
- User 8 used both hands to move two bricks at a time. This approach revealed that the time for moving two bricks using both hands are twice as effective as moving one brick with one hand. It is although safer to always have one hand free in case of slips or trips. He does not have any incidents, but only managed to rectify the hazards after the first four bricks were moved.
- User 9 detects and rectifies both hazards before moving any of the bricks. Although, the user rectifies the hazards in the least safe sequence; first the missing guardrail, then the opening. The user's performance increased as he moved the bricks. He started moving the first brick only using one hand, but realized that moving two bricks at a time was more effective and moved bricks 2 and 3 and bricks 4 and 5 at the same time. This resulted in a total duration for moving all the bricks of 25.51 seconds being the fastest time among all participants, where the average was 39.59 seconds (Table 1).

Table 1: Results to all participants (9)

Evaluation parameter	Average
Time before first action recorded [s]	8.49
Completion time [s]	66.44
Bricks moved correctly [number]	5.78
Average time for moving one brick [s]	2.93
Time for moving all six bricks correctly [s]	39.59
Steps in hole [number]	3.33
Close-calls (<i>almost</i> stepped in hole) [number]	1.00
Total number of incidents [number]	4.33
First time stepped into hole [s]	17.44
Last time stepped into hole [s]	45.37
Barricade (from detection to rectification) [s]	27.36
Hole (from detection to rectification) [s]	16.84
A hazard (from detection to rectification) [s]	22.10

6. DISCUSSION

The results obtained in this preliminary research shows that it is possible to group and compare participants by performance both in terms of effectivity and safety by using automated run time data collectors. Similar to that, Bükürü et al. (2020a) discovered “that VR- and AV-based training can provide previously unobserved data objectively” by automated in-game data collection.

The performance data of this research can help identifying the specific safety training needed for each participant to succeed and improve safety cognition. For example, user 3 detected both hazards, but did not rectify any of them and started to move the bricks immediately. This could indicate that the user does not understand the types of hazards which can exist at workplaces or that the user needs training in understanding how to rectify the hazards.

The overall best safety performance was accomplished by user 2. He identified and rectified the hazards in the safest order and even managed to move the bricks effectively and faster than the average time. User 7 performed poorly in terms of safety performance (e.g., stepped in the opening several times), but managed to detect and rectify the missing guardrail which could indicate a lack of workplace safety overview before starting work.

In brief, applying the automated in-game data collector is crucial to understand the users’ construction safety knowledge and how to improve it in details. Such knowledge does not exist in most 3D visualizations or serious games in VR for safety education and training. Through this serious game development, it became clear that obtaining similar data to the data provided by the automated in-game recorders would be (1) very time-consuming and in some cases (2) impossible to achieve by using manual data collection methods. For instance, precise recording when each brick is picked up and placed is time-consuming and it is impossible for by-standers (e.g., safety educators) to count and analyze larger numbers of mishaps or close calls without adequate computer technology.

Through serious game in VR development, it was found that balancing the in-game information flow to the user can be challenging. It should be a balance between providing enough information back to the user to be able to solve the task correctly and not providing too much information, eventually discouraging the user from participating in future learning. The information provided to the user in Scenario 2 is therefore limited to “Hazard rectified!” once the hazard is rectified. When all bricks are moved correctly, feedback in form of a brief text “Test completed!” is given. The provided feedback was felt by the user positively, given them a rewarding feeling and this a learning experience that gamification has potential in hazard detection and rectification.

The limitations of this research count the limited number of users and the fact that the data are synthetically recorded. Enlarging the number of users would have increased the liability of the analysis, grouping and understanding of the participants’ performance.

The limitation of this research also relates to technical matters of the implementation. For example, a discussion was raised whether a hazard is detected, recognized, or only gazed at. In the second scenario, a hazard is recognized when the hazard is gazed at once the ray cast line is recorded to collide. This has the potential to lead to erroneous data collection. For instance, the time delay between a user observing a hazard in the beginning (according to the in-game recorder) and (later) rectification matters. To differentiate between observation/gaze and recognition, two approaches could be applied: Either by interviewing participants making it possible to clarify any potential misinterpreted data or by setting criteria for the definition of recognition (i.e., a hazard is recognized after a specific gaze-time set a priori as suggested by Bükürü et al. (2020b)). Neither approach is although impeccable. The interview approach could be biased and subjective. The criteria approach is game-specific and depends on the complexity of the gazed objects. The average gaze time can be logged and evaluated based on the reaction of the user. However, it is important to note that the latter approach is more data-driven, but it requires additional research focus to understand the recognition of the hazard with the respective reaction. A final limitation relates to the evaluation methods. Here, questionnaires or interview could have provided better understanding if the research objective were met.

7. PRELIMINARY CONCLUSIONS AND OUTLOOK OF FUTURE WORK

Conventional training and practices seem somewhat ineffective compared to active learning. Still, too few construction safety education and training approaches are focusing on including advanced and immersive technologies. This research presented two virtual scenarios, one for making users comfortable using VR and the second for testing hazard awareness and control. Both scenarios represent a real-life hazardous situation in a safe

virtual environment without the risk of endangering the user's life or health. The novelty of this research is a framework for the generation and automated assessment of VR user data in VR. This would help focusing on the individual's performance in terms of (primary objective) safety education training, cognition and (secondary objective) work task effectivity by using run time data collectors in (for example) Unity 3D in a serious gaming environment. From the results and discussion, it can be concluded that automated run time recorders can provide objective data not possible to obtain in non-computerized training. The results indicate the potential for evaluating safety cognition of users and their needs for safety training. Future work will include the testing of more users and perhaps on developing more task-specific serious games with rapid and direct user feedback. Other future work must emphasize the shortcoming originating from motion sickness, likely issues with GDPR (General Data Protection Regulation), and long term psychological effects of exposing users to hazardous situations and even death in VR. Furthermore, a comprehensive study in the Nordic countries on VR in construction safety, health, and well-being education and training would be needed to fully conclude the effects, limitations and the potential penetration in a single market. Likewise, research in other markets could investigate fundamental differences in workforce safety behavior on an international level.

8. REFERENCES

- Borrego, A., Latorre, J., Alcaniz, M., and Llorens, R. (2018). Comparison of oculus rift and htc vive: feasibility for virtual reality-based exploration, navigation, exergaming, and rehabilitation. *Games for Health Journal*, 7(3):151–156. doi: <https://doi.org/10.1089/g4h.2017.0114>.
- Bükrü, S., Wolf, M., Böhm, B., König, M. and Teizer, J. (2020a). Augmented Virtuality in Construction Safety Education and Training. *European Group for Intelligent Computing in Engineering Conference (EG-ICE)*, Berlin, Germany, July 1-4, 2020, p. 115-124.
- Bükrü, S. Wolf, M., Golovina, O., Teizer, J. (2020b), Using Field of View and Eye Tracking for Feedback Generation in an Augmented Virtuality Safety Training. *Construction Research Congress*, Tempe, Arizona, USA.
- Burke, M. J., Sarpy, S. A., Smith-Crowe, K., Chan-Serafin, S., Salvador, R. O., and Islam, G. (2006). Relative effectiveness of worker safety and health training methods. *American Journal of Public Health*, 96(2):315–324.
- Bosché F., Abdel-Wahab M. S., Carozza L. (2016). Towards a mixed reality system for construction trade training. *Journal of Computing in Civil Engineering*, 04015016.
- Caserman, P., Garcia-Agundez, A., Konrad, R., Göbel, S., and Steinmetz, R. (2019). Realtime body tracking in virtual reality using a Vive tracker. *Virtual Reality*, 23(2):155–168. <https://doi.org/10.1007/s10055-018-0374-z>.
- Cheng, T., Yang, J., Teizer, J. and Vela, P.A. (2010). Automated Construction Resource Location Tracking to Support the Analysis of Lean Principles. *18th Annual Conference of the International Group for Lean Construction*, Haifa, Israel, July 14-16, 2010, 643-653.
- Cheng, T., Migliaccio, G. C., Teizer, J., and Gatti, U. C. (2013). Data fusion of real-time location sensing and physiological status monitoring for ergonomics analysis of construction workers. *Computing in Civil Engineering*, 27(3):320–335. [https://doi.org/10.1061/\(asce\)cp.1943-5487.0000222](https://doi.org/10.1061/(asce)cp.1943-5487.0000222).
- Chi, H. L., Kang, S. C., and Wang, X. (2013). Research trends and opportunities of augmented reality applications in architecture, engineering, and construction. *Automation in Construction*, 33:116–122.
- Dale, E. (1954). *Audio-Visual Methods in Teaching*. Revised edition. New York: The Dryden Press.
- Danmarks Statistik (2020). *Beskæftigede ved bygge og anlæg efter branche*. <https://www.statistikbanken.dk/>.
- Dansk Arbejdsgiverforening (2019). *Stabilt ulykkesomfang over de senere år*. <https://www.da.dk/statistik/ulykkesstatistik/ulykkesstatistik-2018/>, Accessed on 15.02.2020.
- de Vries, M. J. (2018). The Importance of the Conceptual in Progressing Technology Teaching and Learning. *Nature*, <https://doi.org/10.1007/978-3-319-44687-5>.
- Dominguez, A., et al. (2013). Gamifying learning experiences: Practical implications and outcomes. *Computers & Education*, 63:380–392.
- Dunston, P. S. and Wang, X. (2011). An iterative methodology for mapping mixed reality technologies to AEC operations. *Information Technology in Construction*, 16(30):509–528. [https://doi.org/10.1061/40754\(183\)123](https://doi.org/10.1061/40754(183)123).
- Eisenberg, A. (2010). Bye-Bye Batteries: Radio Waves as a Low-Power Source, *New York Times*, <https://www.nytimes.com/2010/07/18/business/18novel.html>, Accessed July 7, 2020.
- Fang, Y. and Teizer, J. (2014). A Multi-user Virtual 3D Training Environment to Advance Collaboration Among Crane Operator and Ground Personnel in Blind Lifts. *Intl. Conference on Computing in Civil and Building Engineering Conference*, Orlando, Florida, June 2014, 2071-2078, <https://doi.org/10.1061/9780784413616.257>.
- Getuli, V., Capone, P., Bruttini, A., Isaac, S. (2020). BIM-based immersive Virtual Reality for construction workspace planning: A safety-oriented approach. *Automation in Construction*, 114, 103160.
- Guo, H., Li, H., Li, C., Li, G., and Skitmore, M. (2012). Using game technologies to improve the safety of construction plant operations. *Accident Analysis & Prevention*, 48:204–213. <https://doi.org/10.1016/j.aap.2012.03.011>.
- Hilfert, T., Teizer, J., König, M. (2016). First Person Virtual Reality for Evaluation and Learning of Construction Site Safety. *33rd International Symposium on Automation and Robotics in Construction*, Auburn, Alabama, USA.

- Holt, A. S. J. (2001). *Principles of construction safety*. Wiley Online Library.
- Horswill, M. S., Marrington, S. A., McCullough, C. M., Wood, J., Pachana, N. A., McWilliam, J., and Raikos, M. K. (2008). The hazard perception ability of older drivers. *The Journals of Gerontology Series B: Psychological Sciences and Social Sciences*, 63(4):212–218. <https://doi.org/10.1016/j.aap.2011.05.035>.
- Hu, K., Rahmandad, H., Smith-Jackson, T., and Winchester, W. (2011). Factors influencing the risk of falls in the construction industry: a review of the evidence. *Construction Management and Economics*, 29(4):397–416.
- Januszewski, A. and Molenda, M. (2013). *Educational Technology - A Definition with Commentary*. Routledge.
- Kassem, M., Benomran, L., Teizer, J. (2017). Virtual environments for safety learning in construction and engineering: seeking evidence and identifying gaps for future research. *Visualization in Engineering*, 5:16.
- Vinnueftirlitid (2020). Skýrslur 2010-2018. <https://www.vinnueftirlit.is/fraedsla/utgefifid-efni/skyrslur> (1.7.2020).
- Li, H., Chan, G., and Skitmore, M. (2012). Visualizing safety assessment by integrating the use of game technology. *Automation in Construction*, 22:498–505. <https://doi.org/10.1016/j.autcon.2011.11.009>.
- Li, X., Yi, W., Chi, H. L., Wang, X., and Chan, A. P. (2018). A critical review of virtual and augmented reality (vr/ar) applications in construction safety. *Automation in Construction*, 86:150–162.
- Looser, J., Billinghamurst, M., and Cockburn, A. (2004). Through the looking glass: the use of lenses as an interface tool for augmented reality interfaces. *2nd Intl. Conf. on Computer Graphics and Interactive Techniques in Australasia and South East Asia*, 204–211. <https://doi.org/10.1145/988834.988870>.
- Lu, X. and Davis, S. (2016). How sounds influence user safety decisions in a virtual construction simulator. *Safety Science*. <https://doi.org/10.1016/j.ssci.2016.02.018>.
- Melzner, J., Teizer, J., Zhang, S., Bargstädt, H.-J. (2013). Objektorientierte sicherheitstechnische Planung von Hochbauprojekten mit Hilfe von Bauwerksinformationsmodellen. *Bauingenieur*, 11, ISSN 0005-6650, 471-479.
- Muntean, C. I. (2011). Raising engagement in e-learning through gamification. *Conf. Virtual Learning*, 1:323-329.
- Nielsen, J. and Molich, R. (1990). Heuristic evaluation of user interfaces. *Proc. Human Factors in Computing Systems*, 249-256. <https://doi.org/10.1145/97243.97281>.
- Park, C. S. and Kim, H. J. (2013). A framework for construction safety management and visualization system. *Automation in Construction*, 33:95–103.
- Rahimiana, F.P., Seyedzadeh, S., Oliver, S., Rodriguez, S., Dawood, N. (2020). On-demand monitoring of construction projects through a game-like hybrid application of BIM and machine learning. *Automation in Construction*, 110, 103012, <https://doi.org/10.1016/j.autcon.2019.103012>.
- Rosenberg, L. B. (1993). The use of virtual fixtures as perceptual overlays to enhance operator performance in remote environments, *Telem manipulator Technology & Space Telerobotics*, 2057, <https://doi.org/10.1117/12.164901>.
- Sacks, R., Perlman, A., and Barak, R. (2013). Construction safety training using immersive virtual reality. *Construction Management and Economics*, 31(9):1005–1017, <https://doi.org/10.1080/01446193.2013.828844>.
- Settles, B. (2011). From theories to queries: Active learning in practice. *Machine Learning Research*, 16, 1-18.
- SSB (2019). Bygge- og anleggsvirksomhet, strukturstatistikk. <https://www.ssb.no/stbygganl>, Accessed 15.02.2020.
- Statista (2019). Total number of employees in the construction industry in Finland from 2010 to 2016. <https://www.statista.com/statistics/432470/number-employeesconstruction-industry-finland>, accessed 17.02.2020.
- Statistikdatabasen (2019). Sysselsatta från och med 1970. https://www.statistikdatabasen.scb.se/pxweb/sv/ssd/START__AM__AM0401__AM0401I/, Accessed 17.02.2020.
- Steuer, J. (1992). Defining virtual reality: Dimensions determining telepresence. *Journal of Communication*, 42(4):73-93. <https://doi.org/10.1111/j.1460-2466.1992.tb00812.x>.
- Stošić, L. (2015). The importance of educational technology in teaching. *Cogn. Research in Science*, 3(1):111-114.
- Su, C.-H. and Cheng, C.-H. (2015). A mobile gamification learning system for improving the learning motivation and achievements. *Journal of Computer Assisted Learning*, 31(3):268-286. <https://doi.org/10.1111/jcal.12088>.
- Teizer, J., Cheng, T., and Fang, Y. (2013). Location tracking and data visualization technology to advance construction ironworkers education and training in safety and productivity. *Automation in Construction*, 35:53-68.
- Teizer, J. (2016). Right-time vs. real-time pro-active construction safety and health system architecture. *Construction Innovation: Information, Process, Management*, 16(3), 253-280.
- Unity (2020). Scripting in unity for experienced programmers. <https://unity.com/howto/programming-unity>.
- van de Ven, A.H. and Johnson, P.E. (2006). Knowledge for theory and practice. *The Academy of Management Review*, 31(4):802–821. <https://doi.org/10.5465/amr.2006.22527385>.
- von Heyl, J. and Teizer, J. (2017). Lean Production Controlling and Progress Tracking Using Digital Methods. *25th International Group for Lean Construction*, Heraklion, Greece, 127-134. <https://doi.org/10.24928/2017/0238>.
- Wang, S., Mao, Z., Zeng, C., Gong, H., Li, S., and Chen, B. (2010). A new method of virtual reality based on Unity3D. *18th Intl. Conference on Geoinformatics*, 1-5. <https://doi.org/10.1109/geoinformatics.2010.5567608>.
- Zhou, W., Whyte, J., and Sacks, R. (2012). Construction safety and digital design: A review. *Automation in Construction*, 22:102–111. doi: <https://doi.org/10.1016/j.autcon.2011.07.005>.

DEVELOPING A MIXED-REALITY BASED APPLICATION FOR BRIDGE INSPECTION AND MAINTENANCE

Duy Cuong Nguyen, Chang Su Shim

Chung-Ang University, South Korea

The Quan Nguyen

National University of Civil Engineering, Vietnam

Ruoyu Jin

London South Bank University, United Kingdom

Chi Ho Jeon

Chung-Ang University, South Korea

ABSTRACT: *Bridge inspection, which collects data for assessment and decision-making processes, plays an important role in the maintenance job of bridge structures. However, all of the inspection jobs, including general inspection, principal inspection and special inspection, generate large and unstructured data resulting in ineffective maintenance. Besides, traditional inspection generates only 2D-based and less visionary information. For a more reliable assessment of structures, it is necessary to improve the current inspection technology and process. In recent years, mixed reality (MR) technology has been proved to be effective in improving interaction, communication and collaboration among stakeholders for evaluating the database. MR and holographic technology blend 3D models with physical assets and support users to engage in the models and interact with the project data more intuitively in the real-time simulation. This paper presents an application of MR-based system called HoloBridge to enhance and facilitate bridge inspection and maintenance. The application consists of modules of inspection, evaluation, and damage mapping. The HoloBridge application is being deployed to Microsoft HoloLens for tracking and assessing conditions of bridges. The application has been developed by building information modelling (BIM)-based system linked and integrated into a cross-platform game engine to evaluate bridge damage information. The application is piloted with a highway bridge in South Korea and has shown the benefits not only in the digitalized inspection processes, but also in systematic managing bridge performance.*

KEYWORDS: *Mixed reality, building information modelling, bridge inspection and maintenance.*

1. INTRODUCTION

In the construction 4.0 revolution, promising technologies such as building information modelling (BIM), virtual reality (VR), augmented reality (AR), mixed reality (MR) that promote digitization and automation in information management and visualization. MR technology shows the reality-virtuality continuum, which is the process of blending the 3D project model in real-world representation based on computing techniques. MR system is an innovation for project information interaction and collaboration among stakeholders (Dunston & Wang, 2005). It enables to enhance data accessibility for decision making in project management such as design check, construction simulation and monitoring, especially for operation and maintenance. MR goes beyond the AR-VR technology by combining the features of both VR and AR. VR environment provides a computer-generated reality wherein the user can completely immerse and interact with model objects using a VR headset. Rather than fully immersive in a virtual environment, AR enhances model interaction between the virtual and the real worlds via smartphones, tablets and AR glasses. According to Rokhsaritalemi (2020), three main characters of MR are immersion, interaction and information. Immersion refers to the act of user completely immersing oneself into the virtual-reality world by real-time interaction. In the MR environment, the user interacts with the object to access information by natural communication modes such as gestures, voice, and gaze. However, the development of MR technology faces two significant challenges: display technology and tracking. An MR application needs to display the output model with high resolution and contrast. The interaction between virtual models with the user's command requires precise and fast methods. For MR-based application development, the Microsoft HoloLens has been introduced as the most prominent MR device. Microsoft HoloLens is the first self-contained, holographic computer that allows users to engage with 3D digital content and interact with holograms in a hybrid reality. With the HoloLens, users can bring the 3D project model to the real-world to collaborate with others by hands and voices. Since BIM adoption becomes popular in the construction sector, the BIM-based system has been proven as an

effective solution for project information management based on a 3D model working environment (Demian & Walters, 2014). Hence, combining an MR system and BIM can create a powerful application for project information management and visualization.

In recent years, the MR-based application for BIM system using Microsoft HoloLens has been implemented in the field of Architecture, Engineering and Construction (AEC). An AEC project contains huge amount of information that requires be accessed from various parties such as contractor, owner and consultancy. By using HoloLens, the BIM model in holographic environments is able to share construction-related information among different stakeholders that improve collaboration, coordination and understanding project documents (Hamzeh et al., 2019). In addition, using MR application for assembly instruction also reduces the installation errors and improve productivity in the construction site (Huang et al., 2019). In modern infrastructure development, bridges are the most expensive, complex structure. Therefore, the transportation agency needs to have a smart application for managing inspection and maintenance tasks. Bridge inspection is the process of determining the physical and functional condition of bridge structures. It is the main component of bridge monitoring and maintaining work, which provides the safety assessment and condition document for the bridge management system. During the bridge operation phase, the inspection work consists of the general inspection, principal inspection, and special inspection by various inspection methods and technologies. A huge amount of inspection data has been generated. The inefficient information system leads to incorrect safety assessment for maintenance works. Moreover, the limitation of monitoring the deterioration process is the lack of digitalized damage records to compare the current inspection results with the previous inspection. It requires a single-source data model, which can systematically manage the inspection database and ability to interact with the dataset.

Therefore, to solve this problem, the paper presents the development of HoloBridge application for Microsoft HoloLens to improve the inspection and maintenance tasks based on the advance of BIM-based system and MR technology. The pilot implementation shows the result of BrIM inspection model in the MR environment. The application can support better decision-making by the function of information sharing, visualization, integration and real-time interaction among project stakeholders.

2. LITERATURE REVIEW

Bridge information model (BrIM) is an integrated model, which includes a three-dimensional (3D) model and a bridge database. BrIM enables stakeholders to collaborate and manage works throughout the project lifecycle, from planning to maintenance (Shim et al., 2012). Recently, this BIM-based system has been widely adopted to improve bridge inspection and maintenance (McGuire et al., 2016; Shim et al., 2017). The process of integration of the inspection and maintenance information to a BrIM can improve the decision-making process and lead to more quality decisions. The most advanced feature of BIM is the facilitation of data exchange, integration and interoperability in digital formats during the project lifecycle (Eastman et al., 2011). For inspection work, the defect information is extracted and modelled to overlap with BIM element model (Hüthwohl et al., 2018; Sacks et al., 2018). The prototypical implementation proves the possibility of integrating inspection data with a 3D model to create a BIM-based inspection model. Moreover, the BrIM inspection model also can minimize the error from the inspector's personal evaluation and reduce the time by using 3D model visualization for better understanding bridge structure (Al-shalabi et al., 2015).

Literature shows that BIM has been utilized for developing VR, AR, MR applications. For project operation and maintenance, Omer (2019) developed a VR application to bring bridge inspection in the office. The application uses 3D models developed from the 3D scanned data, and the user can walk in this virtual environment to check the condition of the bridge structures. The inspection work using VR technology overcomes the limitation of the conventional method. AR technology also has been investigated and applied in bridge inspection work (Salamak & Januszka, 2018). Although VR, AR technology have been successfully applied in bridge inspection work as a new approach to improve the quality of damage visualization and detection, the application of MR has many limitations, particularly for the HoloLens application. HoloLens is a wearable device that can be used to inspect bridges in the field and office. Previous researches have focused on developing the HoloLens application for onsite bridge inspection (Karaaslan et al., 2019; Moreu et al., 2017). By using HoloLens, users can automatically detect some types of defects such as crack, spalling with dimension information in real-time. However, there is a lack of research on using HoloLens application for remote bridge inspection in the office. It is necessary to develop a framework to build a HoloLens application for bridge inspection from a BIM-based system and onsite inspection database.

3. METHODOLOGY

This research aims to highlight the capability of inspection data visualization and interaction in MR space and the systematic database management based on BrIM model to develop a smart MR-based application for enhancing and facilitating bridge inspection and maintenance. The critical review of the literature is conducted to realize the limitation and challenge of the current AR, MR application in terms of BIM model for inspection, data visualization, integration, and analysis for monitoring the structural condition. To achieve the research aim, a new framework, a BrIM model for inspection and maintenance, and a development workflow are proposed. To develop the application, a framework is created from the concept of a BIM-based system for inspection and the feature of MR-based application. The BrIM model for inspection is built based on the parametric modeling and systematic integration of inspection databases. Finally, the application has been implemented for a case study bridge to evaluate the effectiveness of inspection and maintenance works.

3.1 General MR application framework

This framework has four major parts: (I) Data acquisition, (II) Data processing, (III) BIM-based system, and (IV) Application development (see Figure 1). This paper mainly focuses on the BIM-based system for bridge inspection and application development process. Part I and II are the data preparation process to establish a BIM-based system. Ultimately, the application has been developed through a cross-game engine platform and a BIM system.

Data acquisition is the process of gathering bridge information from different inspection levels such as general, principal and special inspection by modern bridge inspection technologies. For visual inspection, a drone is used to simplify complex inspection tasks with high quality of photos and videos. The drone data provides a database to generate a 3D bridge scan model by photogrammetry technique. The scan model provides geometric data with defects visualization. Besides, ground-penetrating radar (GPR) is used to capture the subsurface of the concrete and pavement for detecting the damages such as delamination, voids. In the data processing, the inspection documentation is generated with the detail damage properties from the damage detection, classification and measurement process. The BIM-base system consists of two major components, which are the 3D bridge information authoring and the database from the data processing part. The 3D bridge structure model is created with the corresponding inventory system. Each bridge element model contains model attribute, archive data and a link to the inspection database. Finally, the HoloBridge application can be developed from a cross-platform game engine and BIM models. The application brings the 3D bridge model to the real-world and allows the user to query the inspection database to check and monitor the structural condition. By the damage mapping algorithm, the user can evaluate the damage development progress over time and make a more reliable decision for maintenance works.

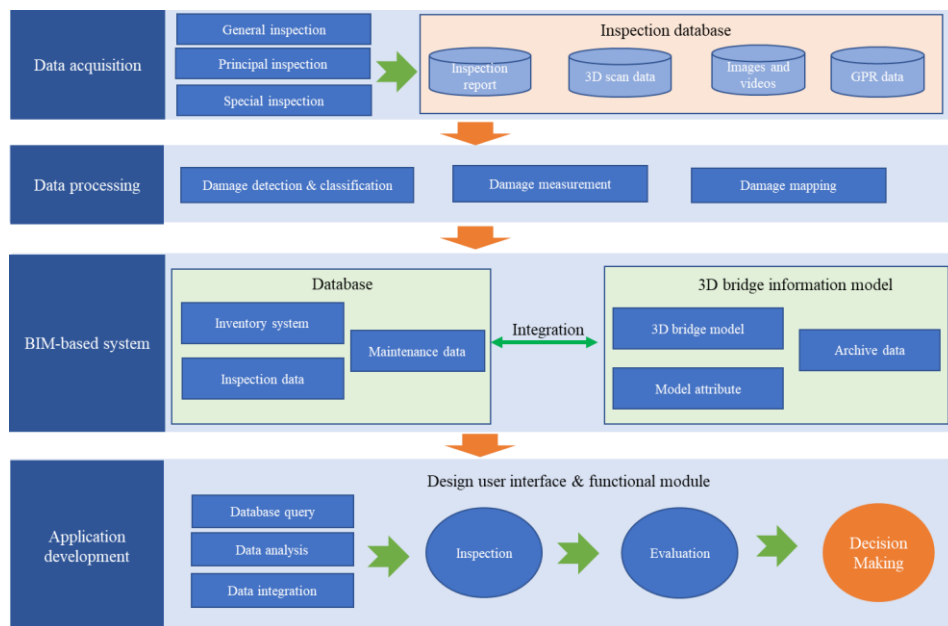


Fig. 1: Application framework

3.2 Case study bridge

The case study bridge is a PSC girder bridge built in 2001, 120-meter length with four spans (Picture in Figure 2). General, principal and special inspection jobs for the bridge have been conducted with modern technologies using a drone, laser scanning, and ground-penetrating radar (GPR). The most common damages are cracks and spalling on the piers, girders and bottom slab surfaces. The inspection data have been stored under 2D-based forms such as AutoCAD damage drawings, inspection photos and reports. The bridge was selected because the current management system has many limitations in terms of data interoperability and integration of the metadata. These data are discrete and not be linked between the current result and the previous result to monitor the damage development, especially for crack propagation. In order to systematically manage the inspection records, the bridge information model has been defined. This is a single-source data model, in which the inspection data of bridge structures have been integrated with 3D information element models.

The following sections describe the overview and the systematic process of BIM-based system for inspection and maintenance, explain the information exchange and relationship of the data model in the database system, and present the workflow of application development with the functional module. The conclusion section discusses the novel aspects of the application from BrIM model in MR environment working, and the extension for future works.



Fig. 2: Case study bridge

4. BRIDGE INFORMATION MODEL FOR INSPECTION AND MAINTENANCE

4.1 Bridge inventory system

The structural components are categorized and put into an inventory system based on their roles in the bridge system. Generally, the inventory includes the superstructures (e.g., slabs, girders, cross beams, barriers, bearings, expansion joints) and the substructures (e.g., bridge piers, abutments). The category system enables the identification of structural elements by using specific identifications (hereafter, ID) and create a systematic database. According to the ID definition, the 3D information model of bridge structures is generated by object-oriented modeling. The entire bridge model will be assembled by all elements' ID with coordinate and constraint data from bridge alignment. Figure 3 presents the inventory system with a detailed hierarchical category and ID naming convention.

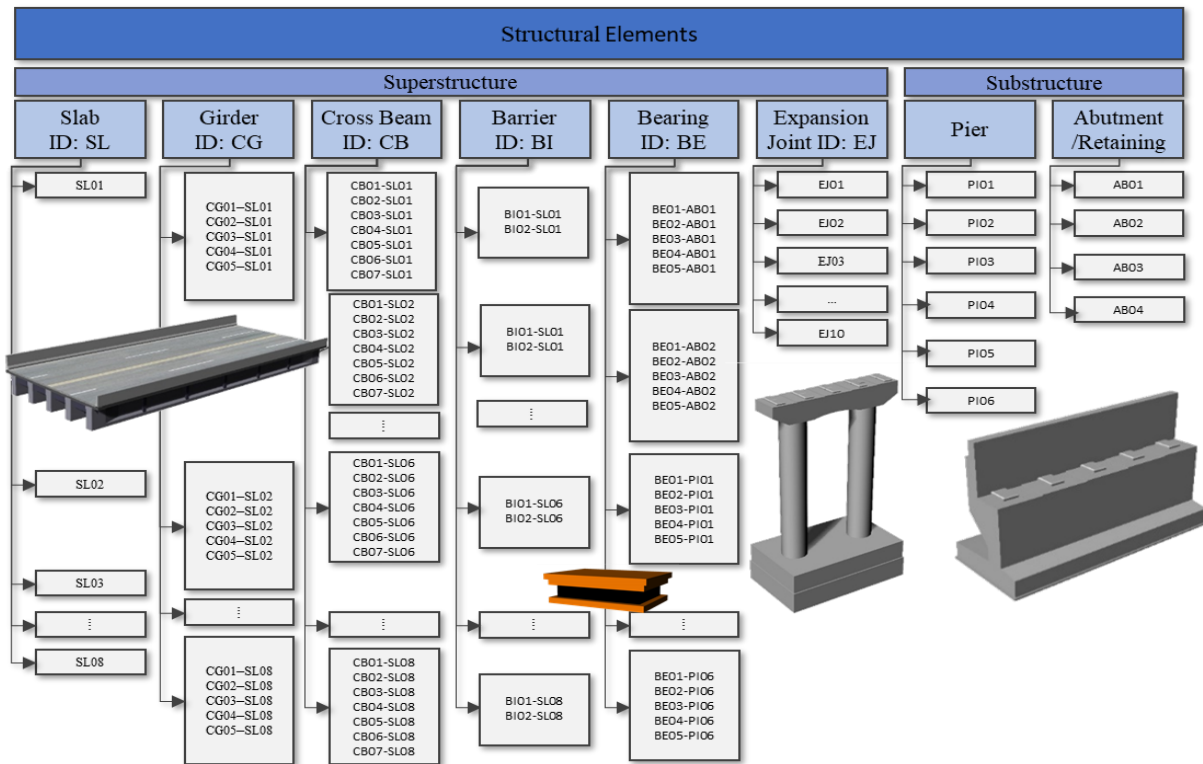


Fig. 3: Inventory system and ID definition

4.2 Model authoring

The creation of the BrIM model is an essential task in the BIM-based system establishment. According to the inspection and maintenance purpose, the BrIM model has been developed from 2D cad drawings in the level of development (LOD) 300. The model has three significant characteristics: structure recognition, relationship modelling and object-based parametric modelling. Structure recognition has a function to label the queried bridge components followed by the inventory system and ID definition. Relationship modelling establishes the topological relationship of bridge components. The object-based parametric modelling aims to generate a 3D digital representation of bridge components by the geometric parameters and modelling algorithms. Modelling algorithm is a mathematical calculation between geometric constraints and dimensions that allows automatically changing the shape of the model when the dimension value is modified. The advance of the parametric modelling method is flexible, fast and accurate because of using parametric features. Figure 4 explains a flowchart of bridge modelling authoring. There are four steps to make a parametric bridge model. First, the bridge element model needs to be defined from the inventory system with ID convention. Second, this step requires identifying the geometric and alignment parameter of each element. For instance, a bridge pier model comprises foundation, column and pier cap with the main geometric parameters such as length, width, height, radius and the position, orientation and constrain of the alignment parameter. Third, the object model is built based on the geometric and alignment algorithm. The geometric algorithm is the process of creating the geometric of an element model from the primitive shape such as curve, surface, solid in the Euclidean three-dimensional space. From the whole model structure and constrain of element objects, the alignment algorithm is created from the coordinate system and orientation vector. Similarly, the other elements can be modelled, such as abutment, girder, slab, and barrier. Finally, bridge substructures and superstructures models are placed in accordance with the 3D alignment-based parametric of the entire bridge model.

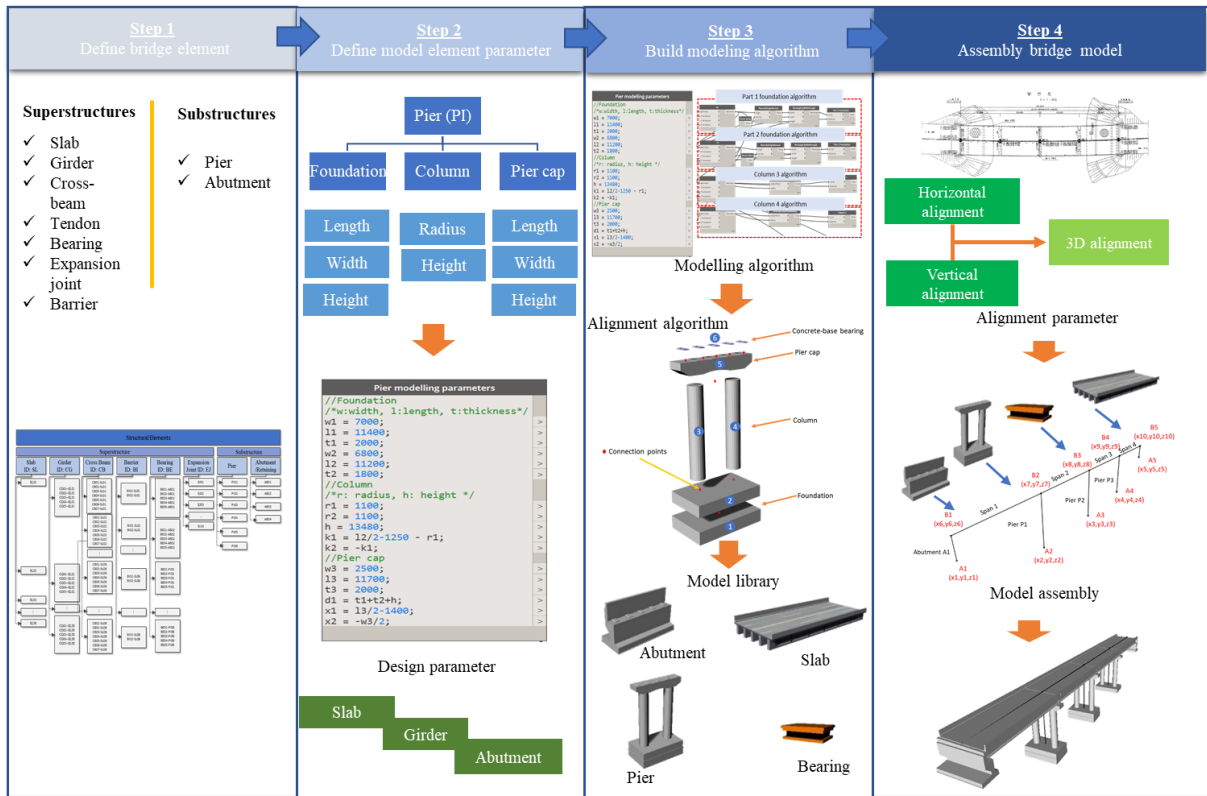


Fig. 4: Model authoring process

Figure 5 explains the process of converting the 3D foundation model from BIM platform to HoloBridge application. In this research, the bridge model from Dynamo is exported to Revit to finalize BIM models with the attribute and as-built information. From Revit, the bridge model is converted to the exchangeable 3D format, such as industry foundation classes (IFC) and FBX. In Unity 2019.3, a cross-platform game engine, the application has been developed with the programming of functional modules for inspection works. After the bridge model has been established, the application database is constructed with the systematic structure and data integration architecture.

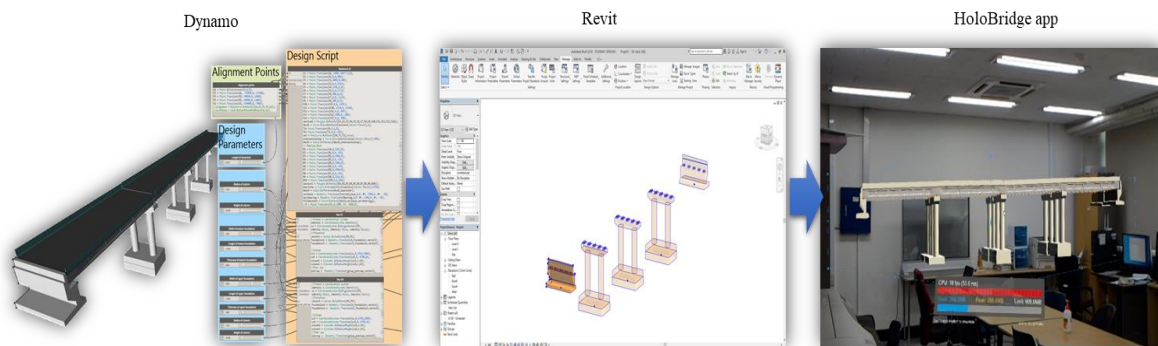


Fig. 5: Importing model to application

4.3 Database system

The application database has three main parts: inspection and maintenance data storage, 3D BIM foundation model, and data integration architecture. The inspection and maintenance data are commonly managed by various reports. The data accumulation and curation can be efficiently organized by BIM model-based and mixed-reality platform features. The bridge BIM-based database is built by integrating the corresponding data into the specific 3D structure model based on systematic classification from the inventory system. In the database management system, a structure element data has three main parts: 3D model, model attribute, and model archive. In the working of the master 3D bridge, the user can easily interact with the structure element because of object-oriented modelling and ID identification. Therefore, the 3D model inventory can be systematically accessed to extract and integrate data.

Figure 6 illustrates an example of the schematic information system of the bridge slab that can be standardized for information management of other structure's elements. The model attribute part contains general information in terms of the physical properties such as geometric, material properties, ID and location. It is the original data and extension part of the 3D model for network-level maintenance works. In addition, each element has its archive data list, which consists of all information for bridge inspection and maintenance requirements such as as-built information, inspection sheet, damage properties, repair manual and history. During the operation of the bridge, the data is accumulated in the archive data by the defined code system, which is described in the following section.

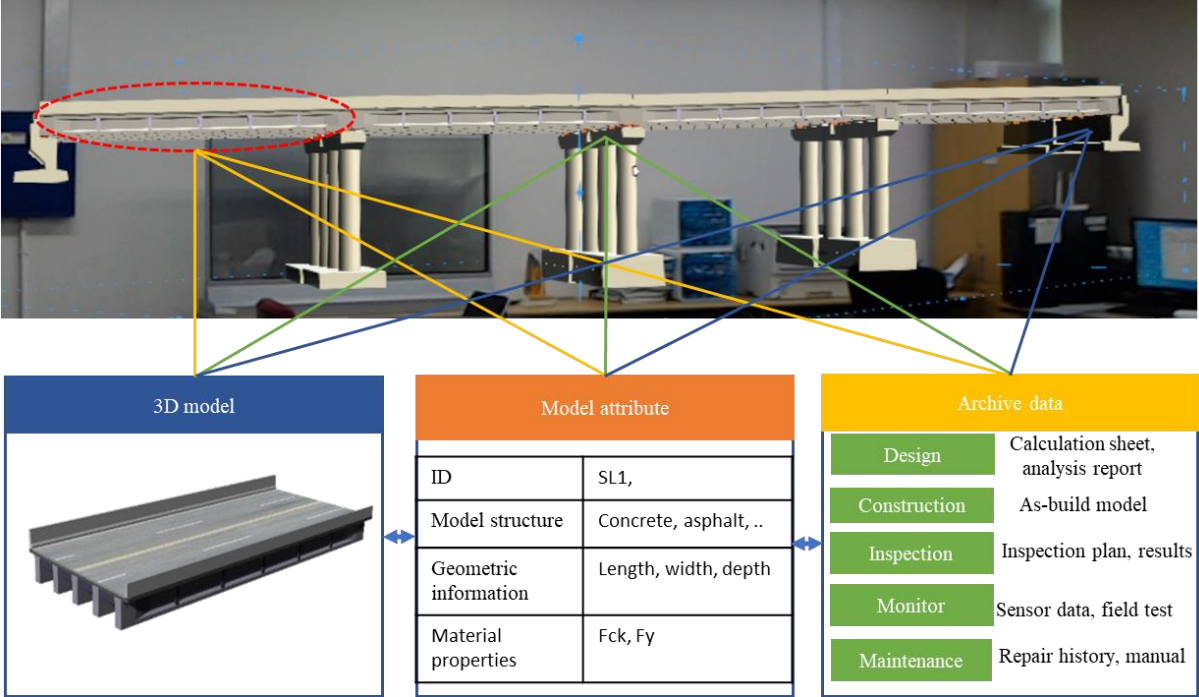


Fig. 6: The schematic information system

4.4 Documentation and damage code system

According to the guideline of bridge inspection and maintenance practices, the vast amount of inspected data from many sources has been accumulated during the service life. Nonetheless, the unclassified document is not available for inspectors who want to develop a deterioration model and monitor damage development based on the field inspection. In order to solve this problem, the document and damage code system was proposed, as shown in Figure 7 (Shim et al., 2019). For the document identification, class 01 is bridge name ID, and class 02 comply with the inventory system. Class 03 and 04 are the type and number of documents, respectively. From document to damage identification, class 05 and 06 are added to define damage and date of inspection. In the inspection documentation, the inspector uses the naming convention to quickly identify the damages with the history that is essential requirements for the maintenance task. Subsequently, the document of archive data can be linked to the model attribute document through the proposed code system and element ID. When this data system is used for whole bridges in a country, digital twin models for bridge members to express damage history can be built and utilized for future performance prediction.

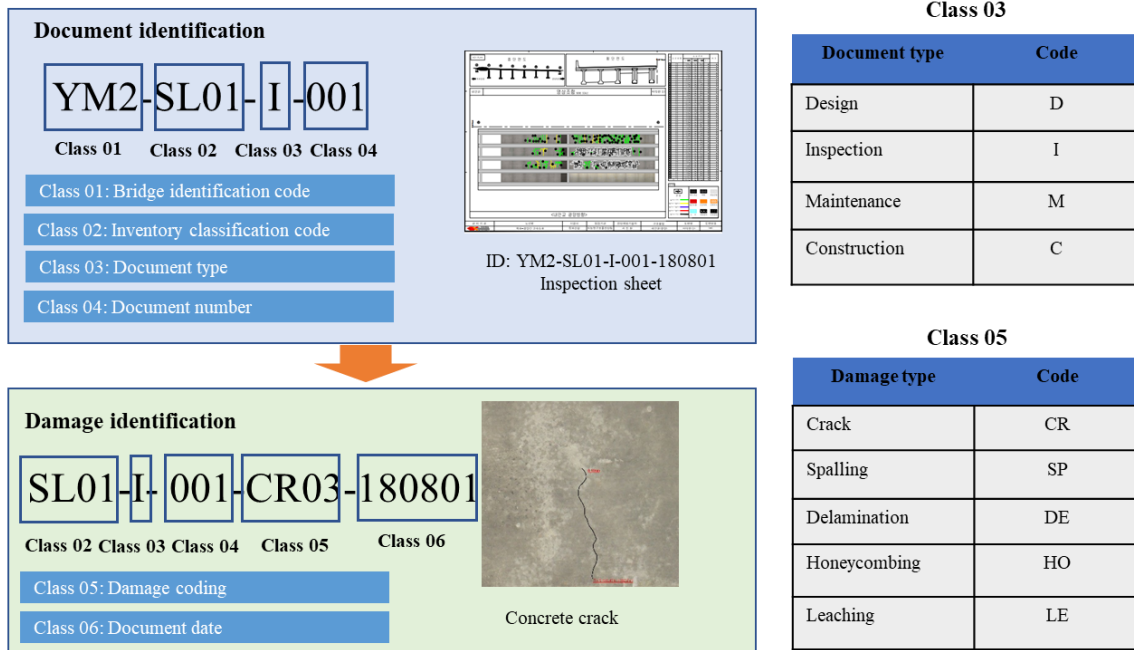


Fig. 7: Document and damage coding definition

5. DEVELOPMENT OF HOLOBRIDGE APPLICATION

5.1 Application development workflow

Figure 8 presents the development workflow of the Holobridge application. The workflow has three primary layers: BIM modelling development, application development and application compilation. The first layer is the development process of the 3D model of the asset using Revit and Dynamo from bridge geometric information. The model was then exported to an exchangeable 3D format such as IFC, FBX. After importing the 3D bridge model and database, the second layer is the design of the user interface and the development of functional modules uses C# programming language in Unity 2019.3. It contains modules of inspection, evaluation, cloud-based document and damage mapping. Inspection modules have several useful functions to visualize the inspection report and damage location along with damage profiles. The monitoring function has an algorithm to overlap damage data in the element model over time. The cloud-based platform allows the user to access documents from cloud storage. Evaluation module emphasizes to highlight the rating system from the color scheme. Consequently, maintenance actions can be planned. The last layer is application compiler, where the application is being deployed to HoloLens by Microsoft Visual Studio.

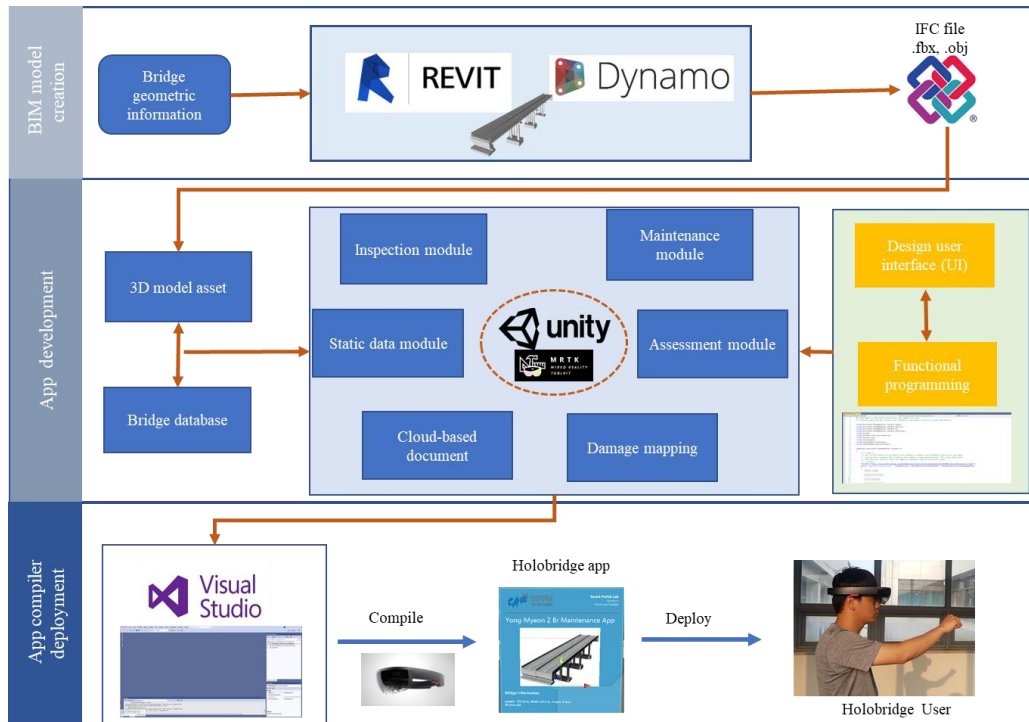


Fig. 8: The workflow of Holobridge application development

5.2 Bridge inspection module

Enhancing interpretation, analysis, evaluation and decision making are the main aims for visualizing damage records in MR space. The damage is visualized with the properties as location, dimension, history and causes. The bridge management agency categorizes the damage based on bridge structures itself, such as the damages of slab, abutment, pier and girder. The common types of bridge defects are crack, spalling, scaling, corrosion, leaching and delamination. Some defects can be detected by visual inspection (e.g. cracks, spalling, scaling), while others require an additional tool such as ground penetrating radar (GPR). The defect is extracted from the inspection report with properties and embedded into the BIM model. The federated model is a bridge inspection BIM Model with a defect database attached and located on bridge element surfaces. In the MR environment, the essential function of the Holobridge application to enhance and facilitate the bridge inspection work is the advance of the capability of integration damage data in the bridge BIM model. The application enables users to walk around the bridge and intuitively interact inspection database at defect locations.

On 3D model element surfaces, the damage can be managed by location-based algorithm. Each damage position is developed a function for observing and managing the damage propagation. The damage management process has two main steps, which are damage inspection and monitoring. Damage inspection is generally extraction of all relevant information for describing defects in terms of type, shape, dimension, and position from inspection reports. Besides, damage monitoring is the process of define condition state, cause and influence factors of damage propagation. Overall, six parameters are required for effectively managing one instance of damage: three to describe damage properties and three to assess and monitor the development of the damage. Figure 9 shows an example of crack visualization in the application.

The crack information contains ID, type, crack metric with width and length, condition state, cause, influence factors and crack history. Crack is one of the most common defects in concrete bridge structures. Crack is typically classified by cause and orientation as longitudinal, traverser crack. The crack width is categorized into hairline-minor, narrow-moderate and medium-severe, corresponding to condition state 1 to 3. During the operation phase, the factors affect crack formation and propagation caused by environmental conditions, design parameters, and maintenance works.

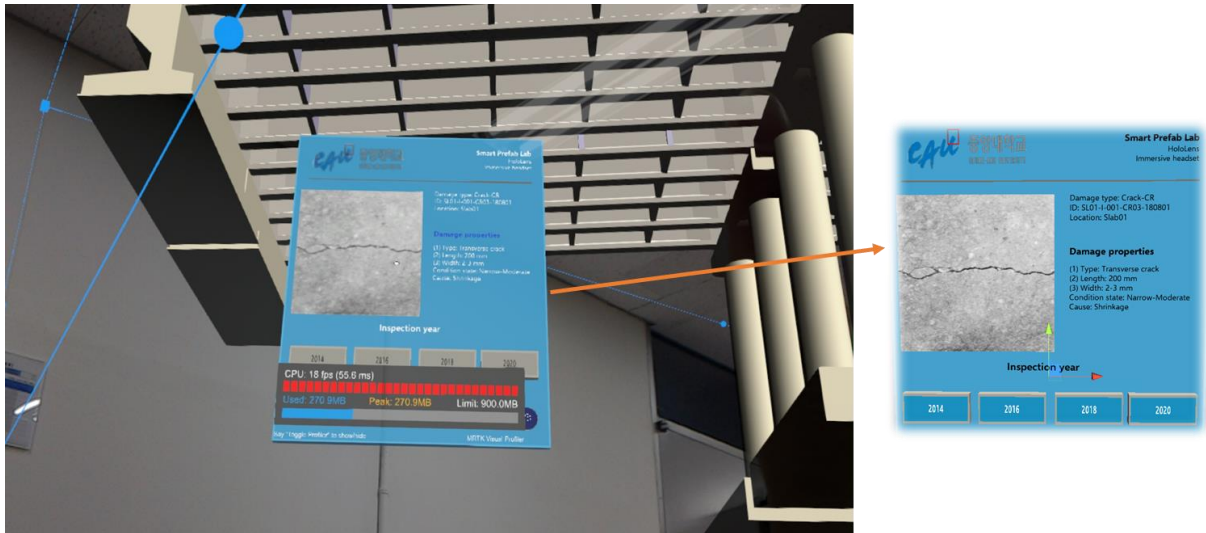


Fig. 9: Crack visualization

5.3 Damage mapping

The application develops the mapping function module for overlapping inspection photos with the 3D element model to provide the picture of an existing condition. The mapped model is a federated model to enrich information for inspection works. The element model is divided into observable surfaces, including top, lateral and bottom surface to map information. In the MR environment working, the inspector can check the damages information on the surface texture of the bridge elements model. Importantly, the inspection data can be stored in the element model during the operation phase. It is single-source information for monitoring damage development and developing a deterioration model for maintenance works. Figure 10 presents an example of mapping GPR data on the top surface of the slab to evaluate slab thickness, measurement of the thickness of the concrete cover, locating rebar. With this integration of GPR data for upper surface and damage records of the lower surface of the bridge slab, more reliable assessment can be supported.

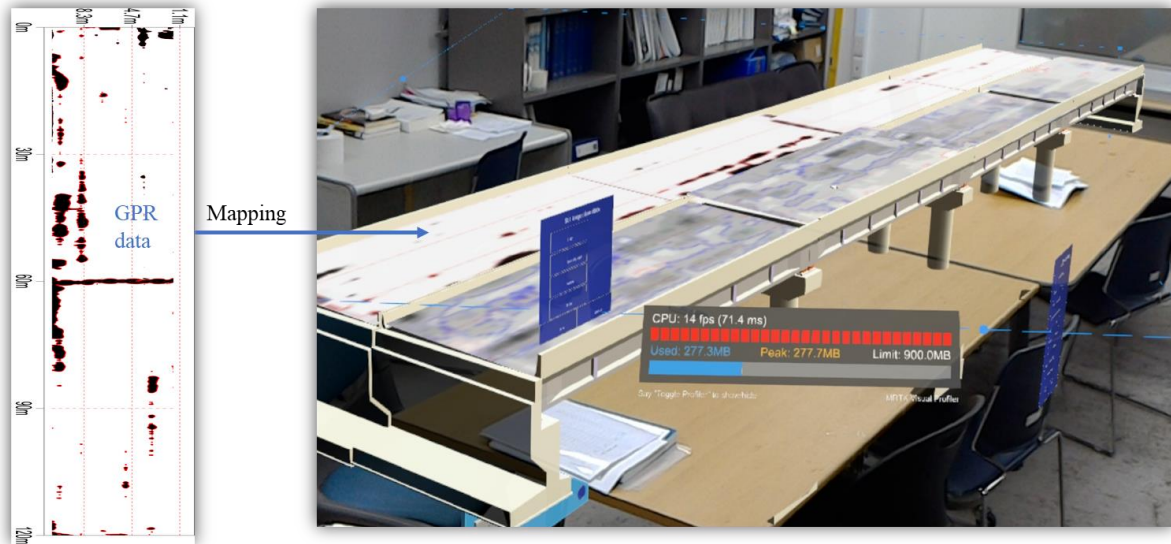


Fig. 10: GPR image mapping

Along with the BIM model and 2D-based inspection data, the 3D bridge scan model can be visualized in the application. With laser scanning and drone, the inspector can accurately and quickly capture the detailed geometric surface of bridge structures with damage information. 3D scan model is readily applicable to overlap with bridge BIM model to create a geometric digital twin model. The texture of the surface model can be used to measure the damage dimension. Figure 11 shows the result of visualizing a 3D bridge scan model in MR space. The overlapping between BIM and scan model enables the inspector to identify the defect location base on the reference BIM model.

Furthermore, the geometric digital twin model can be used for making a maintenance plan by the integration of the current condition of the 3D scan layer with the design information of the BIM model.

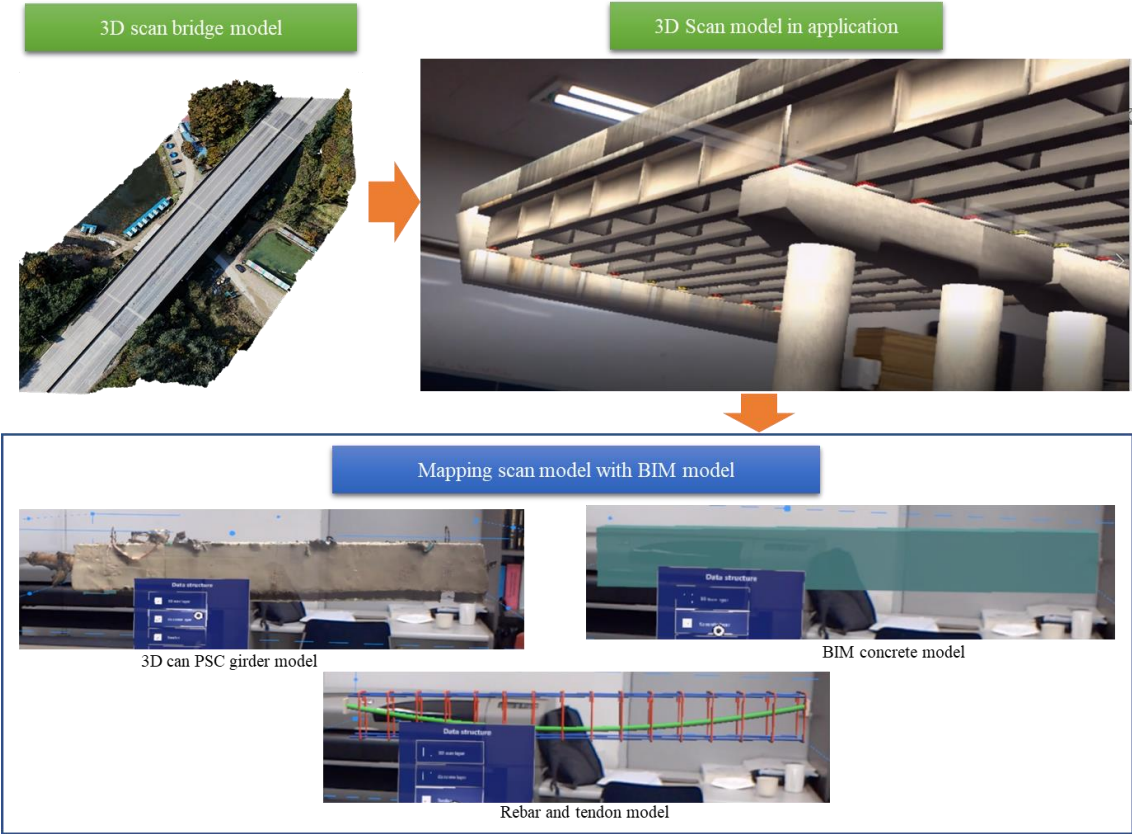


Fig. 11: Mapping scan module

5.4 Bridge evaluation and maintenance

Based on the results of the damage evaluation, bridge structures have been classified into groups of critical and non-critical. The condition rating of each element is defined by the deterioration model, including the field inspection result and the quantities analysis of damages history. The rating system has four condition states: good, fair, poor, severe, corresponding to blue, green, yellow and red color codes. In order to highlight the dangerous structures, the color condition rating module is developed. As shown in Figure 12, the bridge element model displays different colors. The pier column in yellow color shows the poor condition, and it needs to be repaired. The green structures are in good condition, and the red girder in severe condition requires to replace. As a result, the inspector can identify the structure currently in the dangerous condition to perform maintenance actions.

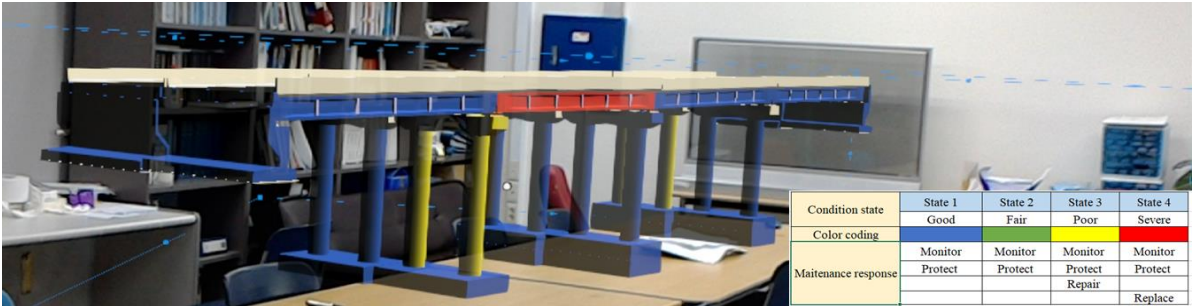


Fig. 12: Evaluation module

6. CONCLUSIONS

In this paper, a new approach for acquiring and compiling information on an MR-based application has been proposed. The concept of bridge inspection BIM model and geometric digital twin model is developed as the

theory-based for application development. The development process has two main parts: creating the database and programming of the functional module. The application database has three essential components: a well-organized foundation BIM model, inspection and maintenance information and data integration architecture. The functional module contains inspection, evaluation and damage mapping module. The conclusions from the pilot implementation are the following:

1. The inspection database can be systematically managed by using the 3D BIM model with attached data, and the proposed code system enables to monitor damage development and create a deterioration model efficiently.
2. In the MR space, the application improves information communication, visualization and collaboration in inspection and maintenance work because the data is more intuitively interactive in real-time simulation.
3. The inspection and maintenance tasks were significantly enhanced and facilitated by using a federated information model wherein the damage is mapped with a 3D foundation model during the whole life cycle of a bridge.

In future work, the research will be extended to develop a module for automatic damage detection, measurement and tracking. Through the system, digital twin models for bridge members can be developed.

7. ACKNOWLEDGMENTS

This research was supported by “Development of smart construction technology (20SMIP-B156007-01)” Research Program funded by the Ministry of Land, Infrastructure and Transport (MOLIT), South Korea.

8. REFERENCES

- Al-Shalabi, F.A., Turkan, Y. and Laflamme, S., 2015. BrIM implementation for documentation of bridge condition for inspection. In *Proceedings of the Canadian Society for Civil Engineering 5th International/11th Construction Specialty Conference, University of British Columbia, Vancouver, Canada*, 7-10.
- Demian, P. and Walters, D., 2014. The advantages of information management through building information modelling. *Construction Management and Economics*, 32(12), 1153-1165.
- Dunston, P.S. and Wang, X., 2005. Mixed reality-based visualization interfaces for architecture, engineering, and construction industry. *Journal of construction engineering and management*, 131(12), 1301-1309.
- Eastman, C.M., Eastman, C., Teicholz, P., Sacks, R. and Liston, K., 2011. *BIM handbook: A guide to building information modeling for owners, managers, designers, engineers and contractors*. John Wiley & Sons.
- Hamzeh, F., Abou-Ibrahim, H., Daou, A., Faloughi, M. and Kawwa, N., 2019. 3D visualization techniques in the AEC industry: the possible uses of holography. *Journal of Information Technology in Construction*, 239-255.
- Huang, Y., Shakya, S. and Zhu, L., 2019. Capabilities of Mixed Reality Applications for Architecture and Construction: A Comparative Review with HoloLens. In *Computing in Civil Engineering 2019: Visualization, Information Modeling, and Simulation*, American Society of Civil Engineers, 162-168.
- Hüthwohl, P., Brilakis, I., Borrmann, A. and Sacks, R., 2018. Integrating RC bridge defect information into BIM models. *American Society of Civil Engineers*.
- Karaaslan, E., Bagci, U. and Catbas, F.N., 2019. Artificial intelligence assisted infrastructure assessment using mixed reality systems. *Transportation Research Record*, 2673(12), 413-424.
- McGuire, B., Atadero, R., Clevenger, C. and Ozbek, M., 2016. Bridge information modeling for inspection and evaluation. *Journal of Bridge Engineering*.
- Moreu, F., Mleck, B., Vemuganti, S., Rogers, D., & Mascarenas, D., 2017: Augmented reality tools for enhanced structural inspection. *Structural Health Monitoring* .
- Omer, M., Margetts, L., Hadi Mosleh, M., Hewitt, S. and Parwaiz, M., 2019. Use of gaming technology to bring bridge inspection to the office. *Structure and Infrastructure Engineering*, 15(10), 1292-1307.
- Rokhsaritalemi, S., Sadeghi-Niaraki, A. and Choi, S.M., 2020. A Review on Mixed Reality: Current Trends, Challenges and Prospects. *Applied Sciences*.

Sacks, R., Kedar, A., Borrmann, A., Ma, L., Brilakis, I., Hüthwohl, P., Daum, S., Kattel, U., Yosef, R., Liebich, T. and Barutcu, B.E., 2018. SeeBridge as next generation bridge inspection: overview, information delivery manual and model view definition. *Automation in Construction*, 134-145.

Salamak, M. and Januszka, M., 2018. BrIM bridge inspections in the context of Industry 4.0 trends. *Maintenance, Safety, Risk Management and Life-Cycle Performance of Bridges*

Shim, C.S., Lee, K.M., Kang, L.S., Hwang, J. and Kim, Y., 2012. Three-dimensional information model-based bridge engineering in Korea. *Structural Engineering International*, 22(1), 8-13.

Shim, C.S., Kang, H.R. and Dang, N.S., 2019. Digital Twin Models for Maintenance of Cable-Supported Bridges. In *International Conference on Smart Infrastructure and Construction 2019 (ICSIC) Driving data-informed decision-making*, pp, 737-742.

Shim, C.S., Kang, H.R., Dang, N.S. and Lee, D.K., 2017. Development of BIM-based bridge maintenance system for cable-stayed bridges. *Smart Structures and Systems*, 20(6), 697-708.

VISION BASED CONSTRUCTION SITE MONITORING: A REVIEW FROM CONSTRUCTION MANAGEMENT POINT OF VIEW

Aritra Pal & Shang-Hsien Hsieh

Department of Civil Engineering, National Taiwan University, Taipei, Taiwan

ABSTRACT: Construction projects are facing challenges like low productivity, time & cost overrun, safety issues, etc. Lack of monitoring of site activities and resources is found to be one of the major causes of failure. Eradicating this cause with the conventional method needs domain expertise and high cost. The applications of computer vision (CV) based techniques are found as a cost-effective solution for remote project monitoring. Further, the deep-learning models have automated the monitoring process by learning from the images and videos captured at construction sites and thus eliminated the time consuming and labor-intensive part of monitoring. As this field is in its growing phase, the research directions are changing rapidly. So, a regular review of research trends is found obvious. To make use of the advancement of the CV research for the construction management application, ninety-two (92) SCI-indexed articles were reviewed through bibliometric, scientometric, and qualitative content analyses. Although some reviews have been conducted earlier, a critical review on the use of deep learning models for CV based site monitoring is novel in this study. Preliminary results show that Faster Region-based CNN (Fast R-CNN) for object detection, SORT for object tracking, and stacked hourglass network (HG) for pose estimation have been used mostly for effective monitoring of construction safety, resource productivity, structural health, and, construction waste. However, vision occlusion is posed as a major limitation in most of the studies.

KEYWORDS: Computer vision, Deep learning, Construction site monitoring, Construction management.

1. INTRODUCTION

To date, construction projects deploy a huge amount of human resources and manually operated machinery. So, the performance of those resources, as well as construction projects, are highly unpredictable. To ensure effective construction project management (CPM) by providing a productive and safe work site close monitoring is necessary. But, due to the large scale and scattered nature of construction sites, it is often difficult to monitor each corner of a project. Also, the effort of site monitoring sometimes demands high skill and high cost. The advancement of information technology (IT), and the affordable cost of computing and storing information has made the integration of IT in the construction industry natural. Researchers are constantly looking for a better solution to monitor projects remotely. Some research efforts have gone into discovering the effectiveness of pre-installed devices like Inertial Measurement Units (IMUs), Global Positioning System (GPS), Ultra-Wide Band (UWB), and Radio Frequency Identification (RFID) for construction workmen and equipment monitoring. Although these methods were found effective, the cost involved in installing and monitoring are restricting its wide range of use (Luo et al., 2019). Also, the installation of such devices on the human body or equipment body sometimes causes discomfort for the workers and thus it affects productivity (Kim et al., 2019b). On the other hand, computer vision (CV) based techniques are found to be a cost-effective option for non-invasive monitoring of construction projects remotely. CV is a multidisciplinary approach to acquire a reasonable understanding of the images and videos collected from the construction sites and then transfer that knowledge for effective decision making (Seo et al., 2015). CV based techniques have shown their capability to address many of the construction management challenges in their recent applications.

Although construction project monitoring through video data or image data is gaining popularity among the researchers, the manual analysis of those data is very time consuming and demands high domain expertise. To overcome this challenge, recent Convolution Neural Network (CNN) based deep-learning models are found to be very effective. The models have been extensively used for construction safety monitoring (Kim et al., 2019a; Zhang et al., 2019; Yan et al., 2019), productivity monitoring (Luo et al., 2018; Kim et al., 2019b; Lee & Park, 2019), waste management (Wang et al., 2019), structural health monitoring (Cheng and Wang, 2018) and so on. Common CV techniques such as object detection, object tracking, pose estimation, and action recognition are mainly used for these purposes. The construction workers, equipment, and activities were detected, tracked, or recognized for effective site monitoring. Although this field of research is gaining popularity among the researchers, it is still in its infancy stage. This indicates its potential for future research related to automated construction monitoring and management.

As the research outputs are becoming richer with the advancement of the embedded technologies, this field of research requires review after a regular interval. Although a few reviews have been already taken place in this domain, the most recent one (Zhang et al., 2020) has captured the data until March 2019, which is almost a year old. Also, most of the recent review articles have only addressed a specific application such as construction safety (Zhang et al., 2020; Seo et al., 2015; Fang et al., 2020a; Fang et al., 2020b). Few articles have only focused on scientometric analyses (Darko et al., 2020; Martinez et al., 2019; Zhong et al., 2019). The only review article related to performance monitoring of construction projects (Yang et al., 2015) was published five (5) years back. However, back in 2015, the use of deep learning (DL) models for vision-based site monitoring was not so prominent. It is worth mentioning that the very recent article published by Sherafat et al., (2020) conducted an extensive review of the automated activity recognition of construction workers and equipment. However, as recent vision-based applications are mostly using DL, an exclusive review of DL based CV techniques have the potential to contribute to the body of knowledge.

To bridge this gap, this study is aimed at reviewing the state-of-the-art applications of CV techniques and DL models for automatic site monitoring from the construction management point of view. The review is also looking into the research hotspots and authors' collaborations to understand better the progress and community building in this field. This is expected to help future researchers to connect with the research community and research subfields.

The organization of the paper is as follows. Section 2 describes the research method. Section 3 talks about various bibliometric and scientometric analyses. Qualitative content analyses consisting of the review of DL models are discussed in Section 4. Finally, Section 5 concludes the study.

2. RESEARCH METHOD

CV based construction site monitoring is a growing area of research in the built environment domain. Applications of such research are found beneficial for addressing many of the construction management problems. To understand the research evolution in this area, the current study has taken a systematic literature review approach through bibliometric, scientometric, and qualitative content analysis. The overall research method is divided into three (3) steps: data collection, data processing, and data analysis. During data collection, research articles published until April 2020 were searched and retrieved only from the major online database, Web of Science™ core collection, using a combination of words and phrases: “Computer Vision” AND Construction AND (Management OR Monitoring). The words and phrases were searched within the article's title, abstract, author keywords, and keywords plus. The selected database was chosen for its varied collection of high-quality journals related to construction, engineering, and management (Zhong et al., 2019). The search result mined 92 Science Citation Indexed (SCI) and Social Science Citation Indexed (SSCI) journal articles. In the data processing stage, the articles written in English were selected and reviewed for its relatedness with the theme of this research. Finally, sixty-one (61) articles published across 12 high-quality journals were selected for further data analysis.

Data collected from the selected literature were examined using bibliometric, scientometric, and content analyses (Martinez et al., 2019). During bibliometric analysis, the selected articles were organized based on their year of publication and the journals with the highest number of publications in this research theme were identified. Scientometric analyses helped in identifying the research hotspots by analyzing the co-occurrence and the evolution of the author's suggested keywords. Visualization of the author's network map was used for searching the most productive university and the country in this research field. VOSviewer, a software tool, was used for visualizing the scientometric data effectively. Further, qualitative content analyses highlighted the research trends. It is observed that, with the advancement of CV technology, the use of DL models is gaining importance among the researchers. So, the content analysis of this study has mainly focused on reviewing the DL models in the context of construction management and construction site monitoring. First, the articles were classified based on construction monitoring and management applications like safety, productivity, progress monitoring, etc. Next, the information about CV techniques (object detection, tracking, etc) and related DL models in the context of those applications was discussed. Finally, the models were compared based on usage statistics and performance as highlighted in various previous studies.

3. BIBLIOMETRIC & SCIENTOMETRIC ANALYSIS

The publishing of the research articles related to CV applications in construction monitoring started from the year 2009. However, thirty-two (32) out of sixty-one (61) selected articles, (more than 50%) were published recently from the year 2018 to April 2020. The advancement of technology, availability of high-resolution cameras, greater

storage space, and accessibility of the Internet has smoothed the path for CV related research for the construction industry (Yang et al., 2015). It has been observed that 90% of the selected articles were published in six (6) top-ranked journals. “Automation in Construction”, “Journal of Computing in Civil Engineering” and “Advanced Engineering Informatics” are the top three (3) journals in terms of the number of publications in this research field. Among them, “Automation in Construction” is leading with twenty-six (26) articles (43%). Figure 1 shows both year-wise and journal wise publication statistics. Journals with two or more publications are presented in this figure.

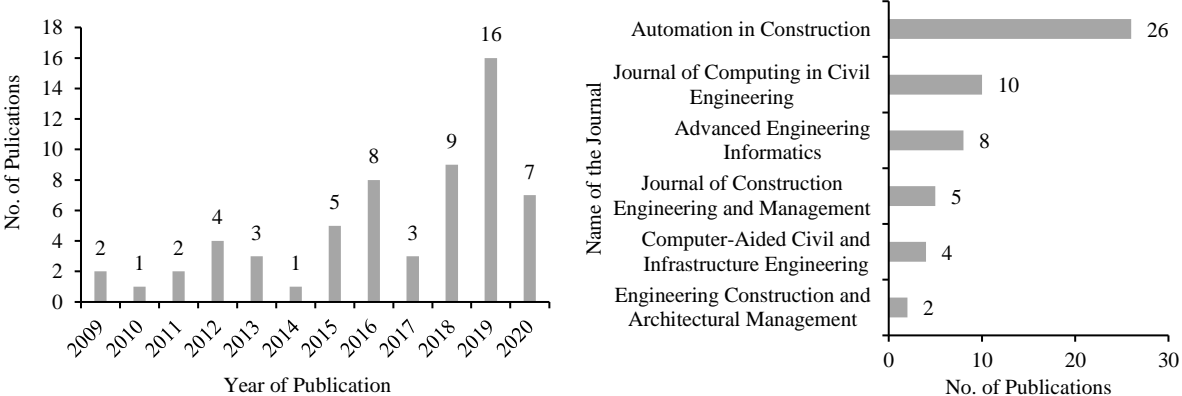


Fig. 1: Year-wise number of publications (left) and journals with more than two publications (right)

For scientometric analyses, visualization of the data is very important. A software tool like VOSviewer has eased that by providing the features of network map construction. In this study, VOSviewer is used for analyzing the keywords co-occurrence and evolution. Keywords are the concise representation of the document content. Co-occurrence analysis of these keywords provides a better understanding of the research hotspots in a particular field of study. On the other hand, the evolution analysis can help in identifying the most recent and relevant research direction. The articles retrieved from the Web of Science database contains two types of keywords: author keywords and keywords plus. To get the idea about the research hotspots from the researcher's point of view, the authors suggested keywords were only selected. Out of 205 author keywords, fourteen (14) met the criteria of having occurrence frequency more than 3. Figure 2 shows the co-occurrence mapping of the keywords.

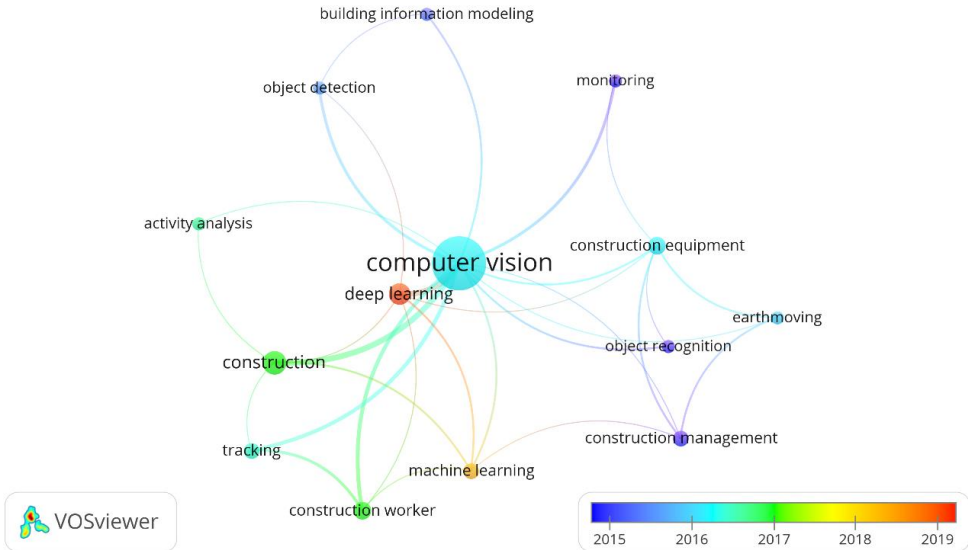


Fig. 2: Co-occurrence mapping and evolution analysis of keywords.

The size of the circles represents the weightage of occurrence the line between the circles represents the link between different keywords, the thickness of the lines represents the strength of the links, and the rainbow color represents the temporal scale with red being the most recent. It can be obviously seen that “computer vision” is the most frequently used keywords as the research theme is centered around the same. However, “deep learning”, “construction”, “tracking”, “construction worker” are found to be some of the closely related keywords. The

evolution of keywords in Figure 2 clearly shows that “deep learning” and “machine learning” are the two most recent keywords in this field. The strong link of “deep learning” with other keywords and its most recent applications indicates a huge possibility for future research.

To understand the progress of the research, analyzing author collaboration is another important direction. Collaboration can improve knowledge and help to achieve the same goal of the research community. In this study, the research collaboration among the authors was identified by analyzing the co-authorship statistics through the VOSviewer tool. The analysis was able to provide a better insight into the participating author’s organization and the country. Fifty-nine (59) organizations from twelve (12) countries were found taking part in this research area. Figure 3 shows the heat map of the collaborating author’s countries. China, Hong Kong, USA, Australia, South Korea, England, and Canada are the countries where vision based construction monitoring research has gained high priority. A close collaboration was observed on one side among the USA, Korean and Canadian researchers, on the other side among the researchers from China, Hong Kong, and Australia.

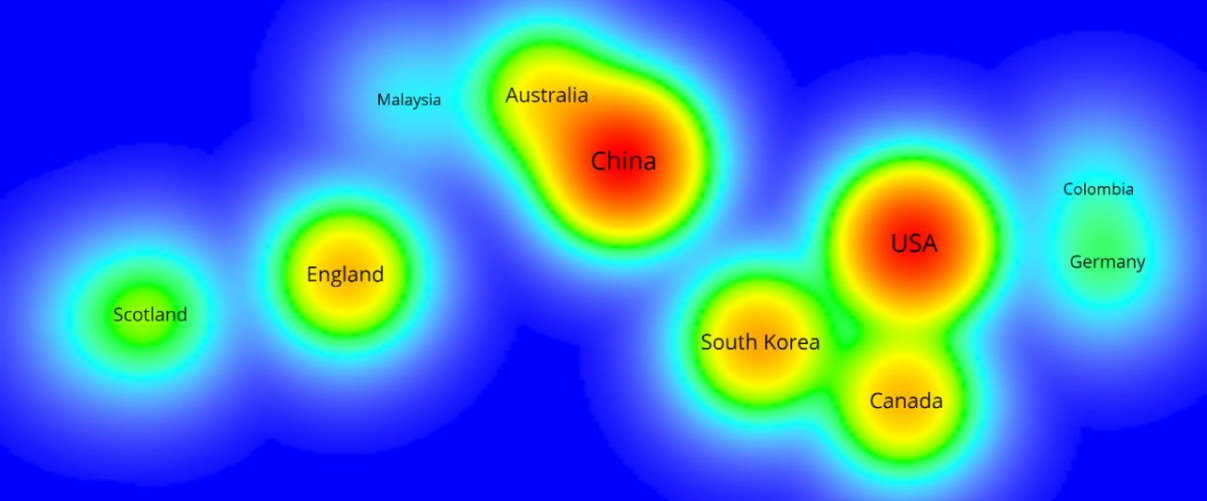


Fig. 3: A heat map showing the countries of the collaborating authors.

Performance analysis of the research organizations reveals that “Hong Kong Polytechnic University” from Hong Kong, “Huazhong University of Science and Technology” from China, “University of Illinois” from the USA, “Yonsei University” from South Korea, “Curtin University” from Australia, “University of Cambridge” from the UK, and The “University of Toronto” from Canada have taken the lead role from their respective countries. Also, it was observed that there exist two highly productive research groups in this domain. Figure 4 shows the visual representation of network maps of those research groups. Different colors in the map represent different clusters and the lines represent links between items. Although, “Hong Kong Polytechnic University” and “Huazhong University of Science and Technology” have published the highest number of articles, articles by The “University of Illinois” and “University of Michigan” were cited most frequently. Table 1 represents the list of research organizations with the number of published documents and citations details. Only organizations with more than two publications are presented in this table.

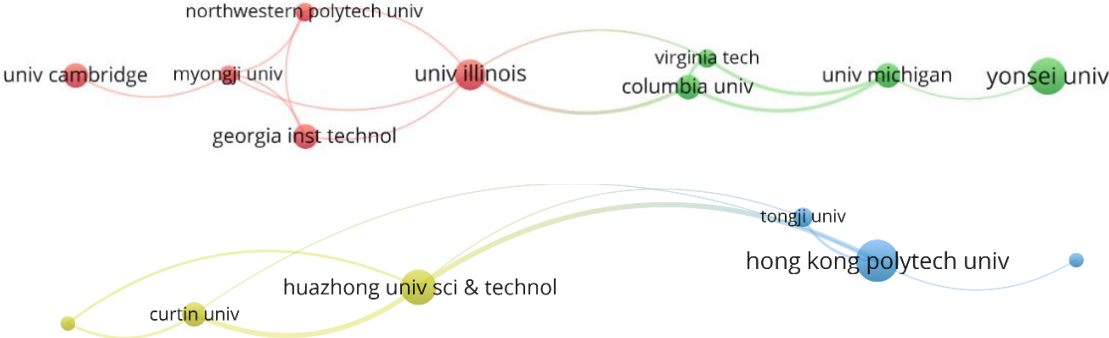


Fig. 4: Network Map of the two most productive research groups.

Table 1: List of universities with more than two publications

Research Organization	Docs.	Citation	Research Organization	Docs.	Citation
Hong Kong Polytechnic University	9	12	Columbia University	4	229
Huazhong University of Science & Technology	7	26	University of Cambridge	4	41
Yonsei University	6	145	Virginia Tech	3	216
University of Illinois	5	251	Northwestern Polytechnical University	3	102
Curtin University	4	19	Myongji University	3	97
University of Michigan	4	240	University of Toronto	3	153
Georgia Institute of Technology	4	183	Tongji University	3	2

4. QUALITATIVE CONTENT ANALYSIS

4.1 Overview of computer vision application for construction management

CV is a subfield of artificial intelligence that trains computers to understand and interpret images and video data. The training makes machines capable of detecting objects, classifying objects, and then reacting to what they ‘see’ (Sonka et al., 1993). This interesting feature of CV has made it popular among researchers for solving many engineering problems. Researchers from the field of Civil or Construction Engineering also got fascinated with this. The applications of CV in Civil Engineering has many directions. However, this study has focused on CV applications for better construction project management. The selected papers were of two categories: papers related to preparatory works for CV and papers related to CV applications.

Any application of computer vision needs to go through some preparatory works such as data collection, annotation, and model training (Luo et al., 2020). These preparatory works demand a lot of human effort, time, and skills (Gong and Caldas, 2010). Therefore, several researchers have taken initiatives to ease the time consuming and labor-intensive parts of the preparatory works. The surveillance camera system has become an essential requirement for adopting a CV based site monitoring system in the construction project. However, the optimized placement of cameras is a challenging task. To address this, Yang et al. (2018) tried to solve a multi-objective optimization problem for maximizing the coverage area of the surveillance system with minimum cost. An annotated dataset consisting of image and video data is a vital requirement for training the CV models. Limitation of the publicly available datasets for the construction projects sometimes hinders the wide application of CV techniques. So, some researchers have tried to construct image datasets with images from construction sites (Yang et al., 2016; Wu et al., 2019) or by using synthetic images (Kim & Kim, 2018; Rahimian et al., 2020; Soltani et al., 2016). Web crawling is a method for automatically searching the Internet for retrieving the required information. Arabi et al. (2020) used such technology to gather images of specific construction equipment. Annotation of images according to ground truth is one of the most time taking task in the whole process. Liu & Golparvar-Fard (2015) proposed an innovative idea of crowdsourcing construction activity analysis for making the annotation process less burdensome using Amazon Mechanical Turk (AMT). For training the DL models, a huge number of images are required. But, often it is very difficult to find and annotate a dataset with a large number of images. Data augmentation is a feasible solution to this problem. The number of images in a given dataset can be increased by rotating, flipping, translating, or converting the colors of the available images. Although the human eye can recognize augmented images as the same image, for computers those are completely different image because of the change in their pixel location or the RGB values (Cheng & Wang, 2018; Kim et al., 2019b; Luo et al., 2020; Luo et al., 2018; Kolar et al., 2018; Fang et al., 2019; Wei et al., 2019; Yan et al., 2020).

Fifty-two (52) articles from the selected literature group (approximately 85%) have highlighted various applications of CV based monitoring methods in construction projects. Out of all the applications, monitoring of a safe work environment, and monitoring of resources for ensuring desired productivity have got the most importance. The prominence of site management applications and BIM integrated CV based progress monitoring are also observed during the study. Few research papers have also investigated the applications of CV for structural health monitoring and construction waste management.

Ensuring safety at a construction site is a major challenge because of the dynamic nature of the construction projects. Mistakes can even lead to fatal accidents. Therefore, it comes with no surprise that CV applications for monitoring worksite safety got the highest importance among the researchers with fourteen (14) out of fifty-two (52) articles addressing the safety issues. The applications found from this review are of two kinds: preventing unsafe conditions and preventing unsafe acts. Accidents from the collision (Luo et al., 2020), struck by (Yan et al. 2020), or fall from height (Fang et al., 2019) can be avoided if the system can identify the worker or object in

threat and subsequently advise for the prevention of the unsafe condition (Kolar et al., 2018). Similarly, workers are also responsible for maintaining their safety by avoiding unsafe acts. In this regard, CV based systems can identify unsafe acts (Fang et al., 2019) and make the offender aware of them to prevent accidents.

The construction industry largely depends on human resources and human-operated machines for generating the output. Productive utilization of resources is another major problem for this sector. The advancement of vision-based techniques is promoting the remote monitoring of resources for ensuring desired productivity. 23% of the application articles in this review are focusing on addressing construction productivity issues. Cycle time monitoring (Kim et al., 2019b), pose estimation (Azar et al., 2013), activity recognition (Luo et al., 2018), quantification of performed tasks (Bügler et al., 2017) were some of the effective CV applications for this purpose.

Construction sites possess a more complex and dynamic environment. Site management is another application which was largely benefitted from the CV based techniques. Some of the common issues for CV based construction site management are occlusion, background clutter, congestions, scene illuminations, etc (Konstantinou et al., 2019). At a construction site, instead of dealing with a single object at a time, Luo et al. (2019) addressed multiple objects at the same time. Tracking of objects throughout the site premises sometimes needs to use stereovision and multiple cameras (Konstantinou and Brilakis, 2018). The integration of the nD BIM model and the photographs taken from the real construction site is found to be one of the effective ways to monitor project progress. Comparison of as planned BIM and automatic 3D reconstructed as-built BIM provides a better insight into the progress of the project (Golparvar-Fard et al., 2015; Soga & Schooling, 2016).

The application of CV techniques in post-construction asset management is also prominent. Structural health monitoring and maintenance requirement assessment of public infrastructure (Cheng and Wang, 2018) are some of the key applications. The use of robots with a computer vision made human life easier. Such robots have eliminated risky jobs such as steel structures and bridges inspection (La et al., 2019). Also, the application of similar robots was observed for the detection and removal of construction waste such as screws and nails (Wang et al., 2019).

In the next section, the most popular and recent use of DL models is discussed in the context of the aforementioned applications.

4.2 Discussions on deep-learning models

With the advancement of computer CV hardware technology, various CV software methods have also been developed and enhanced from time to time. Researchers have used different methods for different purposes of computer vision. These methods are useful for addressing many computer vision techniques such as object detection, object tracking, pose estimation, action, or activity recognition. A list of methods found in the selected literature with their starting year of publication and the year with the most publications is shown in Table 2. It is observed that DL using Convolutional Neural network (CNN) is the most recent method. Despite being the newest, this method has got the most attention among the researchers. This method was found present in 32% of the papers. Another method that was most popular among the researchers before the advent of the DL-based methods was the Histogram of Gradient (HOG) method. Methods like Haar-like feature, HOG, and background subtraction method were known for its feature extraction properties. While Haar and HOG dealt with shape features, Mixture of Gaussians based background subtraction or foreground detection methods were useful for spatial-temporal features (Park and Brilakis, 2012). However, these feature descriptors need to be designed by experts with handcrafted features. To make this process more automatic, DL methods have been developed to learn and extract complex features from the raw data (Lecun et al., 2015). The most common DL method for dealing with images is CNN. The main difference between a CNN and ANN is the multilayer data abstraction and learning (Lecun et al. 2015). The applications of different DL models for various computer vision techniques are described in the rest of this section.

Table 2: Computer Vision Methods with starting and average year of publications

Computer Vision Methods	Starting Year of Publication	The year with the most publications
Haar-like Features	2009	2010
Artificial Neural Network (ANN)	2012	2012
Histogram of Gradient (HOG)	2012	2016
Background Subtraction/ Mixture of Gaussians (MoG)	2016	2017
Deep Learning/ Convolutional Neural Network (CNN)	2018	2019

4.2.1 Object detection

Object detection is the most fundamental technique in computer vision applications. It helps in identifying a specific object in a set of images using its semantic or location features. Also, it helps in initiating other CV techniques such as object tracking, pose estimation, etc. Recently CNN based object detection is found in many construction management applications. Faster Region-based Convolutional Neural Network (Faster R-CNN) got the highest popularity among the researchers because of its high accuracy level (Fang et al., 2019). In this review, the use of Faster-R-CNN was observed for detecting construction workers and equipment to prevent struck-by accidents (Yan et al., 2019, 2020), construction waste detection & recycling (Wang et al., 2019), and sewer pipe defect detection for structural health monitoring (Cheng and Wang, 2018). Single Shot MultiBox Detector (SSD) is another popular method for object detection. Multiple equipment detection (Arabi et al., 2020), construction workers' hard hat detection (Wu et al., 2019), and other Personal Protective Equipment (PPE) detection (Fang et al., 2018) were some of the applications of SSD found during the study. The You Only Look Once – version 3 (YOLOv3) method for object detection is generally known for its lesser computational cost and real-time applications (Kim et al. 2019a). Detection of construction workers and equipment in UAV videos for preventing struck-by accidents using YOLOv3 was tried by Kim et al. (2019a). The application of the same method in site management was observed in the study of Luo et al. (2019). The use of Mask Region-based Convolutional Neural Network (Mask R-CNN) was found in construction workers, structural support (Fang et al., 2019), and vehicle detection for construction safety and structural health monitoring (Xia et al., 2019) applications. Region-based Fully Convolutional Networks (R-FCN) and FuseNet models were found in the applications of earthmoving equipment productivity assessment (Kim et al. 2019b) and progress monitoring through 4D BIM respectively (Rahimian et al., 2020). Kolar et al. (2018) used a customized CNN model based on Visual Geometry Group (VGG16) for safety guardrail detection at construction sites.

4.2.2 Object tracking

Object tracking is the most useful technique in computer vision to automatically detect the position of the object spatiotemporally. This method possesses a huge potential application for dynamic construction site monitoring (Luo et al., 2019). It also helps in finding the trajectory of movement of a specific object or multiple objects and helps in predicting its future positions (Xia et al., 2019). However, the 'cold start' was found to be a major limitation of earlier tracking methods as every time a user needs to define the object of interest to start the tracking. As object detection has been advanced, the automatic tracking-by-detection has overcome this challenge (Luo et al., 2019). Once an object is detected in one frame, the same can be tracked through various frames. Also, the process of multiple object tracking has become easy. Simple Online and Real-time Tracking (SORT) is one of such kind of tracking method. Relatively low training costs and high processing speed make it useful for real-time applications. The SORT method detects objects in the current frame by considering their movement direction and speed in the previous frame (Fang et al., 2018). The application of the SORT tracking method was found in workspace monitoring by tracking multiple workers and equipment (Luo et al., 2019), also in the tracking of workers to prevent falls from height accidents (Fang et al., 2018). Another method called Coordinate Transformation was used by Xia et al. (2019) to track the vehicle movement in the context of structural health monitoring of bridges.

4.2.3 Pose estimation

Posture estimation or pose estimation of equipment and workers at the construction site can provide relevant information for construction site monitoring. The pose estimation generally takes place by estimating the 3D joint

positions of skeletal structures of the object. Stacked Hourglass Network (HG) was found to be the most popular DL model for pose estimation. The same was used for equipment pose estimation to know about the full working space of equipment and avoid collision accidents (Luo et al., 2020). For nonintrusive joint estimation of workers for assessment of joint fatigue during construction activity, Yu et al. (2019a) and Yu et al. (2019b) also used HG network models. R3DJP, a 3D pose estimation model was used by Yan et al. (2019) to correctly estimate worker's body joints to avoid the risk of struck-by accidents. Another popular human pose estimation model called Cascade Pyramid Network (CPN) was used by Luo et al. (2020) in their study of equipment pose estimation for the performance comparison with HG network models.

4.2.4 Action recognition

Worker's action recognition or activity recognition is another useful technique for managing construction sites. Identifying equipment or worker's action through surveillance cameras at a construction site can provide a lot of information related to productivity, progress monitoring, safety, security, etc. Earlier methods were unable to resolve problems of activity recognition in a complex environment, group activities, etc. (Luo et al., 2018). With the advancement of CNN, Luo et al. (2018) used deep three-stream CNN based on the VGG-16 model for automatic activity recognition during reinforcement work at a construction site. This was useful for productivity assessment. Luo et al. (2019) used the 3DResNeXT model for activity recognition of construction workers at a dynamic workspace. The said model was a 3D CNN based model. The overall video clips were segmented into discrete clips for effective activity recognition.

The details of all models for object detection, tracking, pose estimation, and action recognition and their associated application in construction management have been summarised in Table 3.

Table 3: DL models used in various CV techniques

DL Models	Target Object	Applications	References
Object Detection			
Faster RCNN	Workers, Equipment, Nails & Screws, Sewer pipes	Construction Safety, Waste Management, Structural Health Monitoring	(Yan et al. 2020), (Yan et al. 2019), (Wang et al. 2019), (Cheng and Wang 2018)
SSD	Workers, Equipment	Site Management, Construction Safety	(Arabi et al. 2020), (Wu et al. 2019), (Luo et al., 2018)
YOLO V3	Workers, Equipment	Site Management, Construction Safety	(Luo et al., 2019), (Kim et al. 2019a)
Mask RCNN	Workers, Structural supports, Vehicle	Construction Safety, Structural Health Monitoring	(Xia et al. 2019), (Fang et al., 2019)
R-FCN	Equipment	Construction Productivity	(Kim et al. 2019b)
FuseNet	BIM elements	Progress Monitoring	(Rahimian et al., 2020)
Anonymous CNN	Workers, Guard Rails	Construction Safety	(Wei et al. 2019), (Kolar et al. 2018)
Object Tracking			
SORT	Workers, Equipment	Construction Safety, Site Management	(Fang et al., 2019), (Luo et al., 2019)
Coordinate Transformation	Vehicle	Structural Health Monitoring	(Xia et al. 2019)
Pose Estimation			
HG	Workers, Equipment	Construction Safety	(Luo et al., 2020), (Yu et al. 2019b), (Yu et al. 2019a)
CPN	Equipment	Construction Safety	(Luo et al., 2020)
R3DJP	Workers	Construction Safety	(Yan et al. 2019)
Activity Recognition			
3D ResNeXT	Workers, Equipment	Site Management	(Luo et al., 2019)
Deep three-stream CNN	Workers	Construction Productivity	(Luo et al., 2018)

4.3 Comparison of existing models

Although the selection of DL models is very specific to the need of the application, some researchers have taken an effort to test popular DL models into their applications and compare their performance. Table 4 shows the comparative results. Arabi et al. (2020) compared Faster R-CNN and SSD for multiple construction equipment detections and found better performance in the case of SSD. Similarly, the study of Luo et al. (2019) recorded better performance of the YOLOv3 model than Faster R CNN for multiple workers and equipment detection. CNN with VGG-16 and MLP outperformed CNN with a support vector machine (SVM) for safety guardrail detection applications (Kolar et al., 2018). While comparing the result of full-body pose estimation of excavators, Luo et al. (2020) found that the ensemble model of HG-CPN has shown better precision.

Table 4: Comparison of existing DL models

Application	Model Details	Precision	Reference
Multiple Equipment Detection	Faster RCNN-Inspection ResNet V2 Combination	75.71%	(Arabi et al. 2020)
	SSD Inspection ResNet V2 Combination	91.00%	
Multiple Equipment & Worker Detection	YOLOv3 Darknet 53	75.10%	(Luo et al., 2019)
	Faster RCNN ResNet -50	69.70%	
Safety Guardrail Detection	CNN with SVM	78.30%	(Kolar et al. 2018)
	CNN with VGG-16 & MLP (Multi Layer Perception Net)	97.00%	
Full body pose estimation of Excavators	Stacked Hourglass Network (HG)	92.56%	(Luo et al., 2020)
	Cascaded Pyramid Network (CPN)	93.17%	
	Ensemble Model (Integration of HG-CPN)	93.43%	

5. CONCLUSION

This study has reviewed computer vision applications in construction site monitoring with a special focus on construction management issues. For this purpose, high-quality SCI/SSCI-indexed articles were selected. It was observed that although many review papers have been published recently, very few have addressed DL-based site monitoring techniques. The bibliometric and scientometric analyses reveal that most of the papers related to deep learning and machine learning have been published very recently (i.e. starting from 2018). The co-authorship analyses highlight that USA and Hong Kong are most productive in this domain. Although the universities from Hong Kong and China have published the largest number of papers, research articles from the US universities are cited most frequently. The qualitative content analysis has divided the research efforts into two areas, namely preparatory works for CV and CV applications. The CV applications (85% of the articles reviewed) got the most attention from the researchers. The popular CV applications in the construction management domain found in this study are construction safety, productivity, progress monitoring, site management, waste management, and structural health monitoring. In these applications, the use of CV techniques, such as object detection, tracking, pose estimation, and activity recognition was observed frequently. A DL model based on a convolutional neural network is the most recent advancement in this domain. It has made the feature extraction automatic, instead of user-defined handcrafted. Different DL models have been used by researchers for different CV techniques. Among them, Faster RCNN for object detection, SORT for object tracking, Stacked Hourglass Network for pose estimation, and 3D CNN for activity recognition was found to be the most popular one among the researchers. Some researchers have compared different model performances during their studies and the results can help in the future selection of DL models for various applications. Although this field of study is growing very fast, monitoring complex, dynamic construction site still requires advanced research efforts for managing issues related to vision occlusion, background clutter, congestion, low illumination, multi-camera multi-object tracking without cold start, and the limitation of the publicly available datasets for the construction projects.

6. REFERENCES

Arabi, S., Haghghat, A., and Sharma, A. (2020). "A deep-learning-based computer vision solution for construction vehicle detection." *Computer-Aided Civil and Infrastructure Engineering*, 1–15.

- Bügler, M., Borrmann, A., Ogunmakin, G., Vela, P. A., and Teizer, J. (2017). "Fusion of Photogrammetry and Video Analysis for Productivity Assessment of Earthwork Processes." *Computer-Aided Civil and Infrastructure Engineering*, 32(2), 107–123.
- Cheng, J. C. P., and Wang, M. (2018). "Automated detection of sewer pipe defects in closed-circuit television images using deep learning techniques." *Automation in Construction*, Elsevier, 95(August), 155–171.
- Darko, A., Chan, A. P. C., Adabre, M. A., Edwards, D. J., Hosseini, M. R., and Ameyaw, E. E. (2020). "Artificial intelligence in the AEC industry: Scientometric analysis and visualization of research activities." *Automation in Construction*, Elsevier, 112(May 2019), 103081.
- Fang, Q., Li, H., Luo, X., Ding, L., Luo, H., and Li, C. (2018). "Computer vision aided inspection on falling prevention measures for steepjacks in an aerial environment." *Automation in Construction*, Elsevier, 93(December 2017), 148–164.
- Fang, W., Ding, L., Love, P. E. D., Luo, H., Li, H., Peña-Mora, F., Zhong, B., and Zhou, C. (2020a). "Computer vision applications in construction safety assurance." *Automation in Construction*, Elsevier, 110(February 2019), 103013.
- Fang, W., Love, P. E. D., Luo, H., and Ding, L. (2020b). "Computer vision for behaviour-based safety in construction: A review and future directions." *Advanced Engineering Informatics*, Elsevier, 43(August 2019), 100980.
- Fang, W., Zhong, B., Zhao, N., Love, P. E. D., Luo, H., Xue, J., and Xu, S. (2019). "A deep learning-based approach for mitigating falls from height with computer vision: Convolutional neural network." *Advanced Engineering Informatics*, Elsevier, 39(December 2018), 170–177.
- Golparvar-Fard, M., Peña-Mora, F., and Savarese, S. (2015). "Automated progress monitoring using unordered daily construction photographs and IFC-based building information models." *Journal of Computing in Civil Engineering*, 29(1), 1–19.
- Gong, J., and Caldas, C. H. (2010). "Computer vision-based video interpretation model for automated productivity analysis of construction operations." *Journal of Computing in Civil Engineering*, 24(3), 252–263.
- Kim, D., Liu, M., Lee, S. H., and Kamat, V. R. (2019a). "Remote proximity monitoring between mobile construction resources using camera-mounted UAVs." *Automation in Construction*, Elsevier, 99(April 2018), 168–182.
- Kim, H., Ham, Y., Kim, W., Park, S., and Kim, H. (2019b). "Vision-based nonintrusive context documentation for earthmoving productivity simulation." *Automation in Construction*, Elsevier, 102(February), 135–147.
- Kim, H., and Kim, H. (2018). "3D reconstruction of a concrete mixer truck for training object detectors." *Automation in Construction*, Elsevier, 88(November 2017), 23–30.
- Kolar, Z., Chen, H., and Luo, X. (2018). "Transfer learning and deep convolutional neural networks for safety guardrail detection in 2D images." *Automation in Construction*, Elsevier, 89(February), 58–70.
- Konstantinou, E., and Brilakis, I. (2018). "Matching Construction Workers across Views for Automated 3D Vision Tracking On-Site." *Journal of Construction Engineering and Management*, 144(7), 1–12.
- Konstantinou, E., Lasenby, J., and Brilakis, I. (2019). "Adaptive computer vision-based 2D tracking of workers in complex environments." *Automation in Construction*, Elsevier, 103(February), 168–184.
- La, H. M., Dinh, T. H., Pham, N. H., Ha, Q. P., and Pham, A. Q. (2019). "Automated robotic monitoring and inspection of steel structures and bridges." *Robotica*, 37(5), 947–967.
- Lecun, Y., Bengio, Y., and Hinton, G. (2015). "Deep learning." *Nature*, 521(7553), 436–444.
- Lee, Y. J., and Park, M. W. (2019). "3D tracking of multiple onsite workers based on stereo vision." *Automation in Construction*, Elsevier, 98(August 2018), 146–159.
- Liu, K., and Golparvar-Fard, M. (2015). "Crowdsourcing Construction Activity Analysis from Jobsite Video

- Streams.” *Journal of Construction Engineering and Management*, 141(11), 1–19.
- Luo, H., Wang, M., Wong, P. K. Y., and Cheng, J. C. P. (2020). “Full body pose estimation of construction equipment using computer vision and deep learning techniques.” *Automation in Construction*, Elsevier, 110(November 2019), 103016.
- Luo, H., Xiong, C., Fang, W., Love, P. E. D., Zhang, B., and Ouyang, X. (2018). “Convolutional neural networks: Computer vision-based workforce activity assessment in construction.” *Automation in Construction*, Elsevier, 94(July), 282–289.
- Luo, X., Li, H., Wang, H., Wu, Z., Dai, F., and Cao, D. (2019). “Vision-based detection and visualization of dynamic workspaces.” *Automation in Construction*, Elsevier, 104(December 2018), 1–13.
- Martinez, P., Al-Hussein, M., and Ahmad, R. (2019). “A scientometric analysis and critical review of computer vision applications for construction.” *Automation in Construction*, 107(July).
- Park, M. W., and Brilakis, I. (2012). “Construction worker detection in video frames for initializing vision trackers.” *Automation in Construction*, Elsevier B.V., 28, 15–25.
- Rahimian, F. P., Seyedzadeh, S., Oliver, S., Rodriguez, S., and Dawood, N. (2020). “On-demand monitoring of construction projects through a game-like hybrid application of BIM and machine learning.” *Automation in Construction*, Elsevier, 110(November 2019), 103012.
- Rezazadeh Azar, E., Dickinson, S., and McCabe, B. (2013). “Server-customer interaction tracker: Computer vision-based system to estimate dirt-loading cycles.” *Journal of Construction Engineering and Management*, 139(7), 785–794.
- Seo, J., Han, S., Lee, S., and Kim, H. (2015). “Computer vision techniques for construction safety and health monitoring.” *Advanced Engineering Informatics*, Elsevier Ltd, 29(2), 239–251.
- Sherafat, B., Ahn, C. R., Akhavian, R., Behzadan, A. H., Golparvar-Fard, M., Kim, H., Lee, Y. C., Rashidi, A., and Azar, E. R. (2020). “Automated Methods for Activity Recognition of Construction Workers and Equipment: State-of-the-Art Review.” *Journal of Construction Engineering and Management*, 146(6).
- Soga, K., and Schooling, J. (2016). “Infrastructure sensing.” *Interface Focus*, 6(4).
- Soltani, M. M., Zhu, Z., and Hammad, A. (2016). “Automated annotation for visual recognition of construction resources using synthetic images.” *Automation in Construction*, Elsevier B.V., 62, 14–23.
- Sonka, M., Hlavac, V., and Boyle, R. (1993). *Image Processing, Analysis and Machine Vision. Image Processing, Analysis and Machine Vision*.
- Wang, Z., Li, H., and Zhang, X. (2019). “Construction waste recycling robot for nails and screws: Computer vision technology and neural network approach.” *Automation in Construction*, Elsevier, 97(March 2018), 220–228.
- Wei, R., Love, P. E. D., Fang, W., Luo, H., and Xu, S. (2019). “Recognizing people’s identity in construction sites with computer vision: A spatial and temporal attention pooling network.” *Advanced Engineering Informatics*, Elsevier, 42(February), 100981.
- Wu, J., Cai, N., Chen, W., Wang, H., and Wang, G. (2019). “Automatic detection of hardhats worn by construction personnel: A deep learning approach and benchmark dataset.” *Automation in Construction*, Elsevier, 106(February), 102894.
- Xia, Y., Jian, X., Yan, B., and Su, D. (2019). “Infrastructure safety oriented traffic load monitoring using multi-sensor and single camera for short and medium span bridges.” *Remote Sensing*, 11(22).
- Yan, X., Zhang, H., and Li, H. (2019). “Estimating Worker-Centric 3D Spatial Crowdedness for Construction Safety Management Using a Single 2D Camera.” *Journal of Computing in Civil Engineering*, 33(5), 1–13.
- Yan, X., Zhang, H., and Li, H. (2020). “Computer vision-based recognition of 3D relationship between construction entities for monitoring struck-by accidents.” *Computer-Aided Civil and Infrastructure Engineering*, 1–16.

- Yang, J., Park, M. W., Vela, P. A., and Golparvar-Fard, M. (2015). "Construction performance monitoring via still images, time-lapse photos, and video streams: Now, tomorrow, and the future." *Advanced Engineering Informatics*, Elsevier Ltd, 29(2), 211–224.
- Yang, J., Shi, Z., and Wu, Z. (2016). "Vision-based action recognition of construction workers using dense trajectories." *Advanced Engineering Informatics*, Elsevier Ltd, 30(3), 327–336.
- Yang, X., Li, H., Huang, T., Zhai, X., Wang, F., and Wang, C. (2018). "Computer-Aided Optimization of Surveillance Cameras Placement on Construction Sites." *Computer-Aided Civil and Infrastructure Engineering*, 33(12), 1110–1126.
- Yu, Y., Li, H., Umer, W., Dong, C., Yang, X., Skitmore, M., and Wong, A. Y. L. (2019a). "Automatic Biomechanical Workload Estimation for Construction Workers by Computer Vision and Smart Insoles." *Journal of Computing in Civil Engineering*, 33(3), 1–13.
- Yu, Y., Li, H., Yang, X., Kong, L., Luo, X., and Wong, A. Y. L. (2019b). "An automatic and non-invasive physical fatigue assessment method for construction workers." *Automation in Construction*, Elsevier, 103(February), 1–12.
- Zhang, H., Yan, X., Li, H., Jin, R., and Fu, H. F. (2019). "Real-Time Alarming, Monitoring, and Locating for Non-Hard-Hat Use in Construction." *Journal of Construction Engineering and Management*, 145(3), 1–13.
- Zhang, M., Shi, R., and Yang, Z. (2020). "A critical review of vision-based occupational health and safety monitoring of construction site workers." *Safety Science*, Elsevier, 126(July 2019), 104658.
- Zhong, B., Wu, H., Ding, L., Love, P. E. D., Li, H., Luo, H., and Jiao, L. (2019). "Mapping computer vision research in construction: Developments, knowledge gaps and implications for research." *Automation in Construction*, Elsevier, 107(July), 102919.

AR-BASED AND USER-CENTERED APPROACH TO THE ON-SITE DESIGN DECISION SUPPORT FOR BUILDING REMODEL PROJECTS

Sanghoon Lee & Jinsung Kim & Dahngyu Cho & Jin-Kook Lee

Dept. of Interior Architecture & Built Environment, Yonsei University, Seoul, Republic of Korea

ABSTRACT: *This paper shows an Augmented Reality (AR) based and user-centered design approach to the on-site design decision-support system using a private design object server. Because of various kinds of client needs, user-centered decision-support even in the early phase of design is one of keys to design satisfaction, specifically in building remodel projects. Design communications usually hard to fully deliver design ideas to the client at offsite, because the majority of conventional media is usually two-dimensional drawings and renderings. Hence AR could be utilized as one of the intuitive design communication media at on-site to provide one of realistic media, simply because it could display some overlay digital images on top of actual views. As one of the AR-based design decisions supporting approaches, this paper describes how user can change the conceptual design visualized at on-site using a private design object server, specifically to choose candidate design among lots of alternatives. The design object server has been constructed by collecting pre-build design objects using Unity 3d. At on-site, users can change the visualized design by using design objects imported from the server and perform more intuitive and interactive design communication. The demonstration in this paper has been examined at the actual project for enhancing a university library interior.*

KEYWORDS: *Augmented Reality, User-Centered Design, Design Communication, On-site Design Visualization.*

1. Introduction

Communication in the architectural design process is carried out to deliver information among the participants including designers, workers, clients, etc. Various communication media such as can be used in this process, but using visual media-based communication which CAD(Computer-Aided Design) based drawings such as elevations, cross-sectional, and floor plans or rendered images in off-site are conventional ways to efficiently conveying complex design information (Koutamanis et al. 1993). Visual communication, which enables intuitive information delivery, can be miscommunicated due to limitations of the each medium's characteristics (Kalay 2004). Also, the more complex the design plan, the more limited to deliver design information of the 3D space in 2D. Therefore, VR(Virtual Reality) and AR(Augmented Reality) are used as media for improving design communication through direct experience and information delivery of design proposals (Altabtabai et al. 2015).

VR and AR are being used in various fields such as tourism, education, and medical care because of their direct experience and the ability to deliver in-depth information through experiences in three-dimensional space. In this trend, the architectural field also has been applied to simulation and construction review in various areas such as design, construction, and maintenance (Alizadehsalehi et al. 2020). Also, AR-based visualization is studying for multiuser collaboration for enhancing communication in various fields through whole AEC/FM stages (Architecture, Engineering, Construction and Facility Management) (Cheng et al. 2020).

In the design phase, AR is being studied as a visualizing design information. Because it is possible to visualize and directly experience in the natural background. In particular, AR is more effective in interior remodeling for delivering design information. Because interior remodeling is targeting for an existing space. As a result, design alternatives directly experienced to users in on-site.

In this study, AR was used to visualize the conceptual design alternatives of interior remodeling at on-site targeting the real space inside the building. This paper proposes a way to improve the visual communication between the designer and the client by visualizing the design in the field using the AR feature that can visualize the virtual objects and information together with the information of the surrounding sites. Applying it to the case of improving the space of the university's library, this study conducted on-site AR visualization of the design. The process of this paper is summarized as follows:

1) Considering the importance of visualization in the design communication and AR-based studies in the architecture.

2) Establish a process for visualizing on-site AR design plans

3) Demonstration of on-site AR-based design visualization of 'Y' university library of the design alternatives to support design decision.

2. Background

2.1 Architectural Design Communication

Architectural design is carried out through communication-based collaboration among participants, and it is the process of deriving the optimal design through communication that exchanges opinions and information using appropriate media (Fig. 1). User-centered design is defined as a design process framework and aims to improve the quality and satisfaction of works for users (ISO 13407, 2010). Because of the diversification of client needs, user-centered design from the early phase of the design process is discussing as one of the methods for improving design satisfaction, specifically in a building remodel projects. For a user-centered design approach, smooth communication between participants is one of the important factors affecting design quality improvement. There is a lot of communication media available in the design process such as voice, text, and image, and choosing proper media is one of the key factors for better communication. Because the function of communication could be limited depending on the characteristics of the media (Kalay 2004). Among them, Visual media such as drawings, rendered images, and photos could be more efficient way rather than verbal or text-based architectural communication. Because visualization of architectural information for communication, because of the nature of humans, much of communication is visually related. Although the communication in the design process is tremendous and still being actively studied, this study limited to communication between designers and clients in the remodeling process.

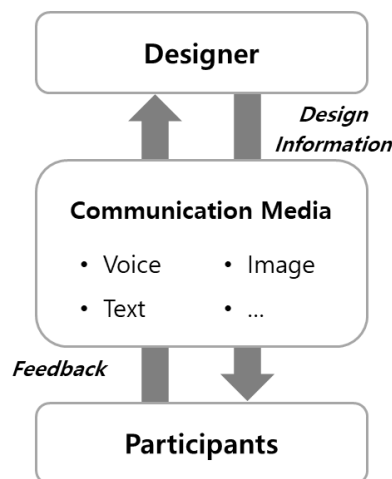


Fig. 1. An example of the design communication process (Kalay 2004)

2.2 Immersive media for Design Communication

During the conventional architectural process, visual media used for efficient communication include from simple sketches, elevations, sections, floor plans to 3D modeling, rendering images, and space models, which could be possible through the development of CAD. Among them, the drawings deliver design information intensively as a promised symbol, but not be an effective medium for communication with a client who lacks expertise in design. On the other hand, pictures or rendered images generated through 3D models express direct and intuitive information about the design which doesn't need special expertise for understanding. Hence it is one of the most commonly used design communication media. However, image-based representations also have limitations for delivering enough information to the client. Because it is hard to project three-dimensional spatial information into two-dimensional media such as paper, monitor, and so on.

Therefore, VR and AR-based visualization studies are conducted as an alternative way to improve communication between designers and clients. Because they are relatively free from time and cost constraints and provide direct experience to the users. Hong (2013) studied in the design studio class that the direct experience through the online virtual environment on the outputs helps to improve design communication as well as understanding various design information, not only design but also design intention, etc.

AR is a technology that seamlessly augments virtual objects and information on the user's environment and is characterized by being able to grasp the context of the surrounding environment. Azuma (1997) described the three characteristics of AR: 1) loading virtual objects into real environments, 2) real-time interaction, and 3) placing them in 3D spaces. Visualization through AR could provide a more realistic experience to users than VR. Because it combines virtual objects and information on the real spaces (Baus et al. 2014). Based on these characteristics, researches are being conducted to efficiently use AR in the architectural field (Golparvar-Fard et al. 2009, Altabtabai et al. 2015).

2.3. Objective

In the interior architecture and built environment field, AR is used as a visualization tool in the various stages. However, AR-based visualization researches are mainly focused on visualizing an object of a small scale by loading design objects using a marker or using an external camera to augment the monitor from a distance, rather than being visualized on a real scale on-site. This study proposes on-site AR-based design visualization to support design decision that can consider the surrounding environment of the real space in the remodeling and can improve the communication of the design process (Fig. 2). The objectives of this paper are summarized as follows:

- 1) AR-based on-site design decision support approach for client-designer communication through visualization of design alternatives.
- 2) Demonstration of on-site AR-based design decision approach to 'Y' university library

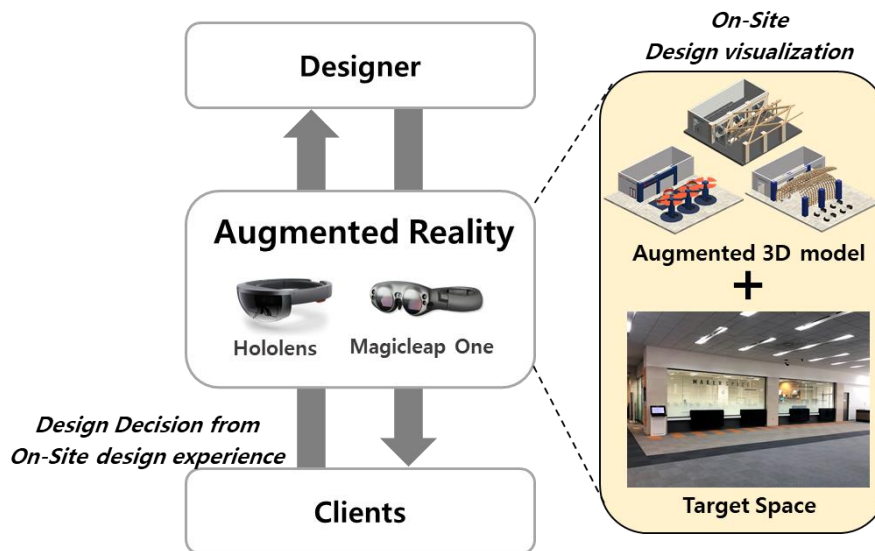


Fig. 2. An example of AR-based design communication

3. AR-based On-site Design Decision Support Process

3.1 AR-based Design Alternatives Visualization Process for Design Decision Support

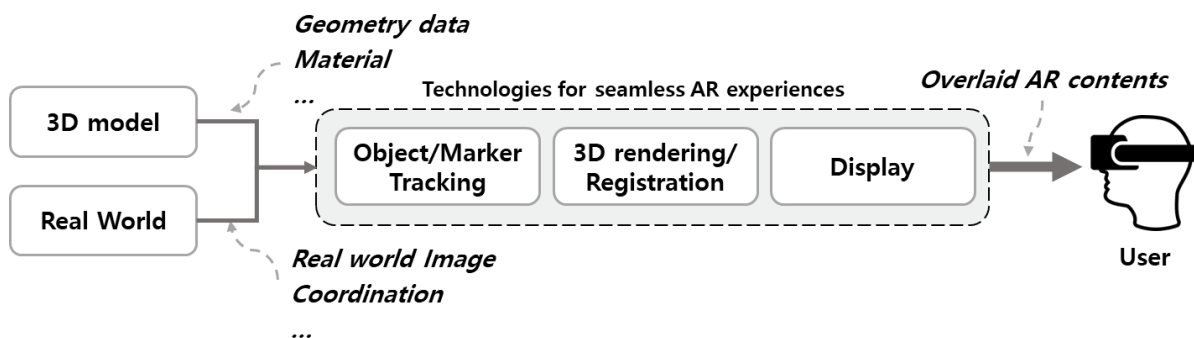


Fig. 3. Example of AR visualization process for seamless AR experience

Many technologies are used in AR. But, object/marker tracking, 3D rendering/registration, displays are technologies for seamless AR experience. With those technologies, examples of AR implementation processes are as shown in (Fig. 3). 1) Using a camera of AR device, 3D virtual object is loaded and visualized to the user based on image, feature point, and coordinate information obtained from the surrounding space. 2) At this time, in order to designate the coordinate where the virtual object is to be loaded, the virtual object is registered with the location of the surrounding environment by tracking the movement of the device or the surrounding environment and techniques such as marker recognition. 3) 3D rendering technology of the surrounding space and virtual objects are utilized to enable the user to experience seamlessly.

The general AR-based design visualization process is followed (Bille et al. 2014). 1) Acquire and generate 3D design model through 3D modeling tool, laser scan, photogrammetry, etc. 2) Create AR contents by programming in game engines such as adjust material, adding interaction, interface design for maximizing visual communication. 3) On-site AR design visualization is conducted using programmed AR contents. This study focuses only on programming for AR-based visualization and visualization in on-site AR environments. Because 3D model authoring can be done in various ways and beyond the scope of the study (Fig. 4).

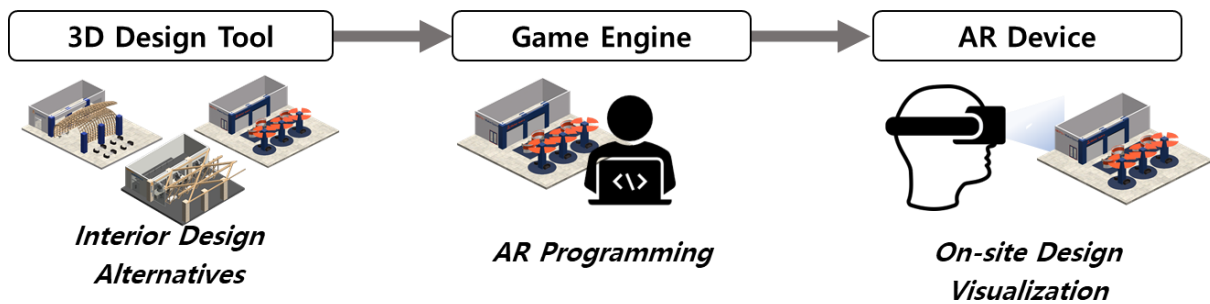


Fig. 4: On-site Design Visualization Process Overview

3.2 AR Programming for Design Decision Support

3D design models can be loaded into game engines with various formats such as Fbx, Obj, etc. AR contents could be programmed in game engine such as adding interaction with virtual objects, object tracking, or marker recognition. The commonly used two game engines for creating AR are Unity 3D and Unreal Engine 4. This study used Unity 3D for creating AR contents.

Unity's objects are called GameObject which can be added various properties and interactions. Various functions can be implemented by adding scripts written based on C# as well as functions such as physics properties and light sources basically provided by Unity. Software development kit (SDK) and an API (Application Programming Interface) are utilized to easily use object/motion tracking and registration for visualization on an AR device. The AR design produced through a programming process such as interaction and interface addition are visualized in a display environment selected according to a user's purpose. For the visualization of the on-site design proposed in this study, it is appropriate to use a portable device such as HMD (Head-Mounted Display) or handheld display. This study used HMD display for providing users an immersive experience.

3.3 Design object server for On-site Design Decision Support

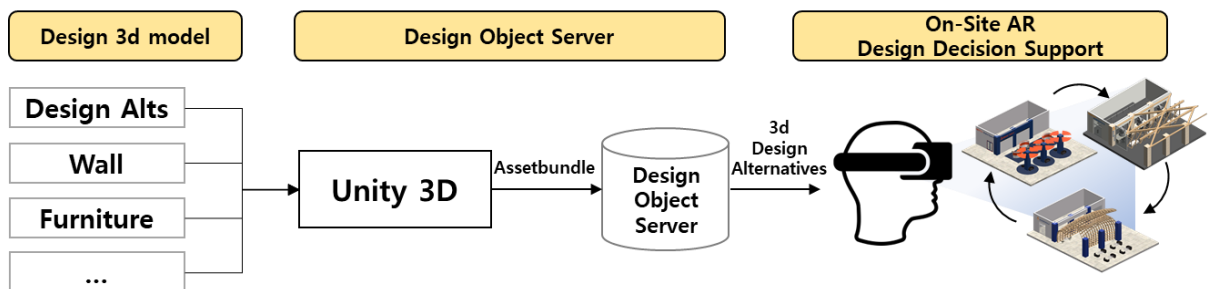


Fig. 5: AR-based On-site Design Decision process using Design Object Server

Nowadays several plugins for integrating 3d models to AR/VR visualization such as Unity reflect which

supports real-time visualization in Revit. But still commonly used method for AR visualization is using game engines, because of the modeling platform, or device dependent functions such as LIDAR in iPad. Therefore, conventional design decision process had the inconvenience of rebuilding from the game engine to the AR device when the design change happens. For enhancing the AR-based on-site design decision support system, this study constructed a private design object server with 3d models of design alternatives and objects. This study used Assetbundle function in Unity 3D for constructing private design object server. Assetbundle is a file that contains pre-built assets such as models, textures to stream via the web request and instantiates at runtime. Assetbundle is commonly used for update after release such as DLC (Downloadable contents), reduction initial file size for installation, etc. In this context, this study used Assetbundle for constructing design object server and using constructed data at on-site AR-based design decision support (Fig. 5). This study collected three design alternatives and furniture objects such as chair, desk for demonstration.

4. Demonstration of On-site AR Interior Design Visualization

4.1 Visualization Scenario overview

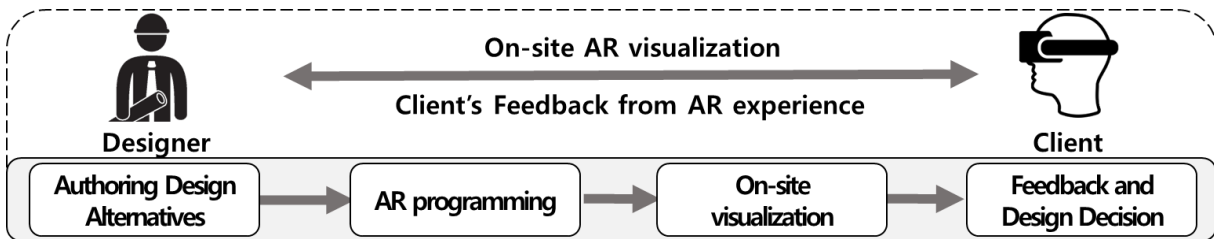


Fig. 6: On-site AR design Visualization Scenario

Based on the AR visualization process discussed above, the demonstration of AR-based design visualization is conducted. Target space for AR is the lobby space on the 1st floor of the Y university library in Seoul, Korea. To improving and utilizing the target space, three design alternatives were generated. Design A is a design consisted of a design of a resting space with a preform ceiling structure shaped like a bookshelf. Design B is a design for telepresence-based study zone that utilizes open space and consists of a space for real-time lectures between remote two campuses. Design C is a design for an extended makerspace adjacent to the target space and is equipped with equipment such as a robot arm (Fig. 6).

Following the Autodesk Revit was used for authoring design alternatives. 3D data was imported in the game engine in fbx format. Polygon optimization is an optional process for ensuring frame rate due to limitation of performance. This study used Unity 3D as a game engine for AR programming, adding interaction elements with the design, designing the user interface. For AR visualization, tablet PC has been used. Information recognition and design visualization were performed. Interactions for each design are based on the device controllers, and interactions are implemented through the addition of Unity's C # script.

4.2 AR Programming for Design Decision Support

The on-site visualization of the design can be intuitively understood because the client can directly experience the design and get various contextual information from the surrounding space, rather than the design visualized through 3D modeling and rendering. In addition, based on the information of the surrounding environment, the user can change the design and can be used more effectively when adding additional functions for effective visualization. Therefore, in this study, not only the simple visualization of the design completed through the computer but also the user can change the design elements of the visualized design based on the actual surrounding environment for better design decision through the interface in the AR device. Users can interact with the design alternatives in various way, such as gesture, voice, and controller. The functions implemented for effective on-site AR design visualization in this study are shown in Table 1.

In addition, an interface that can move in response to the user's head pose and eye movement. We have set it could be changed visible/invisible so that it does not interfere with the visual experience. The user can use the on-site visualization functions and check the object information more conveniently through the interface.

Table 1. Functions for effective on-site AR Design Decision Support

Function	Description
Spatial mapping	Scan surrounding spaces to obtain coordinates for placement objects in more accurate location.
Load design Alternatives	Load designs alternatives on real and 1/200 scales to compare multiple designs in one place
Object manipulation	User can change furniture used in the design by moving, adding, or deleting objects
Material/color change	User can change the materials, shape, etc. used in the design on-site. So that user could select material/color that is most suitable for the surrounding environment

4.3 AR-based On-Site Design Decision Result

The results of the visualization of the site-based AR design are summarized in Table 2. Visualization results in the table are vary depending on background conditions such as the device's field of view and lighting. The target space is adjacent to the maker space and is currently used only as a passageway. As a result of the on-site visualization of the design using the implemented application, it was possible to understand the target space for each design and visualize the design. In addition, in the field, the user can change the design through various functions such as material and furniture change for the design and visualize the changed design and check the mood of the indoor space. Users can compare and visualize the initial design at on-site in real-time.

Table 2. On-site AR Visualization and Design Decision results

Target Space Overview			
Design Overview	Design Alt A	Design Alt B	Design Alt C
Visualization in Conventional 3D tools	<p>Resting space</p>	<p>Telepresence study zone</p>	<p>Extended maker space</p>
On-site AR Visualization	<p>Design A Load Done</p>	<p>Design B Load Done</p>	<p>Design C Load Done</p>
Design Decision by User	<p>Material Change Done!</p>	<p>Color Change Done!</p>	<p>Furniture Change Done!</p>

5. Conclusion/Summary

This study proposed a user-centered approach for design decision support system using AR-based on-site design visualization as a communication media between designers and clients. Unlike the existing 2D-based approaches such as monitors and paper, the proposed method enables a diversified review and intuitive understanding of the design by providing a direct experience with the early concept of design. In addition, unlike the virtual reality approach, AR enables on-site visualization, enabling a deep and contextual understanding of the design and the surrounding environment. It could be an efficient way of understanding and interacting with design.

Until now, the computing power of HMD or handheld display used for on-site AR is insufficient compared to Non-HMD, such as desktop, so the visualization through complicated processing of data is still insufficient. Moreover, the field of view of HMD, which is directly linked to the user's visual experience, is too narrow and still difficult to provide a seamless experience. Nevertheless, the hardware performance of AR devices is rapidly developing and for compensate the computing power, using cloud computing or network also being studied.

This study was developed and described as a concept example of AR utilization method to connect a remote campus based on a high-speed network as part of the education advancement project through diversification of contents of the university and IT technology connection. Through the connection of AR and high-speed networks, it enables us to propose an environment that can share designs visualized in the field from a distance and collaborate in real-time.

Although this study only focuses on the visualization of AR-based design, in the future, it is possible to create a user-centered design in the initial design stage, or to develop and modify and optimize a machine learning-based design. AR is expected to be used not only as a visualization media but also as a media for communication and collaboration.

Acknowledgement

This work was supported by the National Research Foundation of Korea (NRF) grant funded by the Korea government(MSIT) (NRF-2019R1A2C1007920)

REFERENCE

- Y.E. Kalay (2004). Architecture's New Media: Principles, Theories, and Methods of Computer-Aided Design, *The MIT Press, Boston, MA, USA*
- Heydarian, A., Pantazis, E., Wang, A., Gerber, D., & Becerik-Gerber, B. (2017). Towards user centered building design: Identifying end-user lighting preferences via immersive virtual environments, *Automation in Construction*, 81, 56–66.
- Zhang, Y., Liu, H., Zhao, M., & Al-Hussein, M. (2019). User-centered interior finishing material selection: An immersive virtual reality-based interactive approach, *Automation in Construction*, 106. <https://doi.org/10.1016/j.autcon.2019.102884>
- Barcellini, F., Prost, L., & Cerf, M. (2015). Designers' and users' roles in participatory design: What is actually co-designed by participants, *Applied Ergonomics*, 50, 31–40.
- Koutamanis, Alexander and Mitossi. (1993). Vicky, Computer vision in architectural design, *Design Studies*, Vol 14 No. 1, 40-57
- O. Baus, S. Bouchard. (2014). Moving from virtual reality exposure-based therapy to augmented reality exposure-based therapy: a review, *Front. Hum. Neurosci.* 8, 112,
- Ronald T. Azuma (1997). A Survey of Augmented Reality in Presence: Teleoperators and Virtual Environments 6, 4, 355-385.
- Hong, S.W (2014). The Applications of Online, Multi-User Virtual Environments for Architectural & Interior Design Communication, *Journal of the Korean Housing Association*, Vol.

Marques, B., Santos, B. S., Araújo, T., Martins, N. C., Alves, J., & Dias, P. (2019). Situated Visualization in the Decision Process through Augmented Reality. *Proceedings of the International Conference on Information Visualisation*, 2019(Iv), 13–18. <https://doi.org/10.1109/IV.2019.00012>

Juan, Y. K., Chi, H. Y., & Chen, H. H. (2019). Virtual reality-based decision support model for interior design and decoration of an office building. *Engineering, Construction and Architectural Management*.

Duque, E., Fonseca, G., Vieira, H., Gontijo, G., & Ishitani, L. (2019). A systematic literature review on user centered design and participatory design with older people. *IHC 2019 - Proceedings of the 18th Brazilian Symposium on Human Factors in Computing Systems*.

R. Bille, S.P. Smith, K. Maund, G. Brewer, (2014). Extending building information models into game engines, *Proceedings of the 2014 Conference on Interactive Entertainment*, ACM, 2014, 1-8,

Cheng, J. C. P., Chen, K., & Chen, W. (2020). State-of-the-Art Review on Mixed Reality Applications in the AECO Industry. In *Journal of Construction Engineering and Management* (Vol. 146, Issue 2). American Society of Civil Engineers (ASCE).

Alizadehsalehi, S., Hadavi, A., & Huang, J. C. (2020). From BIM to extended reality in AEC industry. *Automation in Construction*, 116(March), 103254.

IMPROVING CONSTRUCTION RISK ASSESSMENT VIA INTEGRATING BUILDING INFORMATION MODELING (BIM) WITH VIRTUAL REALITY (VR)

Rolim A. L.

SAC National Civil Aviation Secretary, DF, Brazil

Valente G. A.

GVBIM, MG, Brazil

Keskin B,

Syracuse University, NY, USA

ABSTRACT: *Developing a risk assessment strategy is a continuing process throughout life cycles construction projects. As today's urban environment and infrastructure needs require Architecture, Engineering, and Operations (AECO) industry to deliver complex and large-scale projects at a faster pace, traditional risk management approaches become ineffective in adapting proactive approaches. This study aims to provide a novel BIM-enabled risk assessment approach via leveraging synergies between BIM processes and virtual reality. A qualitative research methodology, which includes an explanatory case study on an airport airside construction project followed by semi-structured interviews, is adopted. Extensive review for historical data conducted and a set of high-impact risks is identified. Accordingly, several what-if scenarios are simulated in a VR-integrated BIM environment. Based on the findings of the study, enabling immersive experiences for project stakeholders through combining virtual reality with BIM can lead to better risk identification therefore more accurate and realistic risk mitigation plan to support airport operators and risk management teams.*

KEYWORDS: *Risk Management, 4D BIM, Virtual Reality, Construction innovation.*

1. INTRODUCTION

The aviation industry has major impacts on development of cities. Infrastructure and transportation services are basic ingredients for a country's economic growth, development and production (Kapur, 1995). Construction projects within an operational airport environment have unique challenges due to complexities associated with managing investment and logistics. According to Binnekade (2006), airports face multiple challenges, including meeting capacity demands, providing enhanced public service and increasing revenue. These challenges can indicate current business and operational processes need revitalization. Airports have the potential to become a multi-modal transportation hub including substantial areas that can be expanded in order to meet the needs of the community; and growth and changes in the industry. Thus, construction projects should be managed effectively while operating airports seamlessly.

There are many uncertainties related to airport construction projects. The literature suggests that they face risks and consequences during the development and delivery of a project at a higher rate compared to building projects. For example, a Flyvbjerg (2003) found that 20% of 167 transportation infrastructure projects delivered throughout previous 70 years were initially underestimated while the rest was overestimated

In recent years, Building Information Modelling (BIM), as one of the main interest areas in the AECO industry, is also expected to play a significant role in facilitating risk management throughout design, construction, and maintenance phases of a project. BIM is defined as a modelling technology and associated set of processes that produce, communicate, and analyze building models through a three-dimensional representation of non-redundant data (Eastman et al, 2011). Implementation of risk management in the industry is still a knowledge and experience based manual undertaking (Forsythe, 2014). As projects are completed by a team cooperatively, any common risks will be identified and treated individually; and the corresponding information will be documented and sometimes this work will be ignored or forgotten (Kazi, 2005).

Accordingly, this research aims to provide a novel approach that combines virtual reality with BIM which can lead to more efficient risk assessment, therefore a more accurate and realistic risk mitigation plan to support airport operators and risk management teams. The proposed risk assessment approach was implemented at a Brazilian airport construction project, during the planning phase. Semi-structured interviews were conducted using a VR-integrated BIM environment with airport stakeholders in order to evaluate risks that could have adverse impact to the project and register this information. The associated use of an airport BIM model data with

risk management, enables risk information to be recorded and communicated to a wide range of project stakeholders, which is also a benefit of this approach.

2. RISK ASSESSMENT

2.1 Risk Assessment in Airport Projects

The Airport Cooperative Research Program – ACRP (ACRP, 2014), states that project risk is an uncertain future event or condition that, if it occurs, has a negative effect on achieving the project objectives of cost, schedule, scope, or quality. It basically consists of three elements: A future event, which, if eliminated or corrected, would prevent a potential consequence from occurring, a probability (or likelihood) assessed at the present time of that future event occurring and impact (or effect) of that future event. The Association for Project Management defines risk as the combination of the probability or frequency of the occurrence of a threat or opportunity (APM, 2006).

Risk management is a system aiming to recognize, quantify, and manage all risks exposed in the business or project (Flanagan and Norman, 1993). The International Organization for Standardization (ISO, 2009) defines the process of risk management involving application of a systematic and logical method for establishing the context, creating a communication and consultation mechanism; and constructing risk management identification, analysis, evaluation, treatment, monitoring, and recording in a project.

The purpose of risk assessment is to provide evidence-based information and analysis to make informed decisions on how to treat risks and how to select between options. Risk assessment comprises the core elements of the risk management process which are defined in ISO 31000 (ISO, 2009) and described as the following:

- communication and consultation;
- establishing the context;
- risk assessment (comprising risk identification, risk analysis and risk evaluation);
- risk treatment;
- monitoring and review.

The implementation of traditional risk management is still a manual undertaking, the assessment is heavily reliant on experience and mathematical analysis, and the decision making is frequently based on knowledge and experience-based intuition, which always leads to a decreased efficiency in the real environment (Shim et al., 2012). Based on ACRP Report 131 (2015), the most common risk identification used by airports are brainstorming, checklists, inspection reports, structured what-if and safety audits.

According to Practice Standard Project Risk Management (PMI, 2009), there is a paradox about project risk that affects most projects. In early stages of a project, the level of risk exposure is at its maximum but information on the project risks is at a minimum. This situation does not mean that a project should not go forward because little is known at that time. Rather, there may be different ways of approaching the project that have different risk implications. The more this situation is recognized, the more realistic the project plans and expectations of results will be.

Also, a literature review was conducted to seek the most used practices and tools used by airports. Only Airport Cooperative Research Program Report 116, Guidebook for Successfully Assessing and Managing Risks for Airport Capital and Maintenance Projects (ACRP, 2014) presented an extensive research to provide a step-by-step process for evaluating and managing risks inherent in airport projects. This report highlighted general risks categories and classified it into five different groups: Technical, operational, external, organizational and commercial (see Table 1). Risks can be categorized by sources of risk and grouping risks into categories can lead to the development of more effective responses by focusing attention and effort on the areas of highest exposure (PMI, 2017).

Table 1: Risks in Airport Projects (ACRP, 2014).

Technical	Operation	External	Organizational	Commercial
Scope definition	Safety	Client	Resources	Contractual Terms and Conditions
Requirements	Security	Political	Dependencies	Suppliers and vendors
Quality	Interfaces	Public Relations	Financial Capacity	Procurement Process

Complexity	Site condition	Market Conditions	Contractors
Site Conditions		Weather	
		Environmental	
		Property acquisitions	
		Regulatory changes	
		Permitting	

3. METHODOLOGY

3.1 Proposed Framework

The developed framework (given in Fig.1) prescribes a risk assessment strategy and process that allows immersive experience for research participants via integrating Building Information Modeling (BIM) with Virtual Reality (VR) in order to promote a better identification and recognition of project risk situations, and subsequently development of risk mitigation plans. It consists of four main parts: 1) Establishing a context, 2) Developing Scenarios, 3) Virtual Reality session for risk identification and 4) Data register and Analysis. The framework proposes to consolidate risk scenarios with detailed information using a BIM model and virtual reality to provide participants a more realistic experience.

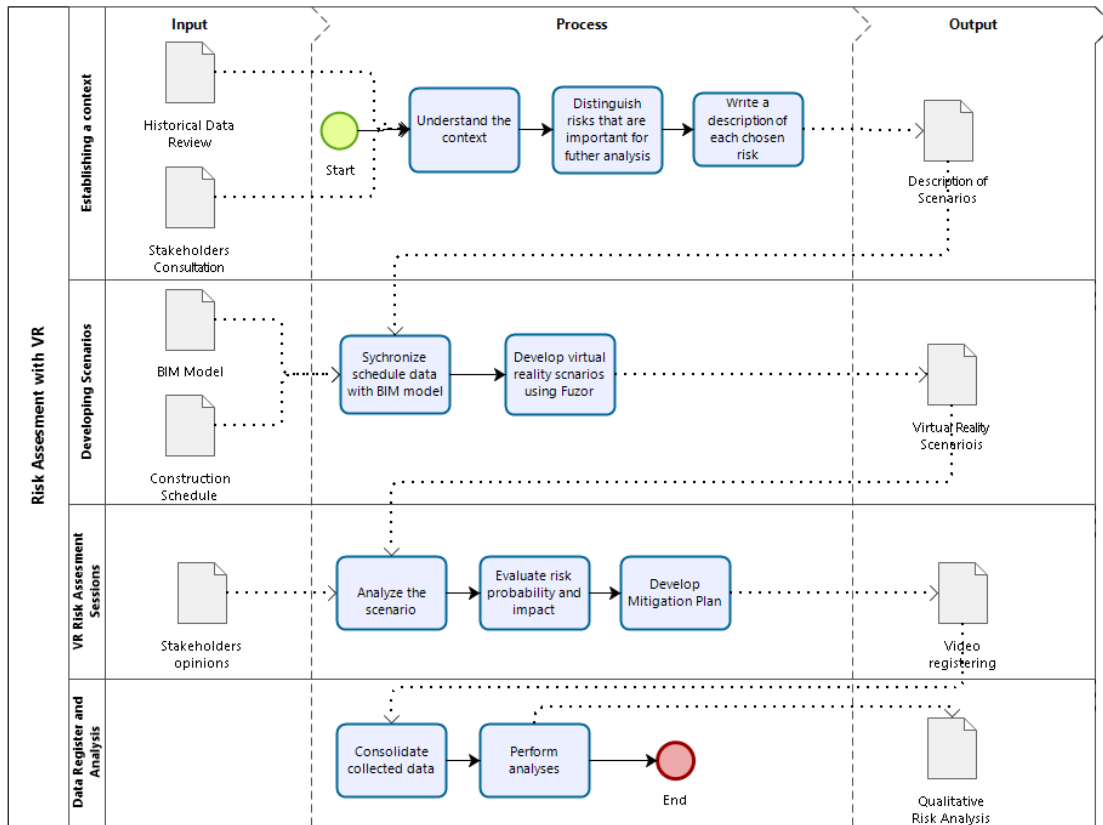


Fig. 1: Proposed Framework

The first part of this framework consists of understanding the complexity of the project based on historical data review and consulting with stakeholders. In this step, the main objective is to obtain a description of scenarios that will be simulated during risk assessment.

The second step consists of BIM model development synchronized with the project's construction schedule and development of virtual reality risk scenarios. Finally, after modelling the scenarios, stakeholders participated in semi-structured interviews which were conducted while participants were VR headsets, to analyze and evaluate risks. They also evaluated the use of VR technique in comparison with traditional methodologies. Furthermore, the collected data were consolidated qualitative risk and thematic analysis of survey responses.

3.2 Case Study - Governador Valadares Airport - Runway Reconstruction

In this research, the Coronel Altino Machado de Oliveira Airport (IATA: GVR, ICAO: SBGV), located in the city of Governador Valadares, state of Minas Gerais, was used as a case study. It is a Brazilian regional airport, having approximately an annual number of passengers of 23,149. It has one runway (See Fig. 2) designated 07/25, according to its magnetic azimuth orientation, which is 1,700 m long and has a width of 30 m constructed with asphalt. The main scope of this airside construction project consists of a runway rehabilitation, marking signs, visual aids, taxiway, service lane, apron area, and a drainage system.



Fig. 2: Governador Valadares Airport runway

3.3 Development of Risk Scenarios

3.3.1 Historical Data Review

The objective of consulting the historical data was to identify events that were registered from experienced incidents during airport runway constructions with similar conditions and, based on this information, establishing the context considering internal and external parameters relevant for creating realistic risk scenarios. Hence, due to the lack of literature regarding risks in the construction of airport projects, there was a need to review the risk data basis registered by one of the authors, taking into consideration previous projects undertaken by Infraero, which is a Brazilian government corporation responsible for operating the main Brazilian commercial airports. This data basis registered airport runway projects over the past 05 years, with similar scope, that were analyzed and consolidated interviews with some airport experts (Rolim, 2015).

From analyzing reports of previous airside constructions, expert interviews, author's own experience, and analyzing the scope of Governador Valadares project, it was possible to understand the context and basic parameters for managing risks, considering relevant factors of the airport in order to better characterize and develop virtual reality scenarios.

3.3.2 Virtual Reality Risk Scenario

Relying on the studies of literature and historical review, a careful selection of five different comparable scenarios, genuinely similar to the current project was performed and simulated in a VR-integrated BIM environment, enabling immersive experiences for project stakeholders through combining virtual reality with BIM encouraging them to use their imagination to find risks which might affect the project and leading to better risk identification, and a more accurate and realistic risk mitigation plan to support airport operators and risk management teams.

An airside digital model (BIM) of Governador Valadares was developed using Revit®, considering the planning phase (4D) using the construction schedule that was created using MS Project® software. Also, project milestones were defined to coordinate the risk scenario occurrence. The model development also considered construction machinery and equipment performance histograms.

Fuzor® application was used for the virtual reality simulation because it provides a bi-directional data synchronization with Revit and a walk physical navigation feature which allows participants to virtually walk in the VR scene, encouraging project stakeholders to assess risks through the BIM model, visualizing the context, interacting with the scenario and being able to give an opinion not only based on imagination. During interviews, each volunteer used an Oculus RIFT® which is a virtual reality headset for scenarios visualization manufactured by Oculus VR. Therefore, participants were able to have a large field view of airside construction.

The main Virtual Reality Risk Scenario workflow is illustrated in Figure 4.

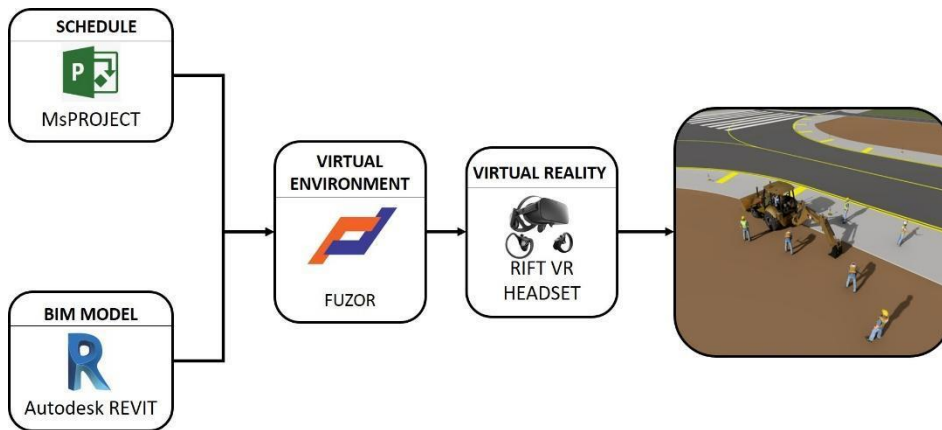


Fig. 4: Virtual Reality workflow

The what-if scenarios were simulated using this VR-integrated BIM environment and a sample of five virtual reality scenarios with high-impact risk were developed as described at Table 2.

Table 2 - What-if Scenarios

Scenarios	Description
01	Airport runway lighting system failure after a construction excavation performed by machinery
02	Excessive rain due to non-eventual weather conditions
03	A construction vehicle collision with PAPI (Precision Approach Path Indicator)
04	Failure of a paver during construction and near the reopening of airport operations
05	Aircraft departure delay precede the scheduled time to start construction services on the runway

3.4 Semi-structured Interviews Sessions

This section describes the survey process used in this research. A qualitative methodology was adopted, in which an explanatory case study on an airport airside construction followed by semi-structured interviews for data collection. The survey was carried out with airport staff who will be involved with the runway construction project. This research conducted seven interview sessions using virtual reality with the airport project collaborators, (shown in Fig. 3), via ensuring their understanding about the risk identification process and about the scenario they were visualizing. Each participant of this sample represents a different airport area, which resulted in a rich variety of expertise and skills.



Fig. 3: Governador Valadares Airport interviewees during VR session

Table 3 presents the profile of interview participants.

Table 3: Profile of airport staff.

Identification	Airport Role	Experience (years)	Organization
Interviewee 1	Airport Manager	11	Governador Valadares Airport Administration
Interviewee 2	Fire Service	15	Firefighters Corps
Interviewee 3	Aviation Security	3	Governador Valadares Airport Administration
Interviewee 4	Aviation Safety Inspector	4	Governador Valadares Airport Administration
Interviewee 5	Wildlife Hazard Manager	1	Governador Valadares Airport Administration
Interviewee 6	Air Navigation Supervisor	30	Socicam
Interviewee 7	Aviation Security	5	Governador Valadares Airport Administration

Initially, a 4D simulation model was presented to give participants a complete idea of the project's scope and schedule. After this introductory visualization, the sample of five different scenarios were presented and a facilitator asked some questions presented at Table 4 and interviewees were given the opportunity to identify any relevant risk, think about its possible causes, its consequences, and evaluate levels of probability and impact of each scenario. They were also allowed to identify more risks when possible. After this risk evaluation, all participants proposed mitigation plans. Finally, after experiencing this risk assessment approach with VR technique, they were asked to compare traditional methodologies, usually performed through brainstorming sessions, with VR- integrated BIM sessions proposed in this research.

Table 4: Interview Questions

Order	Survey question
1	What is your role at the airport?
2	What is the possible cause of this event?
3	What adverse impacts to the project would arise if this event occurs?
4	How do you evaluate the likelihood of this risk occurrence?
5	Could you describe with details major risks involved with the project or similar situations from your experience?
6	In comparison with traditional methodology, how do you evaluate the use of virtual reality in risk assessment?
7	What grade would you give to this risk assessment experience? (0-10)

The results from these VR sessions were recorded in order to capture all relevant information available. Then, the data was analyzed and registered.

4. RESULTS

The semi-structured interviews were carried out with airport stakeholders, according to the proposed research framework, using a VR-integrated BIM environment. Participants provided an evaluation about the level of probability of each scenario against severity using parameters presented at Table 5. Then, the levels of risk were determined using a scale from low to high by multiplying these two factors.

Table 5: Levels of impact and probability

Grade	Probability	Severity
1	Very Unlikely	Negligible
2	Unlikely	Minor
3	Possible	Moderate
4	Likely	Significant

Additionally, a risk matrix for risk scenarios analyzed in this research was developed, Fig. 4.

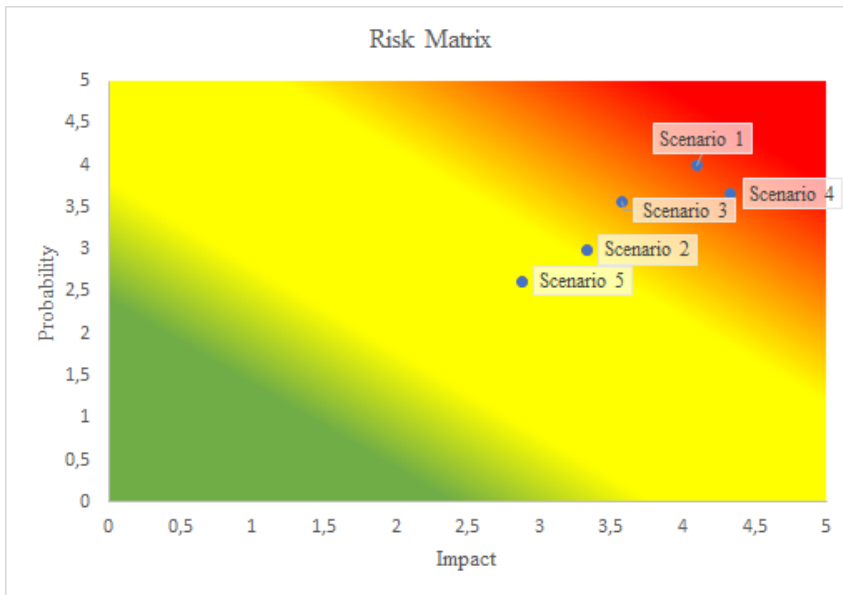


Fig. 4: Risk Matrix

Based on analysis performed, the risks scenarios with the highest score on this scale were associated with operational, technical and weather categories. However, their occurrence is caused mainly due to the lack of project information during the planning phase. It was possible to observe that, depending on their role at the airport, the information provided about the scenario had different insights regarding their expertise and level of experience.

Final survey questions refer to how participants evaluated the use of Virtual Reality technique on risk management process, through an inductive thematic analysis approach, the collected survey data about participants' opinion regarding VR sessions were analyzed and themes were defined in order to interpret results, (see Fig.5).

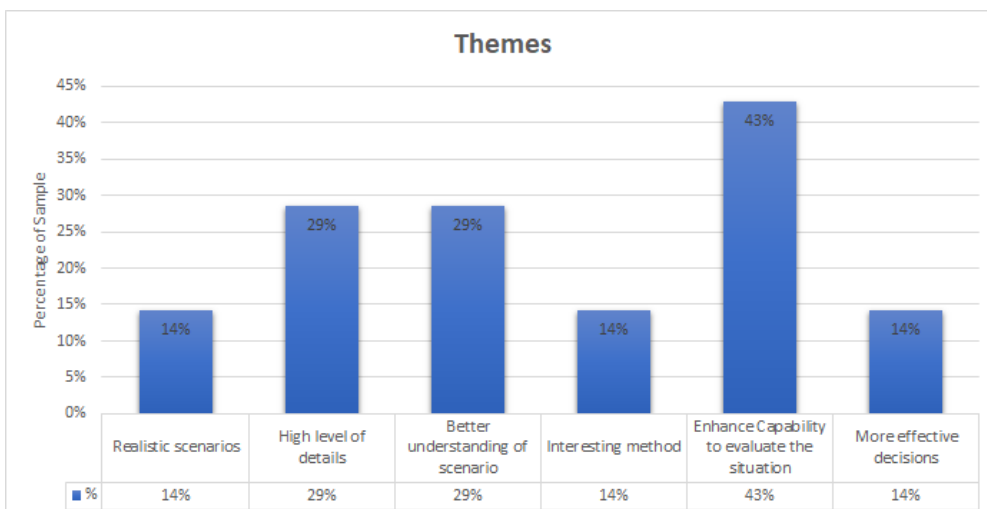


Fig. 5: Thematic analyses based on opinions of interviewees

It is seen that the code “Enhance Capability to Evaluate the Situation” has the higher percentage to stakeholders. During interviewees they observed that the use of VR during risk assessment by promoting an immersion in a simulated environment of the airside construction can provide a high level of details, allowing them to evaluate the situation, by means of impact and probability, not only by guessing or imagining the risk, but visualizing it.

Finally, interviewees evaluated the adoption of this risk assessment approach in comparison to traditional risk assessment with scores in a scale from 0 to 10. All participants attributed the highest score, 10.

5. CONCLUSION

This paper analyzed the current challenges of traditional risk management and examined the application of Virtual Reality technique to improve the process of risk assessment and proposed a framework considering this implementation. Findings revealed that by promoting an immersive experience it is possible to leverage participant's ability to identify and evaluate risks. Therefore, this approach can enhance the efficiency and accuracy of risk management, principally during the mitigation plan elaboration because it allows participants to recognize the project scenario with high level of details, considering all interfaces involved, also combined with project's schedule. The proposed method reduces uncertainties of context and scope about the project over participants, allowing them to have a better understanding on how to measure likelihood of risk occurrences, causality and its impacts, not only based on their imagination.

Based on the research findings, it was possible to demonstrate that the implementation of new technologies combined with BIM models can improve project management practices and help effectively to acquire better inputs during the project's planning phase.

For future work, the research team will establish a link between the data acquired and BIM model in order to perform the risk monitoring process during the construction to carry out further risk analysis.

6. ACKNOWLEDGMENT

The authors would like to acknowledge the support provided by airport manager Thiago Carvalho Lopes. The authors also would like to thank the interviewees for their time and contribution.

7. REFERENCES

- Airport Cooperative Research Program. (2014). Report 116: Guidebook for Successfully Assessing and Managing Risks for Airport Capital and Maintenance Projects. Transportation Research Board, Washington, D.C.
- Airport Cooperative Research Program. (2015). Report 131: A Guidebook for Safety Risk Management for Airports. Transportation Research Board, Washington, D.C.
- APM (2006) APM Body of Knowledge. 5th Edition, Association for Project Management, Princes Risborough.
- Baghdadi A. and Kishk M. (2015). Saudi Arabian aviation construction projects: Identification of risks and their consequences / *Procedia Engineering* Vol. 123, 32 – 40
- Binnekade F., Biciocchi R., O'Rourke B. E., and Vincent C., (2009) Creating Smarter Airports: An Opportunity to Transform Travel and Trade. IBM.USA
- Eastman, C., Teicholz, P., Sacks, R. & Liston, K. (2011). BIM handbook: A guide to building information modeling for owners, managers, designers, engineers and contractors, John Wiley & Sons.
- Flanagan, R., Norman, G., 1993. Risk Management and Construction. *Blackwell Scientific*, Oxford.
- Flyvbjerg, B., Skamris Holm, M.K., Buhl, S.L. (2003). How Common and How Large are Cost Overruns in Transport Infrastructure Projects? *Transport Reviews*, Vol. 23, n. 1, p. 71-88
- Forsythe, P., (2014). Proactive construction safety systems and the human factor. *Proc. Inst. Civ. Eng.: Manage., Procurement Law* Vol. 167, 242–252.
- ISO (2009). Risk Management – Risk Assessment Techniques, IEC/FDIS 31010:2009, *International Organization for Standardization*
- Kapur. A. (1995). Airport Infrastructure: The Emerging Role of the Private Sector. Washington D.C, The World Bank.
- Kazi, A. S. (2005). Knowledge management in the construction industry: A socio-technical perspective. *Information Technology Newsletter*, 16(1), 16-17.
- Project Management Institute (2017). A guide to the Project Management Body of Knowledge. *Project Management Institute*, 6th edition.

Rolim A. L. (2015). Application of Schedule and Risk Management Techniques in Airport Projects. *Fundação Getúlio Vargas - FGV, Brazil.*

PMI (2009). Practice Standard for Project Risk Management. *Project Management Institute.*

Shim, C.-S., Lee, K.-M., Kang, L.S., Hwang, J., Kim, Y., (2012). Three-dimensional information model-based bridge engineering in Korea, *Struct. Eng. Int.* 22, 8–13.

COLLABORATIVE SCHEDULING WITH 4D EXTENDED TO VIRTUAL REALITY

Mikael Viklund Tallgren, Mattias Roupé, Mikael Johansson

Department of Architecture and Civil Engineering, Chalmers University of Technology, Gothenburg, Sweden

Construction planning and scheduling processes have been relatively unchanged until the last decades when 4D-planning has been promoted along with the rise of Building Information Modeling (BIM). Some 4D-systems have been developed for visualising schedules rather than to aid in the actual creation of the schedule. In contrast, some scheduling software in more recent years has been enhanced with 4D-modeling capabilities. Furthermore, the use of BIM-viewers during scheduling partly enables both design and schedule review before construction. This paper aims to show how an alternative approach to 4D-modelling could be used to produce schedules. The paper presents a prototype software for planning and scheduling where the production-schedule is created directly from the model in a lean construction Last Planner manner from the building components. Findings from evaluations of the prototype indicate a move of 4D-modelling from a passive visualisation to an active modelling process. This move enables knowledge to be created and exchanged in the social co-creation context of the 4D-schedule by the stakeholders. The co-creation and understanding can be further enhanced with the extension into virtual reality using head-mounted displays where the 4D-schedule can be created and reviewed directly.

KEYWORDS: 4D modelling, planning and scheduling, Collaborative work, Virtual reality

1. INTRODUCTION

Schedules are vital and are used throughout all the phases of a construction project. The most common way to use and communicate critical path schedules is by Gantt diagrams and linked bar charts (Baldwin & Bordoli, 2014, Chapter 1; Olivieri et al., 2019). Specialist planners or site managers often create the schedule. Thus, the schedule is based on general knowledge accumulated by the planner. However, it has been argued that site managers do not have enough time to spare to create quality schedules, and specialist planners may lack the more specialised knowledge to create high-quality schedules (Winch & Kelsey, 2005).

Furthermore, research has shown that the involvement of stakeholders, such as subcontractors and the ones executing the work, in the scheduling process removes the guesswork of planning and scheduling. Research also shows that involvement improves in buy-in into the schedule at all levels (Dvir, et al., 2003; Faniran et al., 1994; Laufer, 1992; Viklund Tallgren et al., 2015). Schedules are by nature a communicational as well as a managerial tool, but Gantt diagrams have been criticised, for example for not being able to convey spatial relations (Chavada, Dawood, & Kassem, 2012; Olivieri et al., 2019). It has also been argued that plans are often presented poorly with overly complicated information (Laufer & Tucker, 1987) and that plans are hard to interpret for persons not trained in scheduling techniques (Chrzanowski & Johnston, 1986; Mahalingam et al., 2010). The complexity of communicating information has justified alternative approaches to visualise the schedule, and one such method has emerged in 4D CAD technology and 4D modelling (Heesom & Mahdjoubi, 2004), which has gained firmer ground with the adoption of building information technology (BIM) (Boton et al., 2013). However, scheduling and modelling is often done in separate software's and thus needs to be linked in a 4D software. The literature shows that even though 4D shows promising advantages (Eastman et al., 2011), in for example the communication of the schedule, it still lacks widespread adoption (Crowther & Ajayi, 2019).

Literature also shows that the adoption of BIM has helped the construction industry to move towards more collaborative approaches (Crowther & Ajayi, 2019). This move is supported in the research of Viklund Tallgren (2018), Viklund Tallgren et al. (2020) and Johansson et al. (2014) and has also opened for a more visual approach to communication. Formoso et al. (2002) argue that visual communication increases the engagement of workers as well as their understanding of problems related to the project. The visual approach is further supported by Roupé et al. (2019) who reports that the use of virtual reality (VR) in the design phase allows stakeholders to understand the project better as well as to move from a passive interpreting role to a more active co-designing role. Thus, the stakeholders' tacit knowledge can be worked into the project directly by the stakeholders. Further, the use of VR lessens the risk for misinterpretation since there is less ambiguity in 3D compared to 2D drawings which rely on the user to visualise the 2D drawing for themselves (Roupé et al., 2019). The use of head-mounted displays (HMD) exemplifies how stakeholders could "step into" the model and experience the project in scale 1:1.

Thus, this paper identifies three main issues that it will address:

- **Planning and scheduling software are mostly aimed for expert planners;** thus, the software requires extensive knowledge and training to be effectively used.
- Planning and scheduling today offer **limited collaboration**, primarily through the creation phase.
- Traditional Gantt and linked bar charts offer **poor communication possibilities**, especially with workers on site.

This paper aims to analyse how the collaborative planning and scheduling approach presented within the article differs from the traditional 4D modelling approach. This analysis has been conducted by process modelling of a traditional planning and scheduling process together with an existing alternative collaborative planning approach. Furthermore, the traditional 4D modelling approach and the collaborative 4D modelling approach has also been analysed and process modelled. The use of process modelling, and especially the business process modelling notation (BPMN) is well established and used in the buildingSMART Alliance amongst others to provide a transparent and reproducible way to communicate process flows (Borrmann et al., 2018, Chapter 4). Furthermore, the paper illustrates how this alternative approach differs and addresses the three main issues during the scheduling process.

The paper begins with the analysis and description of the traditional planning approach as well as a traditional 4D approach and then the collaborative planning and scheduling approach. Then follows a short description of the method used in the paper, followed by the description of the enhanced collaborative planning and scheduling process that is web-based and uses BIM as well as VR. The web-based planning and scheduling tool has been presented in detail earlier without 4D visualisation, and VR implemented (Viklund Tallgren, 2018, 2020). Furthermore, the paper discusses how this tool addresses the issues stated earlier, and thus the paper contributes with:

- A comprehensive comparison between 4D modelling approaches
- The introduction of a user-friendly collaborative planning and scheduling tool
- Novel use of VR and HMD in the planning and scheduling phase.

The result shows how the traditional 4D modelling process can go from passive linking of a schedule and a 3D model to active 4D modelling as part of the collaborative planning and scheduling process.

2. PLANNING AND SCHEDULING PROCESSES

Traditional planning and scheduling processes can be described in several ways. This paper uses the planning process described by the project management institute (Jones, 2009). The general planning process is further extended with the workflow for site management and subcontractors according to findings in literature and interviews (Baldwin & Bordoli, 2014; Christiansen, 2012; Friblick & Nordlund, 2013). As seen in figure 1, the traditional planning and scheduling have three stakeholder groups, the project planner, site management and subcontractors. The project planner represents an active stakeholder, while site management and sub-contractors are passive concerning planning and scheduling. The project planner performs both the work breakdown structure (WBS) as well as the definition of work packages which breaks the WBS into distinct units or phases. Each work package is then planned by defining activities or tasks that are needed to complete a work package. When activities are defined, the hard logic of the schedule is defined. Hard logic is how activities depend on each other. The planner then inputs the schedule into a planning software such as Primavera, Powerproject, or Synchro, and once this is done, the logic is analysed, and errors corrected. The result is a draft schedule which is circulated to stakeholders. The draft schedule is reviewed with the stakeholders, working in the feedback into the schedule before it is finalised. As seen, the site manager has a more active role in the scheduling, but the subcontractors are mostly passive recipients of the schedule. In an interview with a project planner he stated that this was often a problem since he would have to push and “sell in” the schedule to gain acceptance for it, and even then, the subcontractors saw it merely as a loose guideline (Viklund Tallgren, 2018). Furthermore, literature also argues that more training is required to enable site management to engage more in the planning and make it more collaborative as well as lightening the planning load from the project manager (Crowther & Ajayi, 2019).

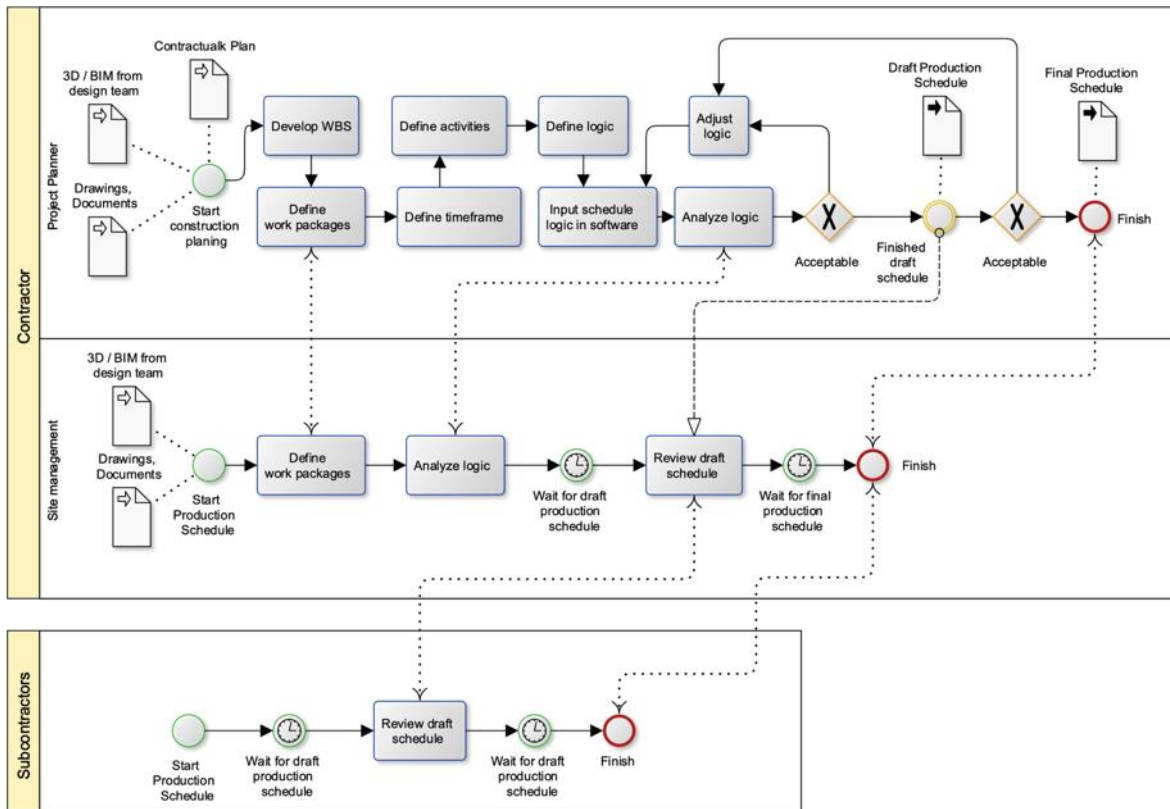


Figure 1: Traditional planning process.

2.1 Traditional 4D planning

The traditional 4D planning approach is well document in literature, and two main approaches have been identified. One is manual stitching of pictures of a 3D model representing stages in the production process which results in a movie that can be played back (Baldwin & Bordoli, 2014, Chapter 9; Eastman et al., 2011). Manual stitching was typical before the introduction of BIM and is the most passive 4D approach. The other approach is a more interactive one where the schedule and the BIM model is linked (Baldwin & Bordoli, 2014, Chapter 9; Crowther & Ajayi, 2019). The most common way to achieve the second approach to 4D visualisation is to conduct the traditional planning and scheduling process as business as usual, indicated in figure 2 in the lower swimlane as a subprocess for stakeholders such as the project planner as described in the general planning and scheduling process. The complete schedule is then given to a BIM specialist like a BIM coordinator who merges the schedule and the models. As seen in the upper swimlane in figure 2, this linking is prepended with two separate preparatory paths. One path is the input of the 3D data / BIM model into the 4D software, and the re-organisation and grouping of components according to the construction strategy, the other is the preparation of the construction schedule by importing it and setting up activity types for visual behaviour to visualise the construction process. This preparation could be done by coding the objects or utilising grouping of objects.

Similarly, the schedule is imported, then the visual behaviour is defined, usually to indicate visual behaviour for objects of activities that are existing, being built, finished, temporary or demolished. After the preparations, the BIM coordinator works through the activities, linking components from the model to the schedule. Once all components are linked, and additional temporary tasks modelled, the 4D visualisation can be produced. The 4D visualisation is done either as a movie or as an interactive model. As seen here, specialist competence is needed to produce 4D visualisations. One reason for this is the need for a good understanding of the information structure in the 3D / BIM model as well as knowledge of the 4D systems, which often are more advanced than standard scheduling software.

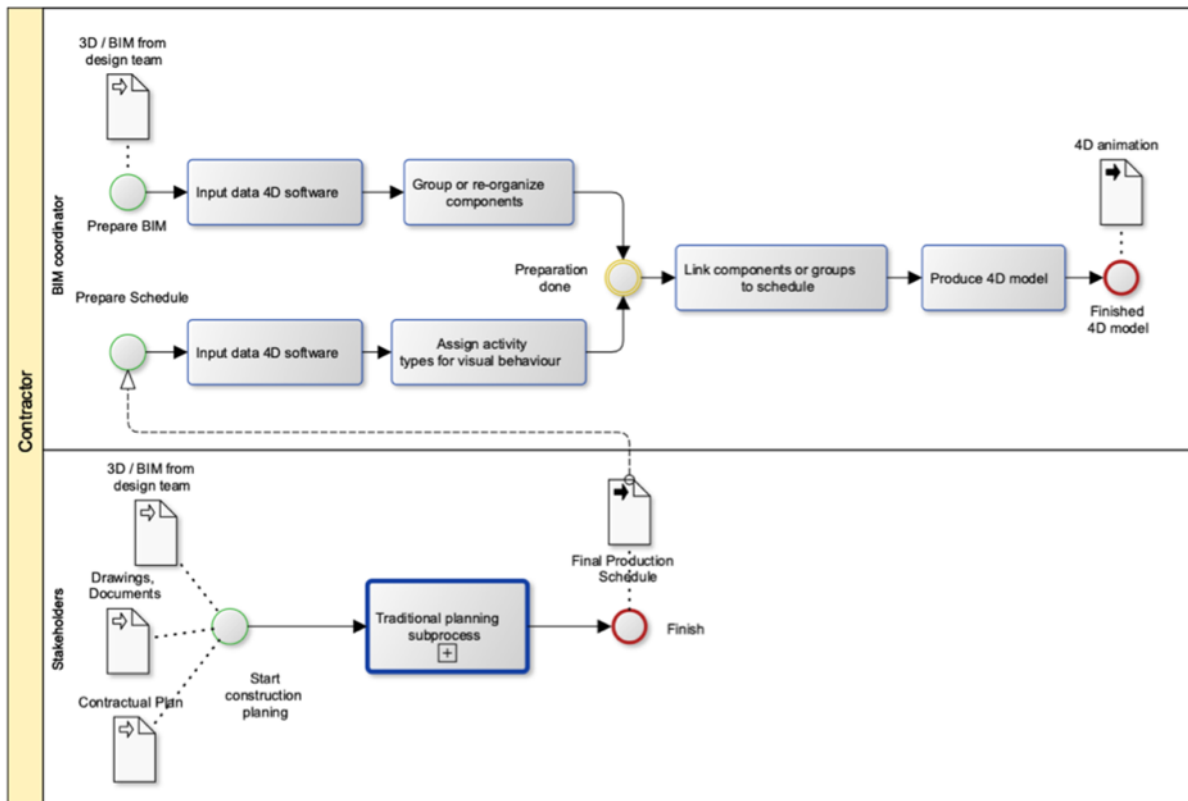


Figure 2: Traditional 4D modelling process.

2.2 Collaborative planning and scheduling

The collaborative planning process described here is defined in Viklund Tallgren (2018), and further elaborated in Viklund Tallgren et al. (2020) and builds upon the collaborative planning, and scheduling approach developed during the late eighties and early nineties (Friblick & Nordlund, 2013; Söderberg, 2006). In Scandinavia, these approaches were driven by the union and with a strong belief in co-determination and flatter hierarchies, leading to workers or at least the supervisors from the different subcontractors participating in the planning and scheduling process (Söderberg, 2006). This approach has similarities to the Last planner approach but is not as strict in the use of pull planning vs push planning and the use of specific schedule visualisation techniques (Friblick & Nordlund, 2013).

The main difference is that the planner does not actively plan; thus, the planner does not define activities or the hard logic of the schedule. Instead, the planner acts as a moderator during the sequencing of the activities. Figure 3 shows the basic layout of the collaborative planning process. The main difference compared with the traditional planning process in figure 1 is that the project planner works closely with the site management in defining work packages. These work packages are then used during the collaborative planning workshop to limit the scope of the scheduling. One work package is planned and scheduled at a time. This is illustrated by an individual planning process, shown in Figure 4. This move of responsibilities is the main difference to traditional planning. Supervisors from the site management and subcontractors respectively are responsible for planning their specific activities, thus moving the planning and scheduling from the expert planner to the ones performing the work. The observations of these workshops show that much of this activity definition is done during the scheduling workshop while actively communicating with closely connected disciplines, thus minimising the risk for misinterpreting other disciplines work. Activities are created on sticky notes, one activity per sticky note, with name, resources, duration, and location stated. This process is similar for subcontractors as well as for site management, who plans the general works to be conducted in each work package. Once all activities in a work package are defined, the sequencing of the schedule starts. The sequencing work is the switch from independent individual planning work to collaborative scheduling work. This is illustrated in figure 5. The observations show that the project planner takes more of a managing role in seeing that all stakeholders share knowledge and define the best possible sequence for the work package at hand. All stakeholders are responsible for their activities, as well as adding their sticky notes to the big sheet of paper representing the current work package at an agreed-upon sequence. This sequencing

goes on until all activities are sequenced and all hard logic defined.

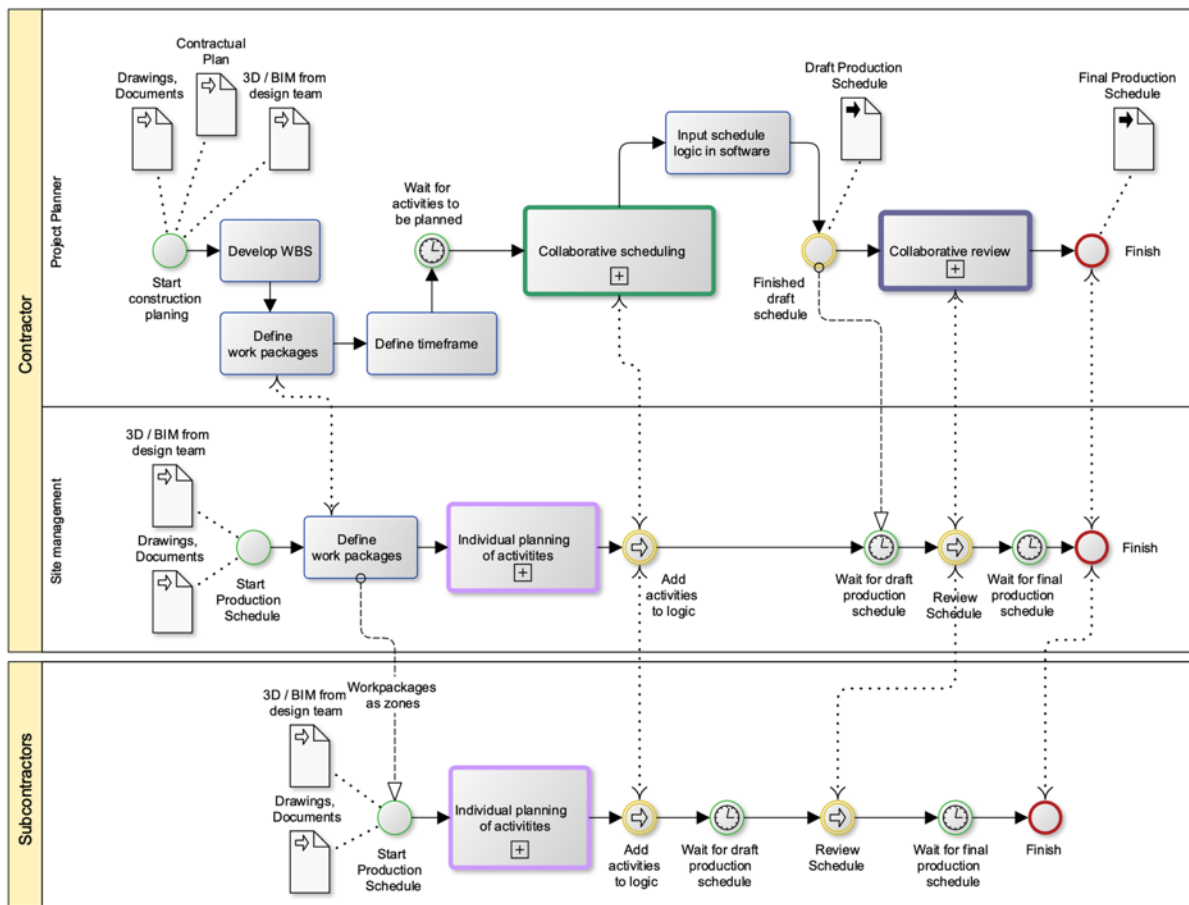


Figure 3: General collaborative planning process.

Observations conducted during such workshops shows that some constructability issues can be identified and fed back to the design team, thus rectifying issues before they start the construction (Viklund Tallgren et al. 2020). Once this is done, the Project planner reviews and analyses the schedule together with the stakeholders to identify potential problems or errors; this is shown in more detail in the collaborative review subprocess in figure 6. Here the observations showed that to some extent some rework of the logic was done, and information on activities were supplemented, and sometimes even new activities added. This addition usually meant substantial rework of the logic. Thus, as a first draft, a pencil was used to draw connections. Once the schedule logic was finalised, the logic was permanented markers. During discussions with project planners from several Scandinavian construction companies, some mentioned that they used whiteboards instead of paper to record the logic, then photographing the finalised logic (Viklund Tallgren 2018; Viklund Tallgren et al. 2020).

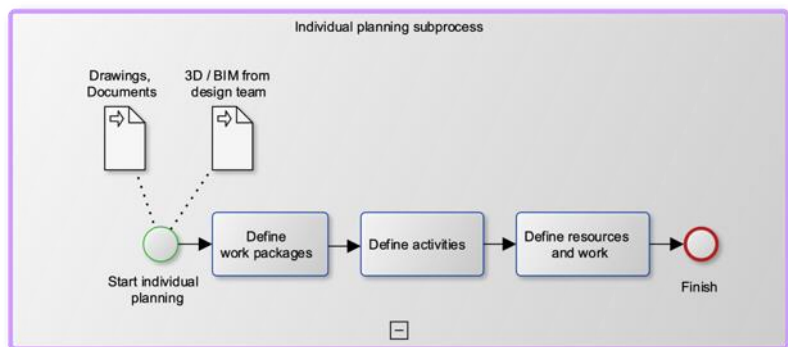


Figure 4: Individual planning subprocess.

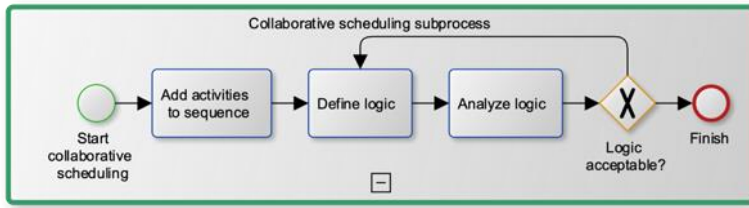


Figure 5: Collaborative scheduling subprocess.

Once all the work packages are worked through similarly, the project planner takes the sheets of papers and records the schedule in scheduling software. Observations and interviews have shown that the number of projects the project planner is responsible for affects the time possibility to finalise the work, which could take up to a couple of weeks. The planner mentioned that errors in the logic are common in the physical plan (Viklund Tallgren 2018; Viklund Tallgren et al. 2020). These errors are often identified during input in the software, which leads to the planner drawing assumptions to solve the errors. The resulting schedule is typically an idealised schedule that needs to be optimised to adhere to the contractual plan. The un-optimised schedule creates the need for a follow-up workshop. During the follow-up workshop, the draft schedule is collectively reviewed, and hard logic is suitably adjusted until the timeframe of the schedule coincides with the contractual plan. In an interview with the planner, he mentioned that the philosophy behind this approach is to let the group initially be free from time constraints and thus being able to focus on hard logic such as the right sequences and relations between activities (Viklund Tallgren, 2018). Thus, optimisation can be done in a second step, once the logic is in place. The project planner reworks the schedule and the logic adjusted and agreed upon before a final schedule is produced and then sent out to all stakeholders.

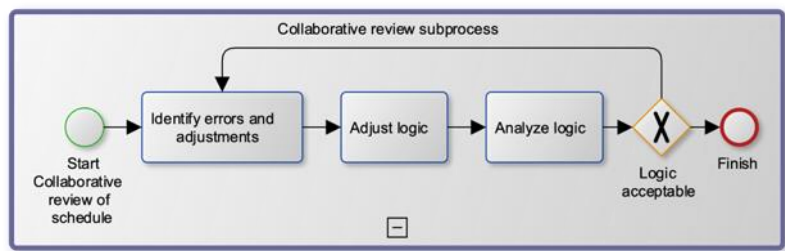


Figure 6: Collaborative review subprocess.

3. METHOD

The research presented in this paper is a part of a larger research project, where design science (DS) has been used as the overarching research framework. The basis is a practice-based problem, linked to the body of knowledge of the field as well as in-situ observations. DS as an approach is broadly defined as consisting of three activities, Design, Build and Evaluate, all of which are interrelated (Hevner et al., 2004). The data in this paper is compiled from observations, field notes, interviews and evaluations performed in the broader research context. In total, seven scheduling workshop observations with four different projects, seven interviews with nine workers and managers, as well as 14 prototype evaluations have been conducted (Roupé et al. 2014, Viklund Tallgren et al. 2015; Viklund Tallgren 2018; Viklund Tallgren et al. 2020).

The projects were selected because of their use of the collaborative planning approach described in Section 2.2. The projects were observed in their natural setting, with as little disturbance as possible. All workshop was observed as business as usual, and after the initial short presentation, the participants quickly went about the workshop at hand, ignoring the researcher. All but the first workshop was recorded with video and sound to ease the capture of interactions and communication. All workshops were documented with field notes that were thematically coded and analysed.

All but one interview was conducted as semi-structured interviews, where an interview guide helped guide the interviews around the information need during construction planning and scheduling. The last interview was conducted as an unstructured interview. The last interview aimed at capturing the project planners' approach to planning and scheduling in general and especially regarding the collaborative planning approach that he was pushing onto the projects for which he is responsible.

The 14 prototype evaluations focused on the usability and fit of the developed tool for the collaborative planning and scheduling process. Four of these evaluations were small informal evaluations with the closest research group to test functionality. Seven evaluations were to test the process and evaluate against best practice, conducted with groups of middle managers, BIM coordinators and project planners from Scandinavia's five major construction companies. Three evaluations validated the tool against the process and were conducted with construction management students, knowledgeable in the collaborate planning method. A more in-depth description of the approach to the primary data collection can be found in Viklund Tallgren (2018), where all but the last two

observations, and the three evaluations with BIM coordinators and project planners are covered. The collected data has been recorded and transcribed, then thematically coded with Nvivo 12.

The analysis and modelling of processes have proved to be an effective way to compare and communicate processes as well as to specifying software system requirements (Aram et al., 2010; Ouyang et al., 2009). This paper uses the four-step approach defined by Saluja (2009) to model the process:

1. Identify the set of activities that make up a particular task;
2. Identify the agent(s) involved;
3. Identify the intermediate and end goal for the task; and
4. Identify what resources will be referred to or used for the completion of the task.

However, the paper uses the original BPMN notation rather than the layout presented in Saluja (2009). Furthermore, a literature review, observations and the interview with the project planner has been the basis for the process modelling of the planning and scheduling approaches.

4. THE VIRTUAL PROJECT PLANNING SYSTEM FOR PLANNING AND VISUALISATION

The virtual project planning system (VPP) is the extension of the collaborative planning and scheduling method described in subsection 2.2, figure 3. However, it enhances it with a BIM-based web-interface for each stakeholder to plan and schedule their activities. Figure 7 illustrates the steps of the web-interface connected to the VPP system for the enhanced collaborative planning and scheduling process, where the BIM model is used as the information carrier and a schedule as well as a 4D visualisation is the outcome of the collaborative planning and scheduling process. The development of this process is described in more detail in Viklund Tallgren (2018) and is used to describe the process model seen in figure 8. The user interface has been developed during iterative evaluations in collaboration with the construction industry, as described in the method section. The goal has been to keep the process as close as possible to the traditional collaborative planning and scheduling process while still having a user-friendly interface. The primary process is modelled on the collaborative planning process in figure 3. However, all stakeholders interact with the BIM model therein to create activities rather than physical sticky notes and thus results in the process seen in figure 8.

Since the system is web-based, it requires the BIM model to be uploaded to the VPP system. Preferably somebody with the project responsibility does this, such as the project planner, project manager or a BIM coordinator. Similarly, as in the traditional 4D modelling process in figure 2, there is a need to define the WBS and work packages in the form of locations. This process is done already in the design phase through the coding and classification according to the delivery manual. Thus, the classification and coding resemble the grouping of parts grouping parts that is done in the preparation stages of the traditional 4D modelling process in figure 2. The classification and coding system used in the model helps to filter the model disciplines according to subcontractors.

Once the model is in the VPP system, the collaborative planning and scheduling workshop can take place. Each discipline creates its activities by selecting components of the BIM model. These components make up an activity, and the user put in name, resources and duration in the activity, see the middle part of figure 7, marked individual planning. These digital activities replace the sticky note and enable the user to get information directly from the objects that are part of the activity. Thus, the activity is connected to the model already in the creation-phase of the activities.

The sequencing of the logic is done as described earlier in figure 3, collaboratively. However, instead of physical sticky notes, each stakeholder drags and drops the activity to the work package schedule and connects it with the logic that is needed, see the lower part of figure 7, the collaborative scheduling and review. In the background, the system calculates the critical path as well as work package duration based on the duration of the logic and critical activities. The result is an instantly reviewable schedule. Evaluations of the VPP system with participants experienced in the sticky-note version of the collaborative planning method mentioned that the VPP system was more natural to grasp (Viklund Tallgren et al. 2020). Mainly because the overview of schedule was the better and the ease in adjusting the schedule compared to the physical sticky notes and arrows on big sheets on paper. The possibility to easily rearrange and adjust connections between activities were especially appreciated.

A difference with the VPP system compared to the traditional 4D modelling process is that the 4D modelling is created continuously as the project is planned and scheduled. A 4D visualisation becomes an additional result along with the schedule once the sequencing is done. Using the 4D visualisation to review the schedule during all parts of the sequencing can eliminate the need for waiting to document the schedule in the scheduling software. See the bottom of figure 7 for the collaborative scheduling view and 4D review view. Hard logic can be reviewed continuously if uncertainties of the best sequence should arise. The ability to instantly review the schedule reduces the lead time between the workshop and the completed schedule. The resulting schedule can be exported to a scheduling software in a matter of minutes, and the project planner can bring up and make the final edits in the workshop before concluding the workshop, thus shortening the time from workshop to finished and agreed upon production schedule.

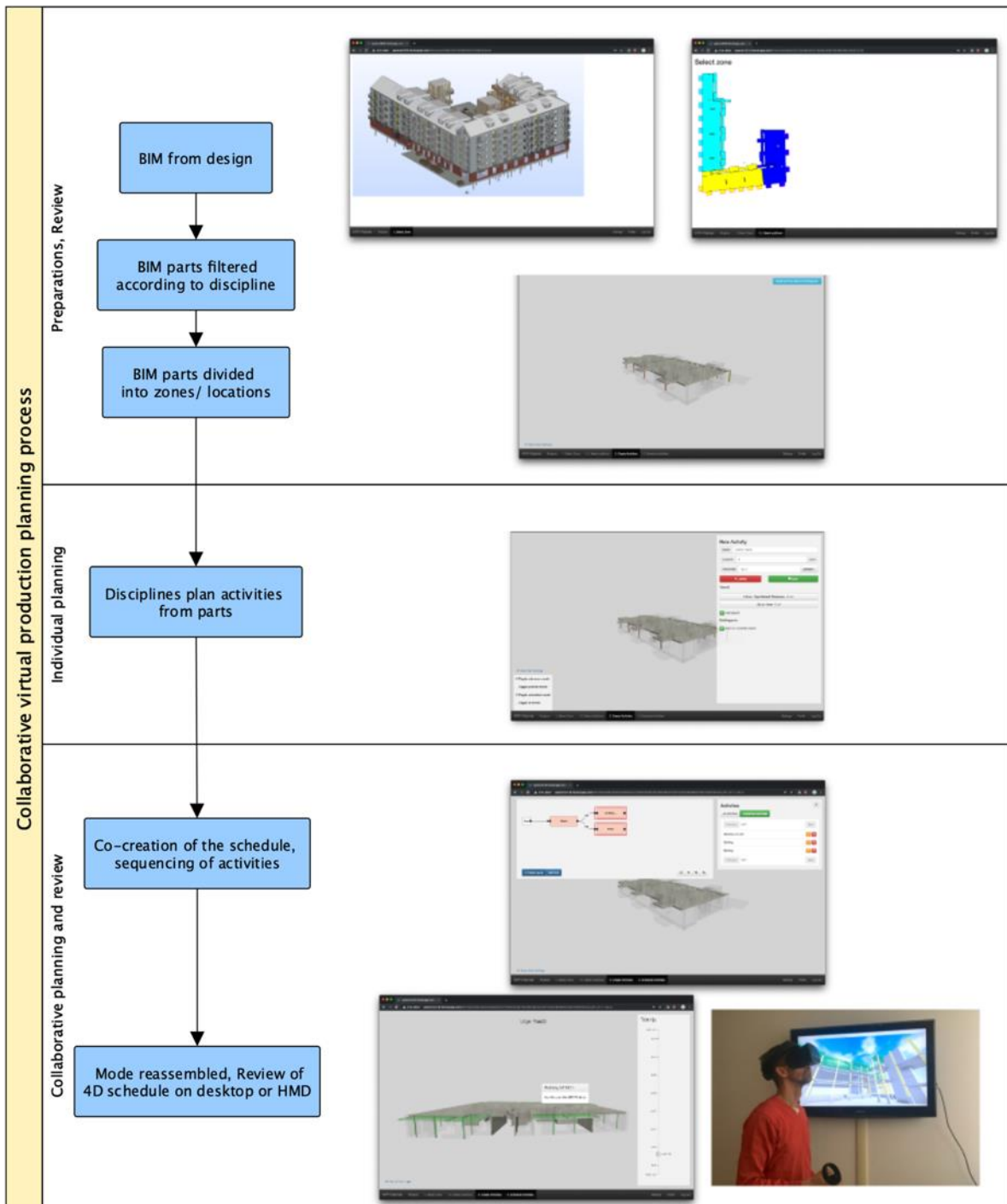


Figure 7: VPP 4D approach.

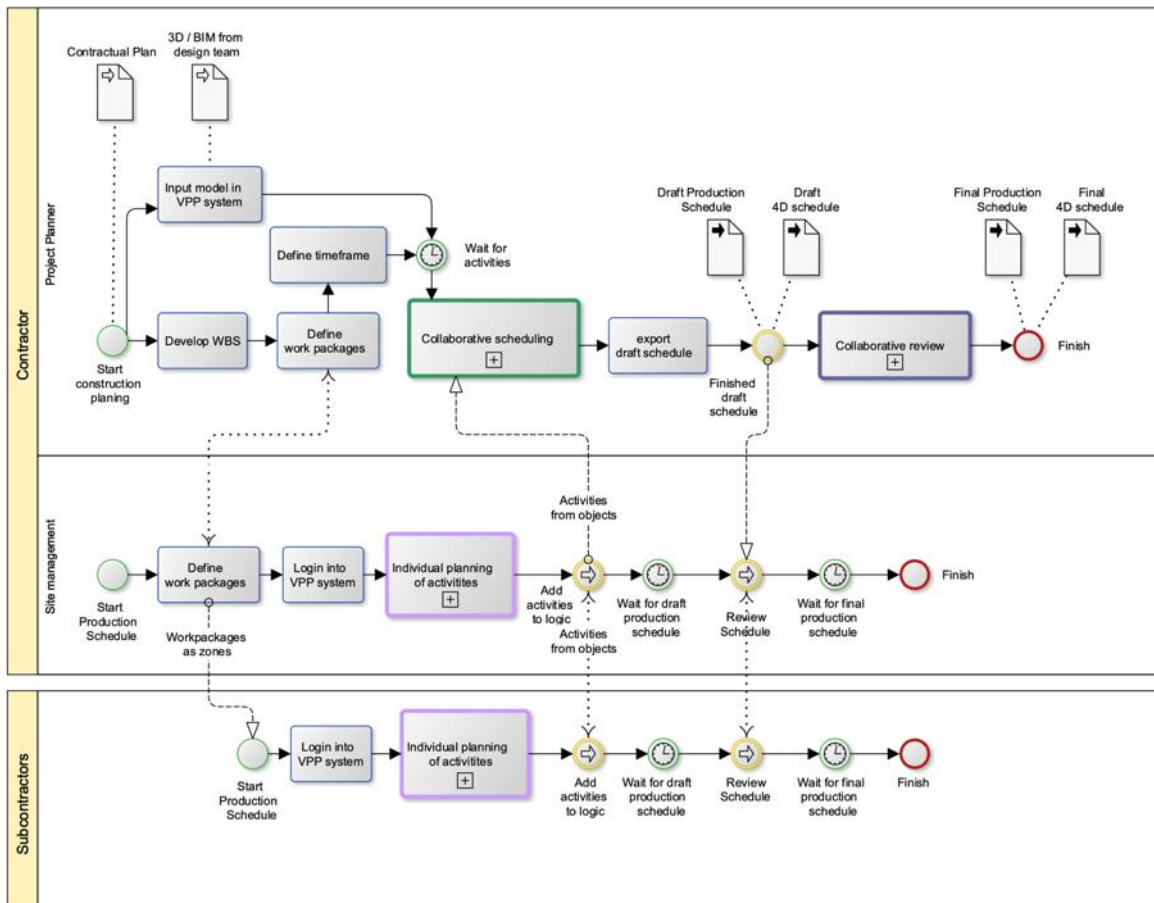


Figure 8: Enhanced VPP process, for details of Individual planning subprocess, see Figure 4, Collaborative scheduling subprocess see Figure 5 and for Collaborative review subprocess see Figure 6.

4.1 Extension into VR

Since the VPP system was designed with a web interface that uses an application program interface (API) to communicate with the server, it enables connecting other interfaces as well. Since the web interface is somewhat limited concerning the size of the model it can handle, another tool called BIMXplorer (Johansson, 2016) is used to visualise the full model. The connection between tools is facilitated by a WebSocket communication protocol, which means that the VPP system can connect to one or several BIMXplorer clients. Thus, the workshop participants can utilise BIMXplorer to review the 4D-schedule in scale 1:1 in an HMD, as seen in figure 9. The 4D-capabilities in VR is realised by setting the visible state of objects according to the schedule. The VR-client loads the same BIM as is used in the VPP system, and then registers for notifications from the VPP-server. With each object in the BIM having a Globally Unique Identifier (GUID), the VPP-server only needs to send the GUID together with a boolean indicating visible/invisible state to update the VR-model according to the schedule. The change of the 4D time-slider broadcasts a list with the affected GUIDs to any connected clients. The clients use the list to update the visible state of the corresponding objects in the client. When in VR, participants can freely navigate around in the BIM in scale 1:1 and take distance measurements and query objects for properties in the same way as previously described in Johansson & Roupé (2019).



Figure 9: A site manager reviewing the 4D visualisation in an HMD.

5. DISCUSSION AND CONCLUSIONS

This paper has presented and compared a collaborative planning and scheduling method (e.g. VPP) with traditional 4D scheduling using process modelling (BPMN). The result and analyses of the process modelling show that traditional 4D method relies on existing schedules produced by specialist planners in cooperation with BIM-coordinators and often has limited support for collaboration, primarily through the creation phase. There is a need for a more user-friendly interface since traditional 4D systems are often complex and specialist competence is needed to produce the 4D visualisation, as seen in the analysis of the traditional 4D process. Furthermore, traditionally the 4D model is mainly used for reviewing the existing construction schedule in 3D. These types of reviews have shown to increase the understanding of the schedule and have been effectively used as a passive visual communication tool of the construction schedule. However, the traditional 4D modelling process is limited when it comes to collaboration during the creation phase of the schedule.

We argue that by using the presented collaborative planning and scheduling method and the VPP system instead of traditional 4D-scheduling, it is possible to support and enable co-creation in a more user-friendly interface. Thus, it is possible to increase engagement of workers and subcontractors and let the ones executing the construction work, plan and schedule in 4D. The outcome from this process removes the guesswork from the project planners work and improves empowerment and buy-in into the schedule at all levels, which has been a highlighted issue then it comes to scheduling (Dvir et al., 2003; Faniran et al., 1994; Laufer, 1992; Viklund Tallgren et al., 2015). The process modelling (BPMN) also reveals how the traditional 4D scheduling process can go from being a passive process of linking the prepared schedule and with a 3D model, to become an active and socially creative 4D modelling process. This social creativity is achieved by using the VPP-system and the collaborative planning and scheduling method. By supporting this collaborative process, it is possible to provide opportunities and resources for activities embedded in a social, creative process in which all stakeholders can actively contribute rather than having passive receiving roles. The VPP collaborative scheduling can enable co-creation and creates a shared understanding were the participants create awareness of each other's work and provide mechanisms to help draw out the tacit knowledge during negotiation and communication about how to plan and conduct the project. The use of multiple representations and visualisations gives the participants the possibility to understand different points of view and different subtasks of the project and further enhances the understanding of the project.

Furthermore, with the possibility to also support 4D visualisation in immersive VR, the construction workers and

subcontractors are enabled to “step into” a 4D-schedule and experience and review the scheduled sequences in 1:1 scale. VR has shown to give a much better understanding of the project, and since “everyone sees the same thing” with VR in contrast to drawings, VR is predicted to facilitate communication between different parties as it reduces the risk of misinterpretations, according to Johansson & Roupé (2019). The 4D visualisation in immersive VR could thus be argued to support better design and constructability review of the construction. Also, as the 4D visualisation in immersive VR is seamlessly integrated with the VPP-system, it is possible to do changes in the 4D schedule in the web-based scheduling interface, and have the changes instantly updated in VR. The integration supports a better interactive design and review of the 4D schedule and construction. As the 4D is not static, it promotes co-creation in different spaces and could give a better understanding of different points of view and different subtasks between different sub-contractors.

In the future, it would be interesting to explore and evaluate if VR also could be valuable and used as an interactive interface during the actual VPP process. By seamlessly integrating the same tools and processes as the VPP-system supports today, it would be possible to explore and work with the planning and scheduling in different virtual spaces. Thus, the possibility to support multiple representations and visualisations give the participants new ways to understand different subtasks. For example, the *Individual planning subprocess*, described in figure 4, could be performed in VR. During that process, the user selects and groups BIM components into defining activities or tasks that are needed to complete a work package.

Furthermore, the *Collaborative scheduling subprocess*, described in figure 5, could also be conducted in different spaces, for example, immersive VR. An example could be the projector displaying the environment along with the client views. However, space could also be different physical locations. In this context, the VR interface could maybe be a more natural user interface and give a better understanding when it comes to creating activities and scheduled sequences in 1:1 scale. The VR interface could also help review and identify worksite safety problems more intuitively.

6. REFERENCES

- Aram, S., Eastman, C., Sacks, R., Panushev, I., & Venugopal, M. (2010). Introducing a New Methodology to Develop the Information Delivery Manual for AEC Projects. *Exchange Organizational Behavior Teaching Journal*, (Nibs 2008), 16–18.
- Baldwin, A., & Bordoli, D. (2014). *Handbook for construction planning and scheduling*. John Wiley & Sons.
- Borrmann, A., König, M., Koch, C., & Beetz, J. (2018). Building information modeling: Why? What? How? In *Building Information Modeling: Technology Foundations and Industry Practice*. https://doi.org/10.1007/978-3-319-92862-3_1
- Boton, C., Kubicki, S., & Halin, G. (2013). Designing adapted visualisation for collaborative 4D applications. *Automation in Construction*, 36(0), 152–167. <https://doi.org/10.1016/j.autcon.2013.09.003>
- Chavada, R., Dawood, N., & Kassem, M. (2012). Construction workspace management: The development and application of a novel nD planning approach and tool. *Journal of Information Technology in Construction*, 17, 213–236.
- Christiansen, F. (2012). *The Planning Process at a Construction Site*. Chalmers University of Technology.
- Chrzanowski, E. N., & Johnston, D. W. (1986). Application of linear scheduling. *Journal of Construction Engineering and Management*, 112(4), 476–491. [https://doi.org/10.1061/\(ASCE\)0733-9364\(1986\)112:4\(476\)](https://doi.org/10.1061/(ASCE)0733-9364(1986)112:4(476))
- Crowther, J., & Ajayi, S. O. (2019). Impacts of 4D BIM on construction project performance. *International Journal of Construction Management*, 0(0), 1–14. <https://doi.org/10.1080/15623599.2019.1580832>
- Dvir, D., Raz, T., & Shenhar, A. J. (2003). An empirical analysis of the relationship between project planning and project success. *International Journal of Project Management*, 21(2), 89–95.
- Eastman, C., Teicholz, P., Sacks, R., & Liston, K. (2011). *BIM handbook: A guide to building information modeling for owners, managers, designers, engineers and contractors*. John Wiley & Sons.
- Faniran, O. O., Oluwoye, J. O., & Lenard, D. (1994). Effective construction planning. *Construction Management and Economics*, 12(6), 485–499.

- Formoso, C. T., dos Santos, A., & Powell, J. A. (2002). An exploratory study on the applicability of process transparency in construction sites. *Journal of Construction Research*, 3(01), 35–54.
- Friblick, F., & Nordlund, T. (2013). Framgångsrik planering i byggprojekt.
- Heesom, D., & Mahdjoubi, L. (2004). Trends of 4D CAD applications for construction planning. *Construction Management and Economics*, 22(22), 171–182. <https://doi.org/10.1080/0144619042000201376>
- Hevner, A. R., March, S. T., Park, J., & Ram, S. (2004). Design science in information systems research. *MIS Quarterly*, 28(1), 75–105.
- Johansson, M. (2016). From BIM to VR - The design and development of BIMXplorer. Chalmers University of Technology.
- Johansson, M., & Roupé, M. (2019). BIM and Virtual Reality (VR) at the construction site. Proceedings of the 19th International Conference on Construction Applications of Virtual Reality. Bangkok, Thailand.
- Johansson, M., Roupé, M., & Viklund Tallgren, M. (2014). From BIM to VR-Integrating immersive visualisations in the current design process. Fusion-Proceedings of the 32nd ECAADe Conference-Volume 2 (ECAADe 2014), 261–269.
- Jones, E. F. (2009). Scheduling 101 - the basic of best practices. Orlando: Project Management Institute, Inc.
- Laufer, A. (1992). A micro view of the project planning process. *Construction Management and Economics*, 10(1), 31–43.
- Laufer, A., & Tucker, R. L. (1987). Is construction project planning really doing its job? A critical examination of focus, role and process. *Construction Management and Economics*, 5(3), 243–266.
- Mahalingam, A., Kashyap, R., & Mahajan, C. (2010). An evaluation of the applicability of 4D CAD on construction projects. *Automation in Construction*, 19(2), 148–159. <https://doi.org/10.1016/j.autcon.2009.11.015>
- Olivieri, H., Seppänen, O., Alves, T. D. C. L., Scala, N. M., Schiavone, V., Liu, M., & Granja, A. D. (2019). Survey Comparing Critical Path Method, Last Planner System, and Location-Based Techniques. *Journal of Construction Engineering and Management*, 145(12). [https://doi.org/10.1061/\(ASCE\)CO.1943-7862.0001644](https://doi.org/10.1061/(ASCE)CO.1943-7862.0001644)
- Ouyang, C., Dumas, M., Van Der Aalst, W. M. P., Ter Hofstede, A. H. M., & Mendling, J. (2009). From Business Process Models to Process-Oriented Software Systems. *ACM Transactions on Software Engineering and Methodology*, 19(1), 1–37. <https://doi.org/10.1145/1555392.1555395>
- Roupé, M., Johansson, M., Maftai, L., Lundstedt, R., & Viklund-Tallgren, M. (2019). Seamless Integration of Multi-touch Table and Immersive VR for Collaborative Design. *Advances in Informatics and Computing in Civil and Construction Engineering*, 263–270. https://doi.org/10.1007/978-3-030-00220-6_32
- Roupé, M., Viklund, Tallgren, M., Johansson, M., & Anderson R. (2014) Virtuallproduktionsplanering med hjälp av BIM och visualisering. SBUF Rapport 12851. Göteborg.
- Saluja, C. (2009). A process mapping procedure for planning building information modeling (BIM) execution on a building construction project. *Architectural Engineering*.
- Söderberg, J. (2006). Concordia – försök med integrerad planering. Lund.
- Viklund Tallgren, M. (2018). Developing a collaborative planning tool for construction - A Building Information Model-enhanced planning and scheduling tool for production. Chalmers University of Technology.
- Viklund Tallgren M, Roupé M, Johansson M, & Bosch-Sijtsema P. (2020) BIM tool development enhancing collaborative scheduling for pre-construction. *Journal of Information Technology in Construction* 25: 374–397. DOI: 10.36680/j.itcon.2020.022.
- Viklund Tallgren, M., Roupé, M., & Johansson, M. (2015). An empowered collaborative planning method in a Swedish construction company - A case study. 31st Annual ARCOM Conference, 793–802. Association of Researchers in Construction Management.

Winch, G. M., & Kelsey, J. (2005). What do construction project planners do? *International Journal of Project Management*, 23(2), 141–149. <https://doi.org/https://doi.org/10.1016/j.ijproman.2004.06.002>

VIRTUAL REALITY IN CONSTRUCTION HEALTH AND SAFETY EDUCATION: STUDENTS EXPERIENCE THROUGH VIDEO ELICITATION - A PILOT STUDY

Mark Swallow

Leeds College of Building, Leeds

Sam Zulu

Leeds Beckett University, Leeds

ABSTRACT:

Health and safety education and training has long been considered a passive and unengaging experience, mainly relying on conventional lecture based delivery. Due to substantial technological advancements, virtual reality is now an available and affordable tool. This presents exciting opportunities for industry and education providers alike to exploit this technology with a view to improve training. Previous research explored the potential for VR to improve training and the users experience. These predominantly utilised conventional interviews and questionnaire methods to collect data to draw their conclusions. In this pilot study a video elicitation interview technique was adopted combined with the use of virtual reality (VR). Using this combined method, the study aimed to explore the reflective experience of higher education students using VR specifically for health and safety education/training. Although the use of video elicitation interviews is a method to collect qualitative data, it was found that when combined with VR it could in fact provide an effective approach to learning. By capturing this interaction it provided opportunities for students to re-visit and debate through discussion, prompted by the video footage. This allowed them to draw on their recaptured experience with the opportunity to examine and rethink their planning outside of the virtual environment. The combined use of VR and video elicitation assisted students in describing their planned approaches to safety management. Practically applied alongside conventional methods this could provide architectural, engineering and construction students with an engaging risk free training process with the added ability to replay and discuss the interaction.

KEYWORDS: *construction, safety, training, video elicitation interviews, virtual reality*

1. INTRODUCTION

Education and training plays an essential role in developing the knowledge and skills required to plan and manage construction activities whilst considering safety (Lin et al., 2011). Currently, safety training aimed at those in commercial or site managerial roles within the architectural, engineering and construction (AEC) disciplines tends to adopt the conventional lecture style delivery. This approach lacks the hands on training required (Guo et al., 2012) and often uses passive methods, which although may contain the information, is not engaging to students (Gheisari & Esmaeili, 2019; Pedro et al., 2015). With enthusiasm surrounding virtual reality (VR) (Chevin, 2018) training providers and industry alike have been actively exploiting this tool for safety training purposes. As such, many researchers have explored the potential of VR over more conventional means of improving training (Sacks et al., 2013). This includes its impact on risk perception, hazard identification (Perlman et al., 2014) and considered its potential for safety within design (Sacks et al., 2015). Whilst these studies have begun to investigate the value of VR and its effectiveness on these aspects, they tend to adopt experimental methodologies. These often involve using pre-tests and post-tests, which although useful do not encourage reflective behaviour to embed learning. Within previous studies, researchers have also opted to involve standard interview techniques as part of their methodology (Lu & Davis, 2018; Sacks et al., 2013; Sacks et al., 2015; Shi et al., 2018). Although the various advantages of VR for safety training are clear (Guo et al., 2012; Le et al., 2014) further focus on the interview techniques to draw out the reflective impact on learning is an area yet to be explored. A proven method in supporting this aim is video elicitation.

According to Henry & Fetters (2012, p. 121) video elicitation interviews are used to “facilitate investigation of specific events during interactions and fluctuations in participants’ thoughts and feelings within a single

interaction". The method allows for accurate recall of events and the participants thoughts, which may otherwise have been forgotten. By capturing a video recording of the interaction this allows participants to notice new aspects missed during the initial interaction. This can assist in further discussion and reflective practice. Although the use of video elicitation to support training has been explored in many sectors including healthcare (Henry et al., 2011) and sports (Morgan, 2015), there is little evidence of this method within architecture, engineering or construction disciplines. Furthermore there is a lack of exploration between the combined use of video elicitation methods and virtual reality. Therefore, the main aim of this pilot study is to test the use of video elicitation within the context of construction that focuses on health and safety training using VR. The study will assess the effectiveness of this method and explore the combination of this with the use of VR. This study seeks to provide a base for integrating the use of video elicitation in this field and also present a unique insight to the experience of higher education students in using the VR tools for safety training.

1.1 Using Virtual Reality for Safety Education and Training

Current research has concluded that the use of immersive technology can provide a risk free environment for students which offers an ideal solution for safety training (Hafsia et al., 2018; Jeelani et al., 2017). To date, researchers have examined the feasibility of using VR for safety training in the AEC sector. This has looked at testing its efficiency in addition to exploring the users experiences and perceptions. For example, Sacks et al. (2013) used pre and post-tests to explore the effectiveness of VR when compared to conventional learning methods. Their results considered VR as a more effective learning experience. They observed an improvement in concentration and engagement over its traditional counterpart. The results using pre and post-tests not only showed a positive perception of VR but also significant improvement of student test scores. Shi (2018) also researched users experience of VR focusing on behaviour. In this study, the researcher conducted interviews to collect qualitative data following their interaction. By asking open questions concerning their feelings and how the other users effected their behaviour, the feedback reported that the VR provided a realistic experience. However the study also identified the importance of the quality of the equipment, including how calibration accuracy can have an effect on the feeling of 'presence'.

Jeelani et al. (2017) aimed to develop an immersive training environment for delivering personalised three-phase hazard recognition training. This virtual environment utilised 360° panoramic images and 360° walk through videos from construction sites via the use of head mounted displays (HMDs). Having developed the virtual environment, the validation from those who underwent training were designed in the form of questionnaires. The feedback reported a high degree of realism and recommended the use of immersive environments to enhance delivery of training modules. Park et al. (2015) proposed a framework for mobile based VR and augmented reality (AR), designed for experiential learning. This focused on learner safety knowledge, reflection and evaluation. This study used interview questionnaires to evaluate the system, based on 5-point Likert scale. The results indicated students found the usability and effectiveness assisted with safety cognition and recall. Like in the findings of Jeelnai (2017) the importance of providing a realistic visual representation of site conditions were identified in order to provide the feeling of 'presence'. These studies highlighted the clear advantages of VR in safety training however exploring the participants reflective experience during the interaction were overlooked.

1.2 Video Elicitation

Developing the most effective approach to training remains a topic of much debate. This is often influenced by the specific topic and the needs or style of the learners. The use of media to assist in training has become a common tool, whether this be in the use of images, sound or video to support delivery and spark discussion. The use of video elicitation has been explored in a number of sectors. For example in sport Morgan (2015) explored combining this method with teaching games for understanding coaching intervention on tactical decision making. The combined method showed both an increase in tactical decision-making and engagement. Within healthcare, research by Henry & Fetters (2012) used video elicitation to investigate physician-patient interaction. They identified that although time consuming, this method allowed a more accurate recall of events. This offered opportunities for participants to notice new aspects after the initial interaction. This identified the method to be "most useful for investigating social or interactional components of physician-patient interactions that cannot be adequately understood by either direct observation (eg, video recordings) or interviews alone". Also in healthcare, Vieira (2014) aimed to identify risks for transfer-related falls and risk reduction strategies using the video elicitation method. The results found this to be useful in this setting, suggesting further use in future studies.

Jewitt (2012) recommends that video elicitation can be used as a basis for reflection on practice. Sewall (2009) examined video elicitation reflection in the context of teacher training, referring to this as Video Elicited Reflection

(VER). The study concluded the use of video elicitation encouraged reflective commentary. This concept was also examined by Alsu hail (2016) who found it allowed teachers to detail topics related to their role, such as techniques, strategies and daily classroom management in their reflections.

Each of the studies that adopted video elicitation found it to be an effective method. The ability to replay and manipulate the interaction encourages reflective practice. As it has also been shown that virtual reality is a useful tool in construction safety training this creates the following question:

Would a combination of virtual reality and video elicitation be beneficial for health and safety training and if so what is the student's perception of its effectiveness?

2. MATERIAL AND METHODS

This study aims to investigate the combined use of video elicitation and virtual reality within the field of architectural, engineering and construction health and safety training. For this pilot study a group of 11 higher education students were selected based on their commercial roles within industry as quantity surveyors (QS). These were final year students however due to their role they had limited site experience and a varied exposure to VR tools. This study adopted a three-stage process (illustrated in figure 1)

2.1 Stage 1

In the first stage, students were briefed and asked to use a HTC vive pro head set and controllers to navigate a REVIT model in VR. This model comprised of primary structural components with the roof and floor elements intentionally removed to one section of the model. Whilst immersed the students were given the follow an activity:

As a designer of a new commercial build, you are tasked with assessing the risks of installing the roof rafters and floor joists. To complete this exercise you are to explore the proposed build, report on the hazards and discuss your proposed means of controlling these hazards during the construction phase.

The brief allowed the students to independently navigate the virtual environment. They were able to assess the project and plan out the works without any assistance or intervention. They were asked to describe their thoughts including hazards they had identified and potential working solutions. This virtual interaction was recorded on screen (visual only) for analysis in stage 2.

2.2 Stage 2

Having completed the activity and explored the VR model, stage 2 involved the collection of qualitative data through video elicitation interviews. During these interviews the recorded footage was played back whilst the interviewer and student discussed details of the footage (the interviews were recorded in audio only). The interviews were designed to be a combination of structured and non-structured questions. The structured questions were used as the starting point while the video was used as a stimulus to prompt non-structured discussion (Henry & Fetters, 2012). The interviewer and student examined the recorded footage alongside the questions prompting a discussion around the task. This allows the students to be able to reflect on their initial interaction and share their thoughts on the effectiveness of the VR tools.

2.3 Stage 3

Like works of Vieira (2014) the final stage collated the data by transcribing each of the interviews and organised the results into the common themes and trends. These are then presented in the final report findings.

3. RESULTS AND DISCUSSION

Whilst transcribing the video elicitation interviews, various key themes emerged. It identified that their comments either referred to the general experiences of the immersive training or specific moments in the video playback. This paper will focus on the three main key themes identified through the analysis. These were 1) experience and engagement 2) using VR and video elicitation for training 3) recommendations of using VR for safety training.

3.1 Experience and Engagement

Whilst reviewing their recorded footage from the VR interaction, students compared this to conventional training

methods. This included the level of engagement, usability and relevance to their roles. As shown in the comments below, students often spoke of increased visualisation and compared this to traditional classroom based theory sessions.

Student 8 *“Usual health and safety training you are just sat in a classroom so it is better to visualise it and move around the model...especially for someone like me who does not have that much experience on site, it really does help to visualise it and see what it will look like as it is been built”*.

Student 10 *“I think VR is very good for health and safety, you get to see where the risks are and where the potential health and safety hazards are... its very useful, it could be used for training courses or tool box talks. This could show the operatives the risks on site without encountering them, which could reduce the chance of accidents”*.

Student 11 *“I think using VR helps you to visualise the project a lot more. You can see the hazards and you are able to look at different methods that you could utilise...I think it is a lot more engaging than other methods. It is something which probably should be used by more people, mainly due to the visualisation as not everyone sees the same things especially on new projects”*.

In addition to the visualisation many students commented on the usability of the VR equipment. Student 8 commented on the quick adaption to the controls declaring, *“I could use it after around 30 seconds and easily move around the model”*. When asked to express their views on the navigation tools, student 4 explained, *“I think it was pretty easy to use, once you get your hands on and move around, navigating around it was pretty useful. You could put yourself in positions that you are not usually in and look at the works from different angles”*.

In all instances the students described the experience as engaging, often expressing a link to the feeling of 'presence' through realistic visuals (Li et al., 2012) and accurate calibration. Student 2 linked these visuals to their role and that of safety perception commenting *“it makes you have a better idea of the site other than just seeing drawings. As on drawings, especially as a QS I find it hard to appreciate dimensions. You don't appreciate how far things are way and the gaps - you would not think that the gaps were big enough to fall down, they could fall though”*.

One student however pointed out *“you are so immersed in it, the way you perceive it can almost throw you off balance. When you get up high in the model your brain almost tricks you to think you are actually somewhere up high, it can be unnerving”*.

On two separate occasions students highlighted the importance of model detail and the necessity to include external site environments within the training models. For example one student stated *“I think if the model had external factors say around the building this would have been a really key aspect... anything that would have an impact on building or what would potentially stop you from being able to build”*. This aspect again linked to the importance of model realism and the importance of 'presence' (Jeelani et al., 2017).

A number of students also mentioned a 'gimmicky' and 'novelty' aspect of this tool suggesting that the engagement maybe due to the excitement of the technology itself. Lin et al. (2011) considered this and found that using gaming technologies increased students engagement, motivation and results partly due to their interest in using the technology. Although when the interviewer asked *“do you think that if the novelty faded the engagement also would?”* One student paused for a moment and replied *“no... I think the engagement would stay, as it is more interactive rather than sitting and having someone talk all day. You have the navigation and you can move around yourself so it keeps you more engaged”*.

During the interviews many students expressed frustration towards conventional safety training as they found it to be none role-specific. They implied that although suitable to site operatives or site management the link to their role as a QS was overlooked. Students often used this as a point of comparison when reflecting on their immersive experience. A number of students commented on how their discussion of the video footage allowed them to form links between health and safety planning and their commercial roles. For example, during one interview the interviewer paused the footage as the student appeared to be analysing the steel frame configuration (see figure 2). When asked *“what were you thinking at this point”* Student 1 replied *“from a trainee QS point of view we do not have the site experience and therefore is harder to understand when discussing the steel work or health and safety considerations on site, this really allows me to visualise it”*. In another example, both the interviewer and student were discussing footage of the student assessing access equipment needed to install the roof rafters (see figure 3). Having discussed various possibilities, student 2 reflected, stating *“As a QS it has allowed me to appreciate why additional costs are necessary in ensuring health and safety”*.

3.2 Using VR and Video Elicitation for Health and Safety Training

In the initial interaction the students were tasked to consider how they would carry out the installation of the roof rafters and first floor joists. During the video elicitation interviews both the interviewer and student studied the footage together. The interviewer asked the student to discuss their initial ideas. Student 10 stated *“So at the start I wanted to see what the finished elements were, so I could get an idea of what to do first. I think to install the elements there could be a crane on a crane mat which could be adjacent to the building, which could assist to install the roof. Now I look back at this, for the floors I think there is enough space to have a mobile elevating working platform (MEWP) and have 1 or 2 operatives working”*. Through this statement the researcher observed that the use of video playback allowed the student to re-evaluate their method of installation. This was not an isolated case. Throughout the video elicitation interviews' many students reflected and engaged in further discussion during specific moments within the video footage. For example, student 8 said *“when you are looking at it for the first time with the head set you are still getting used to everything, whereas now I can look at it again and go back and forwards, rewind and get a better look. When you are in there you are very immersed and it's hard to look at everything at once... like here I can see that a crane would be ideal”*.

In line with the brief, students discussed their thoughts of suitable safe access equipment to install the roof and floor. Many of the students explained how they used the VR environment to simulate the potential logistical and practical aspects of vehicle movements. For example, whilst reviewing the footage of the first floor access, student 4 pointed out, *“Here I was thinking of the different hazards you could be involved with. I was considering the use of a MEWP. This allows you to put yourself into the positions and think...would I be able to use a MEWP in this situation and how the logistics would work”*.

Through the VR experience and video elicitation each student identified an adequate means of access either via MEWP and/or fixed scaffolding. A number of students commented on the video elicitation method suggesting that analysing the footage allowed them to relive their experience. For example:

Student 9 *“this gives you a chance to take a step back and look again. When you are using it you can get caught up in the movement of the controls, whereas when you watch it you can take yourself out of it”*.

Student 2 *“it takes you back to that point in time and what you were thinking at that actual position...when we look at this I can see what I looked at and what it made me think at the time – I now have the same thought processes again”*.

Students were asked about their views on the combined use of VR and video elicitation as a training method. Student 6 commented *“I think it would be helpful because I can focus on what I am watching rather than what I was doing. I like that I can talk it through using this. This could be a great way to learn”*.

Many of the students commented specifically on the effectiveness of the video playback and how this allowed them to reflect. For example student 5 commented *“to some extent it helps you bring it back, not quite to the same detail, but you can remember how you felt. So for example when I looked down and I saw it on screen I remember how I felt when I was in the VR so that was quite useful”*. In many cases the students compared watching the video footage to their immersive experience. One student suggested, *“the video playback is useful as it clarifies what you did see and you can go back and check although I don't think it would be as good as when the student wears the headset”*, adding *“actually, being in the VR model holds the most benefit”*.

In one case a student added their views on further use of this footage in group work suggesting *“it's nice being in the VR but for a group activity you could first use the VR, play it back and then have the group feedback. Commenting on what they had missed or what they could have looked at. It is nice to get other people's opinions too”*.

3.3 Recommendations of using VR for Safety Training

To conclude the interviews, the students were asked to discuss their recommendation of using VR for safety training and if VR assisted in their understanding. Examples of their responses included:

Student 11 *“Yes for safety management I would recommend it because it is much easier to spot the hazards. You could still use traditional methods as well, but using this might allow you to see something you may have missed before”*.

Student 4 *“Yes I think so because as I said before it gives people the chance to be hands on and see how it could really work, rather than just looking at drawings. It gives you more of a learning experience”.*

Student 9: *“yeah definitely it’s good to have technology like this and being taught it now, because it will eventually become more popular in the industry and you want people to identify risks and hazards earlier in the design process”.*

Although the vast majority of students gave positive feedback from their experience, some students highlighted limitations of using VR for safety training. For example, student 7 commented *“The VR does this in more of a gimmicky way, I can understand it in certain instances. I personally don’t understand the need for the VR itself. I can see it’s new, it’s immersive so you would probably get good engagement but it is not going to be for everyone”.*

4. CONCLUSION

This pilot study aimed to explore the combined use of video elicitation within the context of health and safety training using VR. It allowed the students to review and discuss the video footage in an engaging environment to further their understanding. Specifically it was observed that combining video elicitation and VR in this training exercise aided in effective decision-making, particularly in testing feasibility and the selection of access plant. Although the importance of adding realistic model detail and the surrounding environment to give a feeling of presence was highlighted, in some cases this ‘reality’ caused students to have an *“unnerving”* feeling. The video elicitation interviews provided the time to reflect, review and discuss the footage with the interviewer. This naturally offered the students further opportunities to enhance their learning.

The use of this interview method not only captured their general experiences but also provided learners the opportunity to analyse specific moments which otherwise would have been overlooked or forgotten. This was particularly apparent when the students were considering their options on how to plan the work safely. In some cases this approach gave the students an opportunity to rethink and discuss their initial ideas outside of the immersive environment. Through the combined use of VR and video elicitation the students could first assess and test their ideas. Then by replaying their interaction the students could elaborate, reconsider or justify their decisions particularly around appropriate access equipment. This combined use of methods also assisted many students in finding direct relevance of the training to their role. Students expressed a deeper understanding of the planning process and appreciated the costs associated with carrying out construction activities safely.

Although students identified VR to be the most useful aspect, combined with video playback made this more effective for learning. This study proposes that although video elicitation interviews is an effective method to collect qualitative data, when combined with VR it could in fact provide an effective approach for learning. The practical implications of applying this in the field of safety training could be particularly useful for those in commercial or managerial roles. Using this alongside conventional methods could provide students an engaging risk free practical method of training with the added ability to replay and discuss the interaction.

This pilot study sets the groundwork for future exploration of this combined approach. This study was undertaken using a small number of participants with commercial roles and focused on their individual feedback. There is scope to expand this study using a larger number of individual participants at various levels of experience as well as the potential for testing this approach with whole groups in different disciplines. Further larger studies could prove to be beneficial and should be given further consideration. It is therefore recommended that further research into the combined use of VR and video elicitation be undertaken within the architectural, engineering and construction sector to explore its effectiveness as a teaching and learning technique.

5. FIGURES AND TABLES

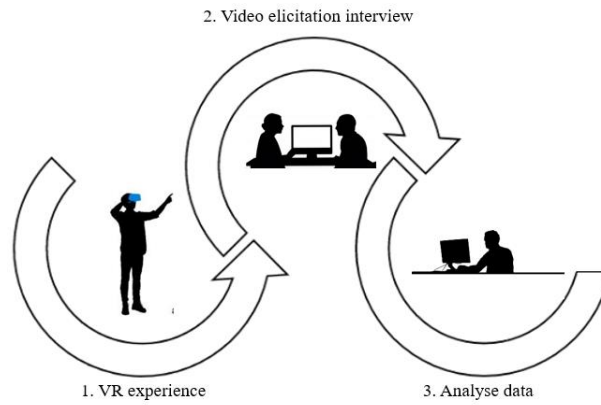


Figure 1 methodology stages

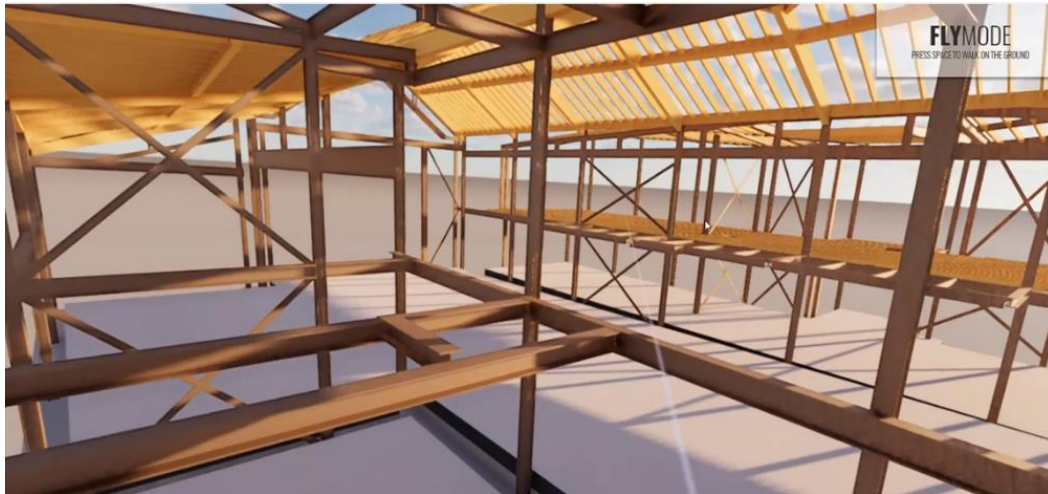


Figure 2 Students interaction with steel configuration

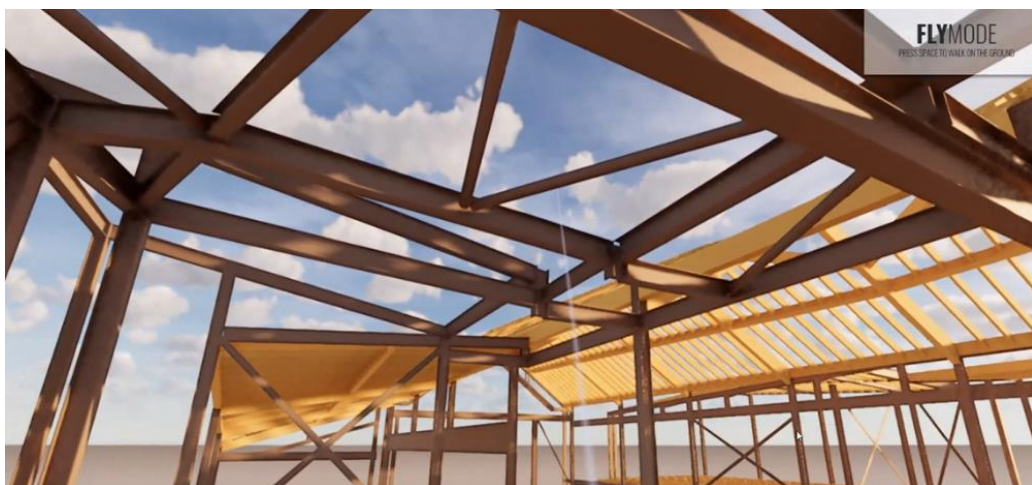


Figure 3 Students planning of roof installation

6. REFERENCES

- Alsuhail, H. (2016). Teachers' third eye: Using video elicitation interviews to facilitate Kuwaiti early childhood preservice teachers' reflections. Retrieved from <http://search.ebscohost.com/login.aspx?direct=true&db=psyh&AN=2017-10859-237&lang=de&site=ehost-live>
- Chevin, D. (2018). Survey: BIM Level 2 uptake still slow, but AR and automation up. *Construction Manager*. Retrieved from <http://www.constructionmanagemagazine.com/insight/bim-level-2-uptake-still-slow-ar-and-automation/>
- Gheisari, M., & Esmaeili, B. (2019). PARS: Using Augmented Panoramas of Reality for Construction Safety Training. Study Number: 17-7-PS. In CPWR. Retrieved from <https://www.cpwr.com/sites/default/files/publications/SS2019-PARS-construction-safety-training.pdf>
- Guo, H., Li, H., Chan, G., & Skitmore, M. (2012). Using game technologies to improve the safety of construction plant operations. *Accident Analysis & Prevention*, 48, 204-213. Retrieved from <https://www.sciencedirect.com/science/article/abs/pii/S0001457511001680>
- Hafsia, M., Monacelli, E., & Martin, H. (2018). Virtual Reality Simulator for Construction workers. *Proceedings of the Virtual Reality Conference – Labal Virtual*. Retrieved from <https://dl.acm.org/citation.cfm?id=3234298>
- Henry, S. G., & Fetters, M. D. (2012). Research Method for Investigating Physician-Patient Interactions. *Annals of Family Medicine*, 10(2), 118–126. <https://doi.org/10.1370/afm.1339>. Department
- Henry, S. G., Forman, J. H., & Fetters, M. D. (2011). “How do you know what Aunt Martha looks like?” A video elicitation study exploring tacit clues in doctor-patient interactions. *Journal of Evaluation in Clinical Practice*, 17(5), 933–939. <https://doi.org/10.1111/j.1365-2753.2010.01628.x>
- Jeelani, I., Han, K., & Albert, A. (2017). Development of Immersive Personalized Training Environment for Construction Workers. *ASCE International Workshop on Computing in Civil Engineering*, 407–415. Retrieved from <https://ascelibrary.org/doi/pdf/10.1061/9780784480830.050>
- Jewitt, C. (2012). National Centre for Research Methods Working Paper: An Introduction to Using Video for Research.
- Le, Q., Pedro, A., & Park, C. (2014). A Social Virtual Reality Based Construction Safety Education System for Experiential Learning. *Journal of Intelligent Robotic Systems*, 79, 487–506. <https://doi.org/10.1007/s10846-014-0112-z>
- Li, H., Chan, G., & Skitmore, M. (2012). Multiuser Virtual Safety Training System for Tower Crane Dismantlement. *Journal of Computing in Civil Engineering*, 26(5), 638–647. [https://doi.org/10.1061/\(asce\)cp.1943-5487.0000170](https://doi.org/10.1061/(asce)cp.1943-5487.0000170)
- Lin, K. Y., Son, J. W., & Rojas, E. M. (2011). A pilot study of a 3D game environment for construction safety education. *Journal of Information Technology in Construction*, 16, 69–83. Retrieved from https://www.researchgate.net/publication/287940483_A_pilot_study_of_a_3D_game_environment_for_construction_safety_education
- Lu, X., & Davis, S. (2018). Priming effects on safety decisions in a virtual construction simulator. *Engineering, Construction and Architectural Management*, 25(2), 273–294. Retrieved from <https://www.emeraldinsight.com/doi/abs/10.1108/ECAM-05-2016-0114>
- Morgan, R. (2015). Combining Video Elicitation Interviews With a Teaching Games for Understanding Coaching Intervention To Improve a Mini Tennis Player'S Tactical Decision Making. Cardiff Metropolitan University.
- Park, C., Le, Q., Pedro, A., Lim, C., Park, H., & Kim, H. (2015). A Framework for Using Mobile Based Virtual Reality and Augmented Reality for Experiential Construction Safety Education. *International Journal of Engineering Education*, October, 31(3), 713–725. Retrieved from https://www.researchgate.net/profile/Chansik_Park3/publication/276025929_A_Framework_for_Using_Mobile_Based_Virtual_Reality_and_Augmented_Reality_for_Experiential_Construction_Safety_Education/links/554e218708ae93634ec70057.pdf

- Pedro, A., Le, Q., & Park, C. (2015). Framework for Integrating Safety into Construction Methods Education through Interactive Virtual Reality. *Journal of Professional Issues in Engineering Education and Practice*, 142(2). Retrieved from <https://ascelibrary.org/doi/pdf/10.1061/%28ASCE%29EI.1943-5541.0000261>
- Perlman, A., Sacks, R., & Barak, R. (2014). Hazard recognition and risk perception in construction. *Safety Science*, 64, 22–31. Retrieved from <https://www.sciencedirect.com/science/article/pii/S0925753513002877>
- Sacks, R., Perlman, A., & Barak, R. (2013). Construction safety training using immersive virtual reality. *Construction Management and Economics*, 31(9), 1005–1017. Retrieved from <https://www.tandfonline.com/doi/full/10.1080/01446193.2013.828844?scroll=top&needAccess=true>
- Sacks, Rafael;, Whyte, J., Swissa, D., Raviv, G., Zhou, W., & Shapira, A. (2015). Safety by design : dialogues between designers and builders using virtual reality. *Construction Management and Economics*, 33(1), 55–72. <https://doi.org/10.1080/01446193.2015.1029504>
- Sewall, M. (2009). Transforming Supervision: Using Video Elicitation to Support Preservice Teacher-Directed Reflective Conversations. *Issues in Teacher Education*, 18(2), 11–30.
- Shi, Y., Jing, D., Ragan, E., Cho, K., & Ma, S. (2018). Social Influence on Construction Safety Behaviours: A Multi-user Virtual Reality Experiment. *Construction Research Congress*, 174–183.
- Vieira, E. R., O'Rourke, H. M., Marck, P. B., & Hunter, K. F. (2014). Using video-elicitation to assess risks and potential falls reduction strategies in long term care. *Disability and Rehabilitation*, 36(10), 855–864. <https://doi.org/10.3109/09638288.2013.821183>

THE APPLICATION OF VIRTUAL REALITY IN CONSTRUCTION EDUCATION: A SOUTH AFRICA CASE STUDY

Nishani Harinarain

University of KwaZulu-Natal, Durban, South Africa

ABSTRACT:

The construction industry has recognized the potential that virtual reality offers professionals on projects from conception to completion. Currently, there is application of this immersive technology in educational facilities worldwide. However, this is not the case in South Africa due to the inequalities of the past apartheid system. This paper focuses on the concept of applying virtual reality technology in tertiary construction education in South Africa by providing an analysis of students' perceptions and enthusiasm for its implementation. The study employed a quantitative, descriptive questionnaire design with simple random sampling. A closed-ended questionnaire was administered to 60 students in the Construction Studies department at a South African university. The results obtained suggested that students see the advantages of virtual reality technology use in their respective modules but still favored the traditional methods of learning over this enhanced technological learning method.

KEYWORDS: *Virtual reality, tertiary institutions, construction education*

1. INTRODUCTION

Virtual reality (VR) reality is an advanced digital project delivery technology that is currently being used in the construction industry to enhance the precision, efficiency and comprehensiveness of a construction project. However, it has not yet been implemented by universities as a technique to provide students within the built environment with an in-depth understanding of how construction processes take place from conception to completion. This study aimed to investigate how it can be infused in construction education in tertiary institutions and the feasibility thereof. The remarkable development of VR in gaming as well as other applications has significantly contributed to the marketplace over the last two decades. This technology has come a long way since its initial beginnings with the developments made in the recent years to VR technology being very encouraging. It is evident that the next few years VR will be crucial for the construction industry.

2. VR in the construction industry

The architecture, engineering and construction industry (AEC) depends on digital modelling, visual communication and simulation so that construction projects may be completed in a manner that is satisfactory to its end user as well as of high quality (Heydarian, Carneiro, Gerber, Becerik-Gerber, Hayes & Wood, 2015). Currently, virtual reality is being adopted in the industry with the aim of improving communication, coordination between project members as well as visualization. Furthermore, they hold the potential of revolutionizing and improving the approaches that are currently used in the design, construction and operations. The AEC industry has thus taken on the use of VR technology in supporting numerous building and construction simulations as well as information visualizations and organization and team work amongst working parties (Heydarian, Carneiro, Gerber, Becerik-Gerber, Hayes & Wood, 2015).

VR technology is aiding in problem solving. Now that 3-dimensional modeling is used in the construction industry, it can show the customer and project team members specifications on and details of how the project should look (Fade, 2018). VR provides architects and builders with the opportunity of working with full-size structures that are modeled in the VR environment instead of using the traditional route of seeing models on computer screens or on physical scale models (Fade, 2018). The ability to review a design in a 3D, immersive and interactive setting can enhance the understanding of the design's intention, increase the constructability of the proposed project, and minimize modifications identified prior to the construction stage. It allows the project team to "walk through" the building whenever they need to and visualize the elements from any perspective (*ibid*). While building information modelling (BIM) showcases the final product, VR can disassemble and reassemble the features and components

of the structure, repeatedly rehearse the construction process, develop a suitable construction sequence, and provide a near replica illusion of what is to be expected when construction is complete (Henriques & Sampaio, 2007).

3. VR as an educative tool

The primary obstacle experienced in tertiary education is the transmission of real knowledge and realistic context scenarios to students in a lecture theatre setting (Horvath, 2014). Virtual field trips, virtual laboratory experiments and projected videos give students an advantageous educational experiences. Horne & Thompson (2008) believed that the ability to see the 3-dimensionality of objects and surrounding environments from its initial stage to the final operation of the product allows one to comprehend and be fully appreciative of the built environment.

3.1 Benefits of using VR/ AR in education

Several research studies have drawn a definitive link between the use of virtual technologies and improvements in a student's educational performance, motivation and concentration (Bacca, Baldiris, Fabregat, Graf, & Kinshuk, 2014; Holley, Hobbs, & Menown, 2016; Martín-Gutiérrez, Efrén., Añorbe-Díaz, & González-Marrero, 2016; Sotiriou & Bogner, 2008). The challenge to participate, construct and influence objects in a virtual surrounding excites students and holds their attention (Yilmaz, 2018).

Virtual reality holds the potential to be an influential resource in educative endeavors by providing opportunities to students to experience, rather than imagine circumstances and situations. Therefore, the virtual world provides a more controlled environment than the actual world (Christou, 2010).

The benefit of VR when compared to conventional methods of learning is that VR can be exploited in instances where teaching via the real thing is dangerous, impossible, inconvenient, cost inefficient or too time-consuming (Horne & Thompson, 2008). Furthermore, a student is provided with the chance to encounter subject matter that would otherwise be challenging if not impossible to convey using conventional methods, thereby proving to be a valuable support mechanism to conventional learning paradigms (Bilyk, 2018). Through the use of VR, features and components that are commonly referred to as “*hidden details*” in traditional tools can be discovered and inspected more closely or through producing transformations that would be impossible in actual reality (Antonietti *et. al.*, 2000).

An area of concern of the modern education structure is the inadequate capacity to define and exemplify complex concepts and clarify them in a more practical manner. The current way of explaining ideas is frequently a ‘*hit and miss affair*’ in which some students understand the concept while some of their fellow colleagues are unable to (Bilyk, 2018). While this does not pose as great a challenge in humanitarian sciences, it becomes critical in biology, physics, chemistry and construction education fields. Using VR/AR educational apps inclusive of interactive audio-visual aspects, the manner in which complicated concepts are explained is less challenging (*ibid*).

Virtual technologies also create opportunities for disabled students to participate and ease their learning experience (Martín-Gutiérrez, *et. al.*, 2016). Freina & Ott (2015) believes VR can make the most impact in the education of disabled and cognitively impaired students. An study undertaken by McMahon, *et. al.* (2016) on autistic students and students with learning disabilities revealed that through the use of marker-based items on paper, the students were successful in describing scientific vocabulary terms.

3.2 Challenges experienced in the implementation of virtual reality in construction education

While VR offers impressive opportunities for students in construction education, there are still several conflicts and obstacles that may be faced in employing the use of these versatile technologies. The way in which virtual technologies can be smoothly blended into the educational process is still an elusive conception (Martín-Gutiérrez *et. al.*, 2016). The most glaringly obvious argument that every institution raises is that high resolution pictures are developed by large virtual reality facilities with advanced visualisation and magnetic tracking aspects. Although this delivers a high-quality visual display system, it is an expensive process to build these display structures (Baratta, *et. al.*, 2003).

One of the leading barriers that prevents tertiary institutions from incorporating VR as a learning tool is purely

practical because it requires a lot of effort from both the inventors and lecturers to produce quality VR material that will encompass the prerequisites of learning programs. In most cases lecturers are unable to operate and conduct immersive experiences by themselves, resulting in experts being outsourced and consulted (Bilyk, 2018). Martín-Gutiérrez, *et. al.* (2016) had also identified this as a problem and stated that institutions and educators are more reserved to the idea of transitioning from traditional learning methods to interactive, immersive innovations that are out of their comfort zone.

Another challenge faced is that while a newer generation of students possess competent technological skills and are more exposed to new technology, it cannot be concluded that all students are automatically capable of using these advanced technologies in an educational environment (Martín-Gutiérrez, *et. al.*, 2016).

3.3 VR in construction education

It is crucial for students in the construction environment to be able to grasp the content being taught to them (Christou, 2010). Messner & Horman, (2003: 146) observed that “*the building construction process is very important but it is difficult to provide this opportunity to the students in an educational setting*”. With 3D, 4D and VR simulations, students are given the opportunity to investigate different ‘what-if’ scenarios and discern unique answers to challenges faced in the construction planning process. Students can also develop their intuitive qualities by interactive experiences with the virtual objects and all related construction signals (*ibid*).

Construction safety is an area of concern on construction projects with many fatalities occurring because workers do not have the proper training on how to effectively protect themselves (Li, 2017). With the use of virtual reality, workers on a construction site can plan, apply and observe the results of various courses of action and mitigate risk factors. Li (2017) believed that by workers perceiving through a simulated environment the dangers and accidents that can be caused by their actions, it would catalyse them into being more careful.

Construction field trips/site visits is a concept that is being considered by higher education institutions. It involves students being invited to actual construction sites to observe in an interactive manner the nature of construction procedures that takes place on site (Eiris Pereira & Gheisari, 2017). However, as advantageous as this method might be, it is not possible to arrange these field trips often enough. The difficulty of finding a convenient and suitable construction site that will allow students to visit and inspect often makes it possible to only conduct such trips once a semester. Furthermore, it rarely happens that a lecturer is able to find a construction project that is completing the same or similar tasks to the content that is being taught at the time (Zhang, *et. al.*, 2017). Time, transportation, resource and cost constraints also present stumbling blocks in arranging appropriate field trips. The safety of students is paramount in all educational institutions and the safety hazards and concerns that students are exposed to on site prevents site visits from being incorporated as a more efficient and regular learning opportunity (Eiris Pereira & Gheisari, 2017).

George (2018) pursued a study to assess the value virtual construction site tours as an alternative to physical site field trips. The researcher aimed to determine if virtual visits assisted in providing an educative environment that contextualised the coursework, engaged the student and provided a perfect substitute to actual site visits. The research concluded that virtual visits was a valuable addition to educational techniques and suggested that it offers an equivalent experience of physically being present on site. This approach also provides a solution to transportation and safety challenges as well as time constraints (Eiris Pereira & Gheisari, 2017). However, this feature is still a new concept in construction education and further studies need to be done to concretely evaluate the characteristics and efficiency of virtual field trips.

3.4 VR in South African educational institutions

It is a critical aspect for students in the engineering and construction disciplines to be able to comprehend the construction processes through visualization (Jaruhar, Messner & Nikolic, 2011). Students do not have the experience or the expertise to be able to make informed decisions and judgements about construction activities. Therefore, envisioning the theory being taught to them would play a key role in enriching their comprehensibility and help students draw a defined link between the theory being taught, real life construction processes, and finally its end products (Jaruhar, *et. al.*, 2011).

Compared to the educational standards and outputs of other countries, South Africa has a much lower ranking. The literacy, science and mathematical abilities of students in primary, secondary and tertiary institutions remain one of the biggest challenges to overcome (Businessstech, 2018). Language and cultural barriers are evident in all educational institutions due to South Africa being a diverse country with eleven official languages (Lockwood,

2004).

However, Lockwood (2004) and Suleman & Gruner (2018) believe that the introduction of VR in all aspects of educating fields can eradicate this obstacle and assist in delivering better outputs in students. By reducing the amount of text-based study materials in schools and increasing innovative, interactive imageries and simulations, students can comprehend content quicker and more easily because the brain is more compatible with visual media than textbook based learning.

Lockwood (2004) emphasized that in order to fully exploit the potential of virtual technologies, work related content must be locally produced so as to account for the diverse languages spoken and understood in South Africa. Elijah Mhlanga, the chief director for communications at the Department of Basic Education, believes that the infusion of VR in South African education will finally “*facilitate the bridging of gaps within our country, and between us and the rest of the world*” (Businesstech, 2018).

4. RESEARCH METHODOLOGY

This was a quantitative study. Simple random sampling was used to administer closed-ended questionnaires to 60 students in the Construction Studies Discipline at the University of KwaZulu-Natal in Durban South Africa. This Bachelor of Science (BSc) (Property Development) degree is a three year undergraduate full-time degree which is followed by a postgraduate Honors degree in either Construction Management or Quantity Surveying (IKZN, 2020). There are 29 registrable modules and minimum of 432 credits that must be completed in order for the degree to be conferred (UKZN, 2018).

The 5-point Likert scale from “strongly disagree” to “strongly agree” was used. Ethical clearance was obtained prior to data collection. The data was analyzed using the SSPS v25 software. Reliability of the study was measured by means of the Cronbach’s alpha coefficient. As a rule of thumb, producing a coefficient alpha of 0.7 and above entails that the study was reliable with a strong relationship found between the variables used for each research question (Maree, 2016).

The relative agreement index was used to determine the student’s acceptance of the implementation of VR, its advantages and disadvantages and its feasibility in teaching methods.

$$RAI = \sum W / AN$$

Where W = the weights given to each factor by the respondents ranging from 1 to 5. ‘1’ being strongly disagree and ‘5’ strongly agree. A = highest weight (5 in this case) and N = total number of respondents that partook in the questionnaires. The higher the RAI, the more important it is to the implementation of VR.

5. DATA ANALYSIS

Forty five percent of the respondents were honors students and 55% were third year students. Fifty three percent of the students were male and 62% of the students have not tried VR before. The Cronbach’s alpha was 0,812 which was considered acceptable according to Maree (2016).

The first objective of this study was to assess the opinions and attitude of the Construction Studies (CS) students towards virtual reality (VR) as indicated in Table 1. The study revealed that the students are excited and open to the concept of applying VR in the CS discipline as an educating instrument which was ranked first (RII = 0.78). The students also felt that VR will help prepare them for industry once they have received their qualifications. They were also excited about the fact that VR in the Construction Studies discipline would improve the work being taught in lectures by allowing them to better visualise the end product (ranked 2nd with an RII of 0,76).

With a low relative importance index of 0.56, the study established that the majority of students did not have a proper understanding of how VR was used in general and in the construction industry in particular and were not confident in their capabilities to use this technology (RII=0,56). This clearly indicates that the students are not fully aware, or have very limited, subjective knowledge of virtual reality.

Table 1. Students' perception of VR

	Strongly Disagree	Disagree	Neutral	Agree	Strongly Agree	Mean	Std. Deviation	RAI	Rank
I think VR should be incorporated as an educational instrument.	0 0%	2 3%	17 28%	26 43%	15 25%	3,82	0,95	0,78	1
I believe that VR learning tools will help prepare me for the working industry.	0 0%	4 5%	16 28%	23 48%	17 18%	3,88	0,90	0,78	1
Using VR tools will allow me to better visualise the end product.	0 0%	3 5%	17 28%	29 48%	11 18%	3,77	0,79	0,76	2
I think VR will help improve my understanding of the work being taught to me in university.	1 2%	2 3%	13 22%	36 60%	8 13%	3,78	0,76	0,76	2
I am excited at the prospect of using VR in my lectures.	1 2%	4 7%	17 28%	27 45%	11 18%	3,72	0,90	0,74	3
I have an understanding of what VR is.	4 7%	5 8%	6 10%	34 57%	11 18%	3,70	1,06	0,74	3
I have an understanding of how VR is used.	3 5%	12 20%	12 20%	26 43%	7 12%	3,37	1,09	0,67	4
I have an understand how VR is used in the construction industry.	6 10%	19 32%	19 32%	14 23%	2 3%	2,78	1,03	0,56	5
I don't feel confident in my capability to use VR.	6 10%	18 30%	21 35%	15 25%	0 0%	2,65	0,97	0,55	6

The second objective of this study was to understand how the students' respond to technological tools versus conventional learning. Table 2 indicates that forty three students considered that virtual site visits would help them better understand construction activities and to complete assignments and tests (RAI=0,78). The students also believed that VR would benefit them in obtaining additional information about the construction environment. Sixty seven percent of the students believed that VR tools could increase their motivation towards studying and learning. They also felt the VR could stimulate the creativity and that the introduction of these technological tools will make for a fun and memorable learning experience. Although ranked 7th, 45% of the students believed that VR would also be advantageous in eliminating language barriers in the lecture room.

Table 2. Students' response rate on technological tools versus conventional learning.

	Strongly Disagree	Disagree	Neutral	Agree	Strongly Agree	Mean	Std. Deviation	RAI	Rank
I think that virtual site visits would help me understand construction activities better and complete assignments and tests.	2 3%	0 0%	15 25%	27 45%	16 27%	3,78	0,88	0,78	1
I believe using VR may benefit me in obtaining additional information about the construction environment.	1 2%	2 3%	18 30%	24 40%	15 25%	3,83	0,91	0,77	2
I think that the introduction of VR will increase my motivation towards studying and learning.	0 0%	4 7%	16 27%	27 45%	13 22%	3,82	0,85	0,76	3
I believe that VR stimulate student creativity.	0 0%	3 5%	15 25%	32 53%	10 17%	3,80	0,78	0,76	3
I think that the introduction of VR will make for a fun and memorable learning experience in the lecture room.	0 0%	7 12%	15 25%	28 47%	10 17%	3,05	0,83	0,63	4
I believe VR will enhance my understanding capabilities of the work being taught to me.	2 3%	3 5%	17 28%	32 53%	6 10%	3,55	0,81	0,72	5
I think that VR will improve the quality of education in my respective course.	0 0%	5 8%	23 38%	23 38%	9 15%	3,57	0,83	0,72	5
I think it is straightforward for me to become capable with using VR.	2 3%	6 10%	17 28%	26 43%	9 15%	3,58	0,96	0,71	6
I think that VR can be advantageous in eliminating language	1 3%	7 10%	25 38%	21 31%	6 9%	3,23	0,81	0,68	7

barriers in the lecture room.	2%	12%	42%	35%	10%
-------------------------------	----	-----	-----	-----	-----

The challenges to VR implementation were also looked at in table 3. Sixty percent of the students believed that the technological tools were unreliable in lecture rooms, agreeing that if the VR equipment malfunctions, it could hinder the lectures being taught and waste valuable time (RAI=0,72) and that it can create a distracting learning environment. Another concern that the students had was the belief that it will create too much of a game like environment and defeat the purpose of a strict learning environment (RAI = 0,65). Forty percent of the students admitted that they find it difficult to adapt quickly to using technological tools and a 25% felt that they will be overwhelmed by it.

Table 3. Challenges of VR implementation

	Strongly Disagree	Disagree	Neutral	Agree	Strongly Agree	Mean	Std. Deviation	RAI	Rank
I think that if the VR equipment malfunctions, it could hinder the lectures being taught and waste valuable time.	0 0%	9 15%	15 25%	27 45%	9 15%	3,62	0,90	0,72	1
I feel that it is possible that implementing VR in education can create a distracting learning environment.	2 3%	9 15%	23 38%	20 33%	6 10%	3,28	0,94	0,66	2
I think it is possible that VR would create too much of a game like environment and defeat the purpose of a strict learning environment.	3 5%	12 20%	20 33%	17 28%	8 13%	3,22	1,06	0,65	3
I feel that frequently using VR equipment can cause discomfort.	1 2%	2 3%	13 22%	36 60%	8 13%	3,30	1,05	0,65	3
I feel learning using conventional learning methods is too time consuming.	2 3%	10 17%	30 50%	14 23%	4 7%	3,05	0,83	0,63	4
I find it difficult to adapt quickly to using technological tools such as WinQS, Excel, MS Project, AutoCAD.	5 8%	21 35%	10 17%	12 20%	12 20%	2,98	1,23	0,62	5
I think using VR devices as lecturing tools will overwhelm me.	3 5%	25 42%	17 28%	12 20%	3 5%	2,78	0,99	0,56	6

The final objective of this study was to determine if it would be feasible for the Construction Studies discipline to implement virtual reality as a visualization tool and transition away from traditional methods. From the results displayed in Table 4 a total of 62% of respondents agreed that an immersive experience would be better than a theoretical lesson (RAI = 0,74) but 59% felt that it would be too expensive to implement in educational facilities. Only 42% of the students felt that a virtual based learning experience would be better than traditional learning methods and only 44% felt that the technological methods of teaching would be better than textbooks. This indicates that students were not altogether convinced that a virtual based learning experience would be better than traditional methods. This could be because the students did not possess the expertise to exploit the potential of VR because only 43% of respondents believe that they had the expertise required to utilise VR.

However, with a low RII of 0.53 for the statement “*I do not like using technological devices and computer software to learn for tests, assignments, etc.*” it was deduced that the students maintain a positive attitude towards using technology to complete tasks in university. Furthermore, it was determined that the students understood that VR is compatible with technological devices that is commonly used, but not owned, by all (58%). This information led the researcher to believe that while students are keen on, and embrace the use of technological methods in tertiary education, the study still shows that traditional methods are preferred over other methods.

Table 4. Feasibility of VR implementation

	Strongly Disagree	Disagree	Neutral	Agree	Strongly Agree	Mean	Std. Deviation	RAI	Rank
I would prefer to have an immersive experience about the construction processes instead of a theoretical lesson.	0 0%	5 8%	18 30%	28 47%	9 15%	3,65	0,86	0,74	1
I feel VR and AR are expensive tools to implement in educational facilities	1 2%	5 8%	19 32%	25 42%	10 17%	3,65	0,94	0,73	2
I have the resources required to use VR such as smartphones, tablets, headsets, desktop, etc.	0 0%	6 10%	19 32%	26 43%	9 15%	3,67	0,88	0,73	2
I believe VR will enhance my understanding capabilities of the work being taught to me.	2 3%	3 5%	17 28%	34 57%	4 7%	3,55	0,81	0,72	3
I believe that technological methods of teaching would be better than textbooks.	3 5%	5 8%	26 43%	19 32%	7 12%	3,35	0,99	0,67	4
I think a virtual based learning experience is better than traditional learning methods.	3 5%	6 10%	26 43%	21 35%	4 7%	3,28	0,92	0,66	5
I feel it is easier to read and learn from textbooks for exams, assignments etc. than using visualisation methods.	3 5%	15 25%	17 28%	18 30%	7 12%	3,13	1,08	0,64	6
I have the expertise required for me to use VR	8 13%	14 23%	18 30%	14 23%	6 10%	2,82	1,10	0,59	7
I do not like using technological devices and computer software to learn for tests, assignments, etc.	11 18%	21 35%	13 22%	7 12%	8 13%	2,48	1,16	0,53	8

6. CONCLUSION AND RECOMMENDATIONS

The purpose of this study was to determine if VR should be implemented in the Construction Studies discipline at the University of KwaZulu-Natal in South Africa by considering how accepting the students were to the implementation of VR, the technological tools versus conventional learning, the challenges in its implementation and the feasibility of its implementation.

The results obtained from the data collected suggested that students are eager to have VR implemented into their learning methods. Additionally, even though students have not used VR in a lecture room before, the students did see some of the benefits of the use of technological tools versus conventional learning. Although the students want to embrace technological methods, the study still indicates that the traditional learning methods is still favored over the technological learning methods because the students did not have a strong understanding of what VR is and the potential it has in education, they are not fully aware of precisely how these innovative technologies are used in the construction industry and they felt that due to equipment malfunctioning, valuable time could be wasted in lectures.

Currently, VR and AR are revolutionizing construction industry and being used from the conception to completion phase of many construction projects. These technologies are changing the way that construction is currently being carried out. The study was undertaken to assist in determining if it should be introduced in universities for educative purposes. With the introduction of VR and AR in education, tertiary institutions offering construction related qualifications could keep up with the current technologies being used in the built environment sector and students could thus be familiar with these technologies when they go into the industry. Additionally, VR and AR could help students visualize the theory being taught to them and this could be achieved by the application of site visits or any other construction building sites. By the introduction of this new technological feature, students could draw a defined relationship between theory and the construction product and help them gain a better understanding of construction processes and procedures.

It is recommended that a further study be conducted with the academic staff and administrators so that their input and suggestions on the possible implementation of VR can also be considered.

7. REFERENCES

- Antonietti, A., Rasi, C., Imperio, E., and Sacco, M. (2000). The Representation of Virtual Reality in Education. *Education and Information Technologies*. 5. 317-327. 10.1023/A:1012057608694.
- Baratta, A., Messner, J., Whisker, V., & Yerrapathruni, S. (2003). Using Virtual Reality to Improve Construction Engineering Education. [ebook] Available at: https://www.researchgate.net/profile/Anthony_Baratta/publication/249864710_Using_Virtual_Reality_to_Improve_Construction_Engineering_Education/links/00b7d53a050f2ee407000000.pdf [Accessed 14 Apr. 2019].
- Bilyk, V. (2018). AR / VR Education: Practical Application of the Technology. [online] Theappsolutions.com. Available at: <https://theappsolutions.com/blog/development/ar-vr-in-education/> [Accessed 15 Apr. 2019].
- Businesstech. (2018). SA provincial governments in talks to pilot virtual reality learning solutions in selected schools. [online] Available at: <https://businesstech.co.za/news/technology/249641/sa-provincial-governments-in-talks-to-pilot-virtual-reality-learning-solutions-in-selected-schools/> [Accessed 16 Jul. 2019].
- Christou, C. (2010). Virtual Reality in Education. Affective, Interactive and Cognitive Methods for E-Learning Design, [online] pp.228-243. Available at: <https://www.researchgate.net/publication/272677840> [Accessed 12 Apr. 2019].
- Eiris Pereira, R. and Gheisari, M. (2017). Site Visit Application in Construction Education: A Descriptive Study of Faculty Members. *International Journal of Construction Education and Research*, 15(2), pp.83-99 [Accessed 06 Jul. 2019].
- Freina, L & Ott, M. (2015). A Literature Review on Immersive Virtual Reality in Education: State of the art and perspectives.
- George, B. (2018). Using Virtual Tours to Facilitate Sustainable Site Visits of Historic Sites. *European Journal of Sustainable Development*, [online] 7(4). Available at: <https://ojs.ecsdev.org/index.php/ejsd/article/viewFile/720/715> [Accessed 15 Jul. 2019].
- Henriques, P. and Sampaio, A. (2007). The Use of Virtual Reality Models in Civil Engineering Training. *International Journal of Simulation Modelling*, [online] 6(2), pp.124-134. [Accessed 14 Apr. 2019].
- Horne, M. and Thompson, E. (2008). The Role of Virtual Reality in Built Environment Education. *Journal for Education in the Built Environment*, [online] 3(1), pp.5-24. Available at: <https://www.tandfonline.com/doi/full/10.11120/jebe.2008.03010005> [Accessed 29 Mar. 2019].
- Horvath, I. (2014). State Of The Art of Using Virtual Reality Technologies in Built Environment Education. [online] Budapest, Hungary. Available at: https://www.academia.edu/16808927/State_Of_The_Art_Of_Using_Virtual_Reality_Technologies_In_Built_Environment_Education [Accessed 29 Mar. 2019].
- Li, R. (2017). Virtual Reality and Construction Safety. *An Economic Analysis on Automated Construction Safety*, pp.117-136.
- Lockwood, D. (2004). Evaluation of Virtual Reality in Africa, An educational perspective. [ebook] Paris: The Naledi3d Factory (Pty) Ltd. Available at: <http://www.unesco.org/new/en/communication-and-information/resources/publications-and-communication-materials/publications/full-list/evaluation-of-virtual-reality-in-africa-an-educational-perspective/> [Accessed 16 Jul. 2019].
- Maree, K. (2016). First steps in research. 2nd ed. Pretoria: van Schaik Publishers.
- Martín-Gutiérrez, J., Efrén, C., Añorbe-Díaz, B. and González-Marrero, A. (2016). Virtual Technologies Trends in Education. *EURASIA Journal of Mathematics, Science and Technology Education*, 13(1).
- McMahon DD, Cihak DF, Wright RE, Bell SM. (2016). Augmented reality for teaching science vocabulary to postsecondary education students with intellectual disabilities and autism. *Journal of Research on Technology in Education* [Accessed 06 Jul. 2019].
- Yilmaz, R. (2018). Augmented Reality Trends in Education between 2016 and 2017 Years. [online] Available at:

https://www.researchgate.net/publication/325339557_Augmented_Reality_Trends_in_Education_between_2016_and_2017_Years [Accessed 3 Jul. 2019].

Zhang, C., Lu, Y., Xu, R., Ye, X., Shi, Y. and Lu, P. (2017). An Educational Tool based on Virtual Construction Site Visit Game. *Modern Applied Science*, 11(8), p.47.

USING VIRTUAL REALITY TO EVALUATE THE IMPACT OF DISPERSION OF ELEMENTS ON KINETIC FACADE

Mojgan Rezakhani

Department of Convergence Engineering for Future City
Sungkyunkwan University, Republic of Korea

*Sung-Ah Kim**

Department of Architecture
Sungkyunkwan University, Republic of Korea

ABSTRACT: *This Study investigates an aspect of kinetic façade based on patterns for meeting arrangement components in case of motion and structure pressure. Most kinetic façades include a pattern that shows how supporters, grids, and nodes connecting to each other for carrying façade on building. Regard to geometric patterns, it is considered Persian patterns due to produce integration aesthetic design, also the proportion of triangle and hexagonal ride as a base. Previous studies have rarely emphasized designing joints and components for the moving systems. It is necessary for the designer to have knowledge about that. Virtual Reality and simulation software could be so helpful to predict the motion of components regard to stability. The use of Virtual Reality provides information through Vive Headset devices to analyze Kinetic Façade. The main focus of the experiments was to predict and calculate the position of pivot point in geometry patterns. The application employs data obtained from karamba3D. The results reveal which design of pattern can access better arrangements for kinetic facade and add an important factor for designers to pay more attention. This finding not only offers the instruction for optimization of designing Kinetic façade that causes architects to better understand moving mechanism.*

KEYWORDS: *Kinetic Façade, Virtual Reality, Geometry Pattern, Elements.*

1. INTRODUCTION

It is clear that the role of the façade to increase and decrease internal comfort and energy consumption respectively. Also, outside architecture's domain of buildings is the suitable base place for the design of motion components however There is a lack of content and the traditions of the static form (Moloney, 2011). During past decades, different kinds of algorithms and supplemental control devices were proposed due to make a better performance (Amini *et al.*, 2018). The following reformation from static to movement, the thought of architecture has been changed deeply (Elkhayat, 2014). Kinetic façade is an active architecture that is responsive to environmental conditions. In order to satisfy user based on changing needs, these systems are usually made of two parts: a solid structure sequesters and a movable textile infrastructure.

Movable panels are the light-emitting curtains that create spatial divisions and personal micro-climates. Kinetic louvers also move in three dimensions to screen sunlight from any angle (1). The kinetic concept was affected by multidisciplinary factors that provide an opportunity to explore a wide domain of parameters across different fields (2). Kinetic form According to Alan Dorin who is theorist, the outcome of a kinetic process are 5 actions: pulse, stream, increase, decrease, complex that provides a range of periodic structures which when combined with a planar variable, have the capacity for a wide range of designs (El-Zanfaly, 2011). The quality of architecture can only result from a coherency between the façade, structure, integral organization, and building services design elements that interact directly with each other (Christian, 2015). The study addresses the research question: What Kind of Pattern would be useful for moving elements in Kinetic facades? How can Architect predict motion behavior in the Kinetic façade? How can make some frameworks for components and elements to design a moving structure? Which pattern for jointing bars and all details would provide the necessary strength? Can we design the best arrangement for pivot points for moving components?

2. RELATED WORK

2.1 Kinetic Facade

the external climatic conditions cause such active façades to respond to the variations through automatic control devices, with the aim of significantly optimizing the energetic performance of the building. Design flexible and reconfigurable are two features of building envelopes that able to dynamically react on the base of the evolution of weather and environmental conditions(Babilio, Miranda and Fraternali, 2019). Database for kinetic Architecture can be known “kinetic architecture matrix” which demonstrates classification methods by the implementation of them. New Matrixes against traditional database are sorted different categories, interests or viewpoints, as well as visualizing interdependencies according to these categories. One of the main features for categorizing Kinetic Architecture is the degrees of freedom of a structure that are the number of independent parameters required to completely specify the configuration of the mechanism(Knight, 2000).

George Stiny and James Gips introduced Shape Grammars in 1972 as a new visual approach to design and analysis(Stiny and Gips, 1971). The one algorithm systems to create design shapes directly instead of indirectly through computations with text or symbols by computation is "Shape Grammars"(Knight, 2000). there are 2 steps for computations on shapes; first recognizing a particular shape, and second applying a rule that specifies which shape could be replaced, and how it could be replaced. Features would be considered in designing Kinetic structure: (1) motion types, whether it is continuous or discrete, (2) the motion speed, (3) the degrees of freedom, (4) the structure scalability. The Matrix method, to categorize and summarized Kinetic design projects, led to an understanding mechanism of movement that would change more approachable for architects and designers. Mechanical analysis of the kinetic mechanism was divided into 3 parts: a) degree of freedom (DOF) type, DOF relates to the joints, and the kinematic connection between the mechanism links. b) number of degrees of freedom (DOF): one DOF, two DOF, or multiple DOF systems for linked (chained) elements mechanism. c) Mechanism implementation: a discrete mechanism for a single operation, or repetitive mechanism for systems that contain a pattern of basic elements creating a dynamic surface or group effect(Ron, Weissenböck and Harari, 2013).

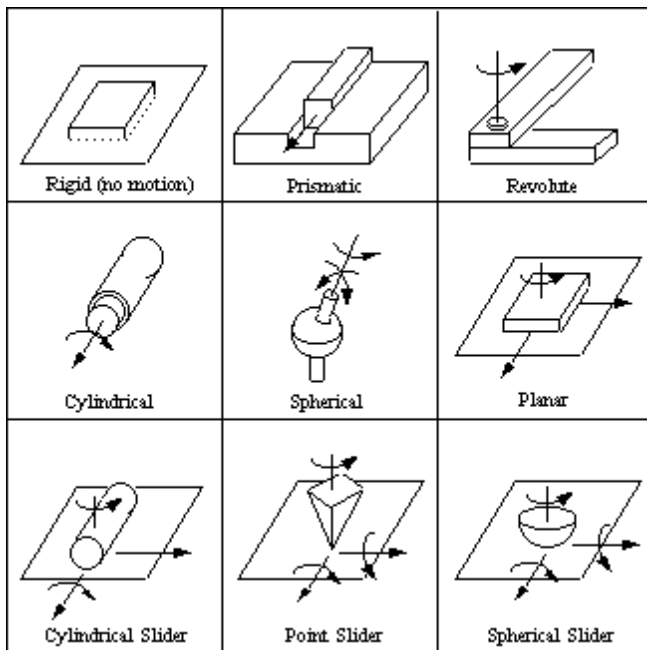


Fig. 1: 3-D kinematic joints and their degrees of freedom(Chase et al., 1995)

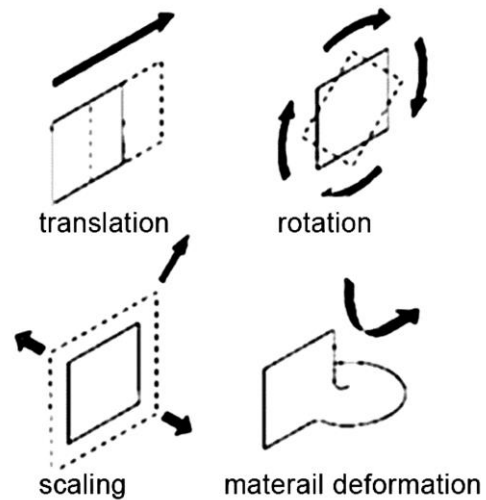


Fig. 2: 3-D kinematic joints and their degrees of freedom(Moloney, 2011)

Movement of objects can be included in Circular Motion, Periodic Motion, Vibration Motion, and Oscillatory Motion. There are three degrees of freedom, depending on how the position or orientation of an object changes with respect to one, two, or three coordinate axes that one can identify for each of these kinds of movement- translation and rotation. An object can get movement by six degrees of freedom around itself. Moving things are triggered by specific forms. Although the explanation of form due to statics objects is more complex than changing forms with movement. It is clear that the kind of elements would be affected by the appearance in the repetition of the movable building elements process. According to the external appearance, one can differentiate between two different design strategies: A single kinetic element follows the movements of neighboring elements independently that would become a swarm-like quality. It should be noted that for different aspects of the Kinetic façade design, there is no certain classification. One classified kinetic architectural structure to motion types of building employed by Michael Schumacher is (1) Swivel, (2) Rotate, (3) Flap, (4) Slide, (5) Fold, (6) Expand, (7) Gather and roll up and (8) pneumatic(Schumacher, Schaeffer and Vogt, 2012).

A. Movable Component

According to Movable components, there are some subdivided that include Movable structure, Movable connections, Actuators, Materials, and Control systems due to the subject of this study, only 2 parts would be explained(Elkhatay, 2014). Every moveable unit should be able to control motion that includes sliders, gears, pneumatics, actuators, hinges, and linkages. As a whole, there are three basic types of motion are rotation, translation, and both rotation and translation together. Also, there are three kinds of transformation for different aims: 1. to the arrangement of the components related to Active Shape, 2. to motion between the components of the Active Shape, such as actuators, hinges, and linkages, 3. to create the geometry of the components of the Active Shape and any other applicable transformations such as a transformation in the materiality of the components of Active Shape(El-Zanfaly, 2011).

The research of transformation mechanisms between stiff components and flexible components shows other kinds of adaption, which cause structural deformation because of changing the functional transformation of stiff components the load path and form at the same time. Stiff components bear loads (both compression and tension) without obvious deformation, while flexible components deform largely and transfer loads to stiff components, such as human joints. Materials in this kind of component play an important role in analyzing each component and their cooperative performances on various load combinations. Ultimate bearing capacity (strength, stiffness, and stability) and serviceability limit state (deflection and crack) would specify the designs of components and structures. In this kind of structure, the stiff and flexible components can convert to each other's, which is also the main concept of the design. Controlling the distinct states of geometries and loads is one keynote for this transformable structure(Wang and Teuffel, 2017).

B. Movable connections

In order to make moveable connections between two load-bearing elements, independent components, bearings or hinges are essential. There are one differentiates between hinged connections in rotation or translation movement in addition to a combination of both movements which can provide five degrees of freedom. Depending on the construction of the hinge, the maximum degree of movement can be artificially restricted through the use of constraints(Schumacher, Schaeffer and Vogt, 2012).

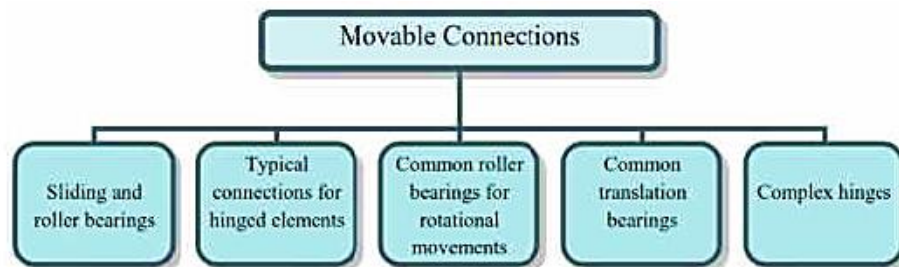


Fig. 3: movable connection types(Elkhatay, 2014)

C. Control systems

To controlling equipment or a machine, Control systems are used in industrial production. One control system is a device, or set of devices, that manages, commands, directs or regulates the behavior of other devices or systems (Sherbini and Krawczyk, 2004). Control system consists of two elements: (1). Inputs give different information about the surrounding environment by sensors and input different methods. There are five modes; Manual Input, Sensors & Detectors, Prior Internal Information, Manual Programming and Internet. (2). Controllers play an important role in moving the structure because of decision to move and therefore they could receive information from input systems and buffer to actuators. There are three modes of Control Systems of dynamic elements, these are as follows: Internal Control, External Control, Complex System (Sherbini and Krawczyk, 2004).

D. Supporter

One of the challenges between structural engineers and architects has always been to analyze and calculate the form designed as a framework. However, if this form was also free-spirited, the interaction between structure and architecture would be associated with certain complexities. Taking advantage of recent advances in design tools, the ability to parameterize the factors affecting the design to provide a variety of design concepts in the design direction has been provided, although the basis of geometric structures remains the same (Shea, Aish and Gourtovaia, 2005). How to control the three-dimensional function of the structure in the X, Y, Z axes for the forces as well as the aesthetic performance of the design along with the reliability of its formal structure in an integrated unit. By thinking about the common elements that define the effective functions of structure and architecture, it can be seen that the use of geometric order in the main structure of the constructor, as a process requiring organic union between structure and architecture, is fundamental. It seems that by recognizing these parameters, in order to maintain the relationship between structure and architecture, one can always expect integrated behavior against the disruptive factors of the structural system of the complex (Fard, 2015).

The existing structures are affected by the shapes of the triangulation mold and truss system at the surfaces. The lack of flexibility in the basic form and also the uniformity of the visual impact of this type of structure, especially in the case of spatial structures, is introduced as the weakness of such structural systems. Therefore, based on the identity of Iranian nodes in terms of aesthetics and sense of space, the structures derived from the main geometry of the node, in addition to providing visual flexibility and avoiding uniformity of dimensions in the wide dimensions of the structure, by creating flexibility in both x and Y dimensions, control Provides route load and incoming force. One approach in recent years has been to examine the behavior of structures using optimization operations. The main purpose of optimizing the structure of structures is to find a suitable geometric structure for the integrated behavior of the structure while maintaining a clear relationship related to its reliability in order to interact with the characteristics of the behavioral architecture (Hassani, Tavakkoli and Moghadam, 2011).

The use of geometry in the alignment between form, stability and proportions has been established as the main current in the interaction of traditional Iranian structure and architecture. Understanding the geometric behavior of components in the process of creating an organic union between physical, spatial and contextual systems will lead to the formation of integrated feedback on the factors influencing the reliability of the set. Iranian nodes, based on the geometric constraints in their structure and proportions, as modular units, have the ability to develop and expand on the X and Y axes, while maintaining the alignment between visual values and functional efficiency. Considering the process of orderliness of the structure of Iranian nodes in the mentioned axes, the transfer of this order in the Z axis to maintain the three-dimensional function of the complex structure can be discussed. In this regard, the process of optimal placement of the supports by maintaining the three-dimensional function between the components in the path to achieve efficient geometry of the node form. Accordingly, after simultaneous analysis of the structure and subsequent structure by the Karamba plugin, the population above the set of genes introduced was selected and the most optimal state of reliability of the supports, except that the structural components have minimal stress. This feedback alignment between architecture and structure in the optimal location of supports, which is achieved with the help of genetic algorithm method, will reduce stress in structural components and also maximize the reliability of the structure along with economic efficiency in the materials used, along with maintaining architectural values.

Based on the specific process derived from the intended behavior, the supports are equipped to prevent deviation and disruption of the behavior of the structural components (Wang, 2004). Examining the proper location of the supports in reducing the deformation of the structure is important for designing structures that bear their own weight (Jang, Shim and Kim, 2009). Therefore, the behavior of the supports against the loads as well as their placement is a very

important point that can be discussed in various aspects such as the reliability of the structure against the loads and also maintaining the integrity of the structure's performance. In examining the location of structural elements such as pressurized members, tensile members or supports, it should be noted that each can play a key role in the structural design system depending on the relationship with other sectors. Therefore, the location of each of these elements in this system makes one of the effective parameters in writing footnotes(Won and Park, 1998).

2.2 Pattern

Form and geometry, in order to create their structural behavior, can conform to the needs of space definition in identity architecture(O'Reilly and Hemberg, 2007). The design of kinetic façades is a parametric process in action or variable space where the designer animates a kinetic assembly to generate a range of outcomes. Geometry is the main focused of Kinetic façade and Parametric design in architecture(Moloney, 2011). Three geometric useful characteristics: First, on different surfaces, these patterns can be fitted such as propagation, curtailment and scaling. Second, self-similar configurations are the most feature that are roughly similar to one part of themselves. This characteristic assists in making use of the properties of fractal geometry in parametric design of the patterns and further modification of an arrangement and density of a typical configuration. Third, although some patterns have differentiae's , they would using the same geometrical processing techniques(Emami, Khodadadi and Buelow, 2014).

2.2.1 Persian Pattern

Persian art is related to era Islamic it was used geometric due to religious sentences. It causes to result geometric exploration, complex and elegant collection of periodic patterns in art and architecture of Persia. The most shape are triangles, rectangles, hexagons, and circles that design for everything. *The first category* single-shaped tiles are just single tile that explode figures by placing in different side of hexagonal (Figure 4). *The second category tiles rotated 45 degree with overlapping such as an eight-pointed star shape*. “If we refer to this shape as S1, an array of S1 is shown in the right diagram of the top row. By joining the vertices in S1, an octagonal tile S2 is obtained” (Figure 5). *The third category* indicates some geometrical construction is added to familiar shapes. The base shape is eight squares. “This gives rise to octagonal holes, which can be filled in by extending the sides of the squares from vertices of the octagon” (Figure 6)(Emami, Khodadadi and Buelow, 2014).

The last category refers to patterns based on concealed grids which require considerable geometrical ingenuity. In this case, a grid of some sort is drawn and then polygons/circles are placed in some regular fashion. Then the circumferences of figures are also divided, marked with points and joined together. After the pattern emerges, the construction lines are removed. The lines in the pattern are often replaced with interlacing lines (Figure 7)(Abas and Salman, 1992). Today, there are a great number of facades and envelopes' technologies that are readily available in the market. The decision as to how they are designed, operated, maintained, and assessed remains a challenge(Attia, 2018).

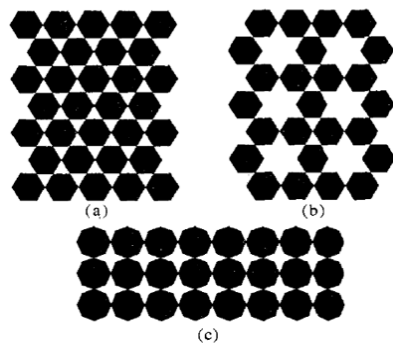


Fig. 4: First category of patterns bases on single shaped tiles(Abas and Salman, 1992).

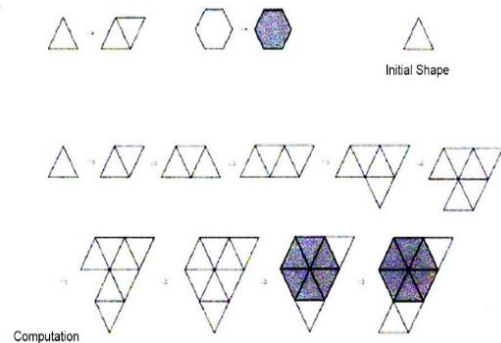


Fig. 8: Rules for a triangle as an initial shape and its computation(Abas and Salman, 1992).

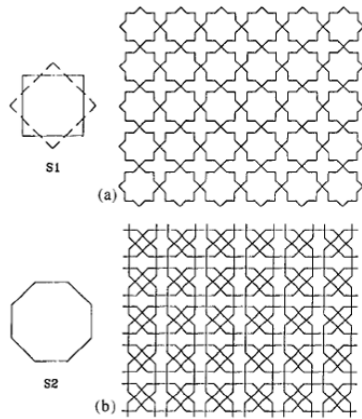


Fig. 5: Second Category of patterns with overlapping tiles(Abas and Salman, 1992)

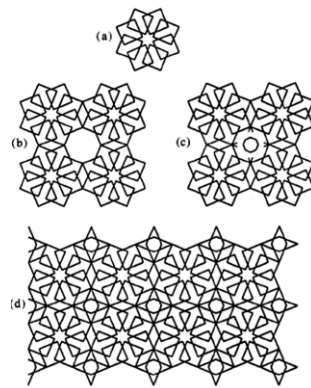


Fig. 6: Third Category of patterns based on geometric construction (Abas and Salman, 1992)

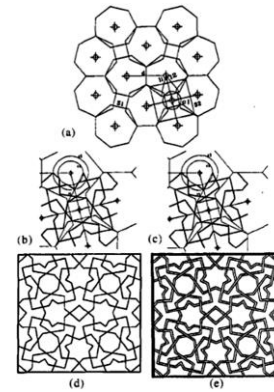


Fig. 7: Fourth Category of patterns based on concealed grids(Abas and Salman, 1992)

2.3 VIRTUAL REALITY

There are two main types for VR that called immersive and non-immersive VR systems they are related to the degree of immersion and interface in a synthetic environment. Immersive VR is an application in terms of quasi-physical experience. In such an experience, a fuller contact occurs between the user and the virtual environment. data gloves and multimedia head mounted display (HMD) are used in this kind of VR. In case of Non-immersive VR, a screen interface and eyeglasses would be practical(Jamei *et al.*, 2017). Unity and Unreal are two Game engines, that represent real physical interaction with light by creating realistic visual effects. Virtual reality as a method present in HMD set up to simulate our environment to recognize better. Our device for doing research was an HTC Vive HMD with an integrated 120Hz binocular. Virtual reality has many potentials to provide and make accessible data easily although it should be applied in many construct subjects, there is still uncertainty with regard to Virtual Reality, few studies have been published on structure issues with using virtual Reality.

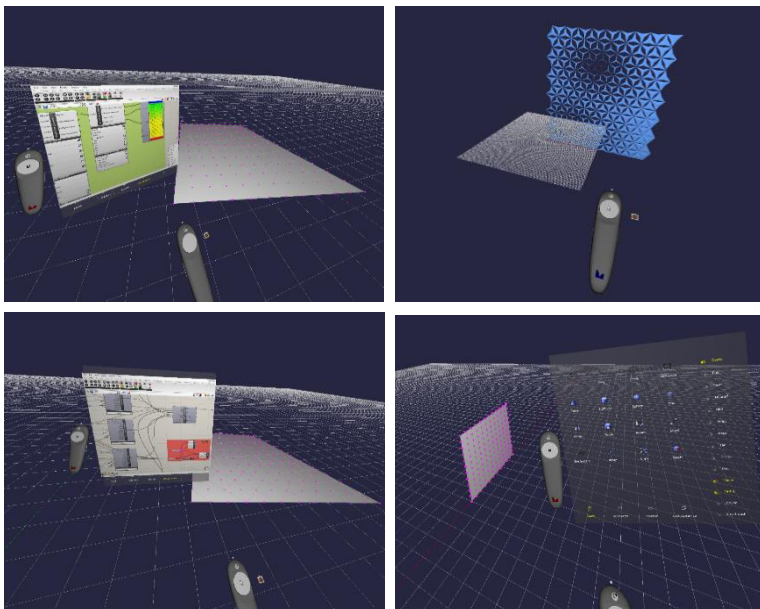


Fig. 9: Grasshopper and Rhino on virtual reality, Headset and controller VIVE (Authors)

3. METHOD

In order to identify the geometry of Kinetic Façade, it is necessary to recognize connections of component and kind of movement in your project also evaluate the possible geometry patterns at the same time. Since the subject of the article is the study of the placement of supports and connections. The grid and arrangement of elements is very important because one of the features of Persian geometric patterns is having hexagons and triangles at the base of geometric patterns. We made it the basis of the work. 6-by-6 square grid with 9 supports located at the intersection of the lines and 8 designs and modes for the lines were considered: diagonal lines from left to right and from right to left, vertical and horizontal lines together and in the form of Separately

In the first case, we considered the supports to be fixed and examined the connection lines in different designs and modes to see how many lines the lines pass through the support. In the first case, we considered the supports to be fixed and examined the connection lines in different designs and modes to see how many lines pass through the support. In the second case, we changed the number of supports. The angle and the number of connection lines change according to the placement of the support. According to Karamba analysis and axial stress images, which are shown in color tones from red to blue, the green and yellow colors indicate more tension next to the supports because they withstand more pressure.

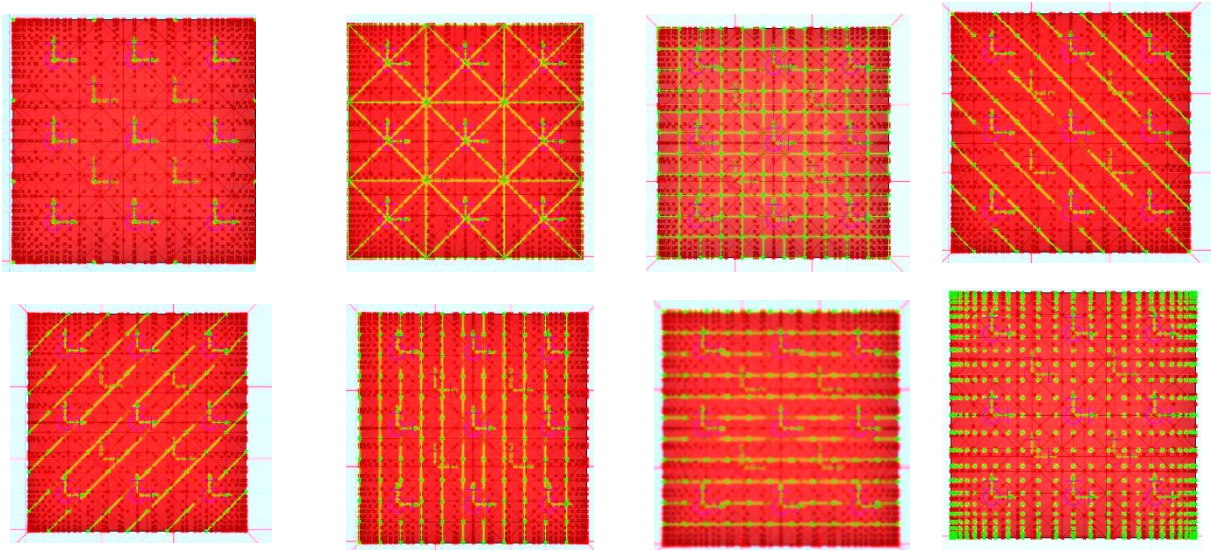


Fig. 10: First Case, supports to be fixed and the connection lines in different designs. Different Position according line of grid with supporters (Authors).

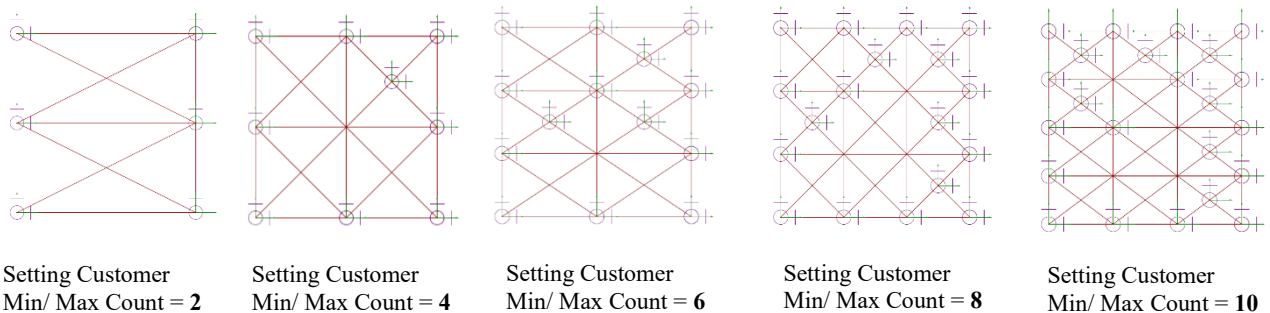


Fig. 11: Second case, to change the number of supports. and the amount of connection lines (Authors).

One of the main ideas in the design of all structures is the stability of the structure and its compliance with the architectural form. The connection between body and function can be provided through geometry and materials (Abdelsalam, 2012). The use of beauty along with creating sustainability by using current technology and available materials has been considered as an approach in this research. In this process, how stress is distributed will be important. Also, with the correct definition of supports, the stress distribution can be determined in specific zoning. Therefore, for this purpose, from the GrassHopper design plugin, the formation of the form with the Karamba plugin was examined. To design the geometric patterns, Rhinoceros software has opted as the modeling platform and Grasshopper, which is a parametric modeling plugin for Rhino, has been used. Grasshopper provides the opportunity to parametrically design and then alter the variables, in order to create various iterations of the design downstream (Emami, Khodadadi and Buelow, 2014).

The parametric world has become so widespread that the fields of parametric architecture are considered as modern specialties in prestigious schools of architecture. While the basic topics in these disciplines, which is the knowledge of the geometry of stability, can be seen in the architecture of civilizations such as Iran. In the past, the Persian architects always dealt with the proportions between the parameters and knew them well so that they could measure the parameter and then fit it with unerring accuracy without any technology that we use today like Parakeet plugin. *Parakeet* is a collection of components focusing on the Algorithmic Pattern Generation; it offers a unique and easy-to-use approach that Generates Geometrical and Natural Patterns/Networks. Parakeet is a Free Plugin upon Grasshopper3d that is Developed by Esmail Mottaghi. We just used Parakeet for designing Persian geometry to find the conceptual to developed on base Persian geometry and structure performance.

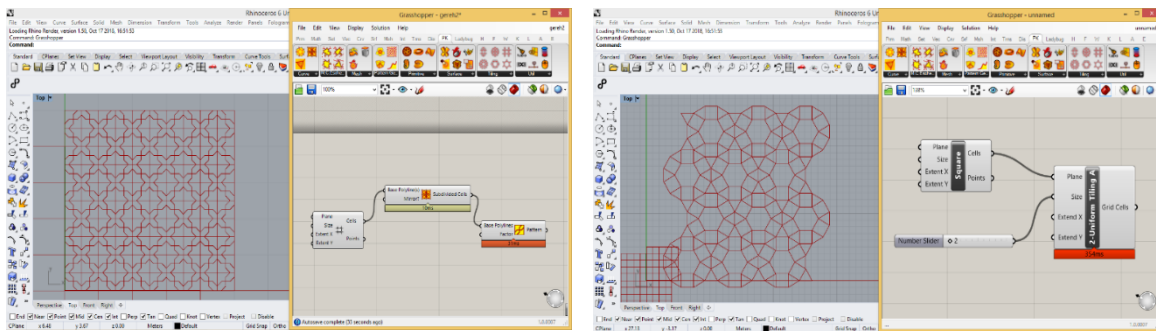


Fig. 12: Two kinds of famous pattern in Parakeet (Authors).

The Karamba plugin establishes the relationship between the parametric model and the behavioral simulation of the structure by applying identifying codes. Using this tool, the stability behavior and turbulence behavior of the structure can be investigated in exchange for changing the parameters applied to the model geometry. In order to communicate between the parametric model and the structural calculation plugin, it is necessary to define detailed information about the location of supports, elements and how to transfer vector or surface load, place of load application, type of load from single or wide, as well as data such as sections of load-bearing elements.

The geometric form of the facade was selected based on the amount of stress caused by this change in the shape of the abutments as well as the amount of "mesh" displacement forming it and was paid in the next steps. Structural optimization can also be performed under finite element calculations. In this way, it is formed by referring to the division of surfaces in mesh formats. Mesh and divisions need to be leveled on each part to implement towards construction. The stress distribution in the middle members, in addition to the material paths to the pressurized structure, is in the direction of confrontation with the opposing forces in each designed module. What result is achieved from the design of an architectural structure is the direction of forces towards each of the modules. If this load distribution can be controlled by the pre-drawn elements. The behavior of the members can be considered complementary. Each module will react to the pressures from different directions to neutralize the forces. Therefore, using both Rhino and Grasshopper in VR, Mindesk is the first real-time platform that provides us for immersive reviews or within Unreal Studio for top-quality real-time renders. In order to analyze, the size of module is 6*6 m2. According to the geometry of the module, different points were considered for the placement of the supports, and various samples of the applied forces of color analysis were taken through Karamba.

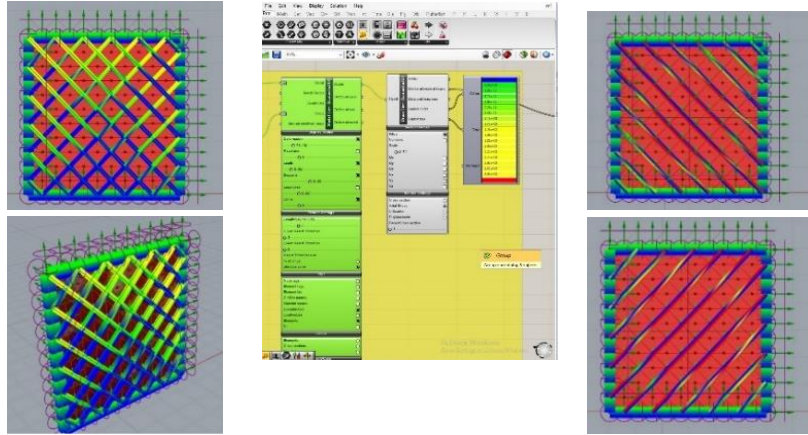


Fig. 13: the results of Karamba (Authors).

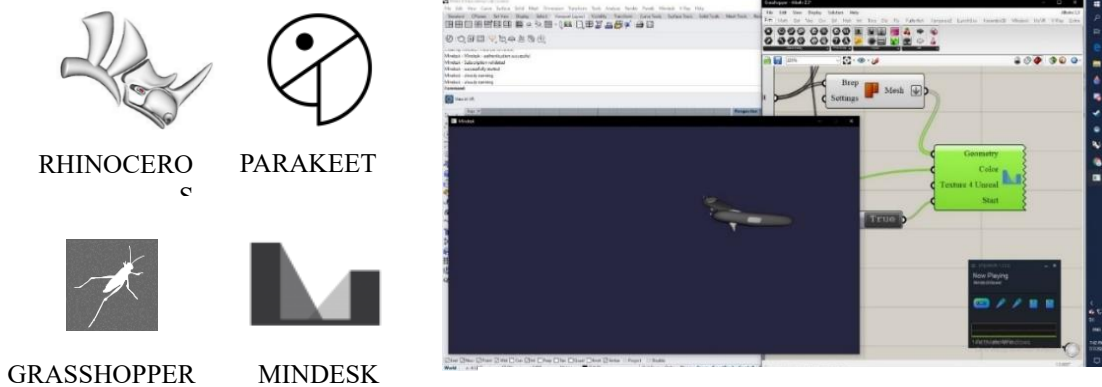


Fig. 14: Rhino and Grasshopper in VR(Authors)

3.1 Case study (Al Bahar Tower)

Since triangle and hexagonal are the base shapes in Persian geometry and this study investigate on kinetic façade, so among real projects, Al Bahar tower was selected to evaluated. The analyzed module is composed of six “micro-triangles,” and is such that its boundary forms a “macro-triangle” when projected onto a plane parallel of the building façade (umbrella-like module). The activation mechanism of the Tensegrity Al Bahar Screen (TABS) module is driven by a linear actuator, which stretches the perimeter strings, by pushing against a vertex of the macro-triangle along its bisector, in parallel to the building façade. The mechanism is guided by two linear springs controlling the in-plane displacements of the other two vertices of the macro-triangle, and a telescopic collar guiding the out-of-plane displacement of the center of mass of the module. The module is described as a tensegrity system formed by 3 strings parallel to the building façade and aligned with the edges of the macro triangle (red-colored members), and 12 bars forming the edges of the micro-triangles (black-colored members). The TABS model is formed by seven nodes (numbered from 0 to 6)(Babilio, Miranda and Fraternali, 2019).

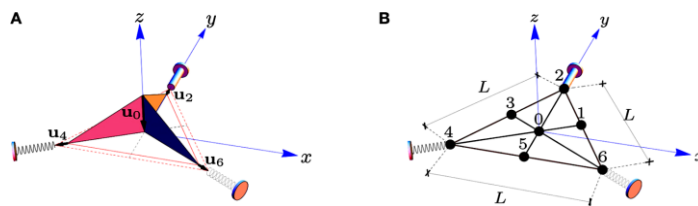


Fig. 15: | Reference (A) and deformed (B) configurations of a tensegrity model of the TABS module. (A) shows the folded configuration of the structure corresponding to the fully opened screen. (B) depicts the flat configuration (fully closed screen), where the module reduces to an equilateral triangle with side L . Nodes

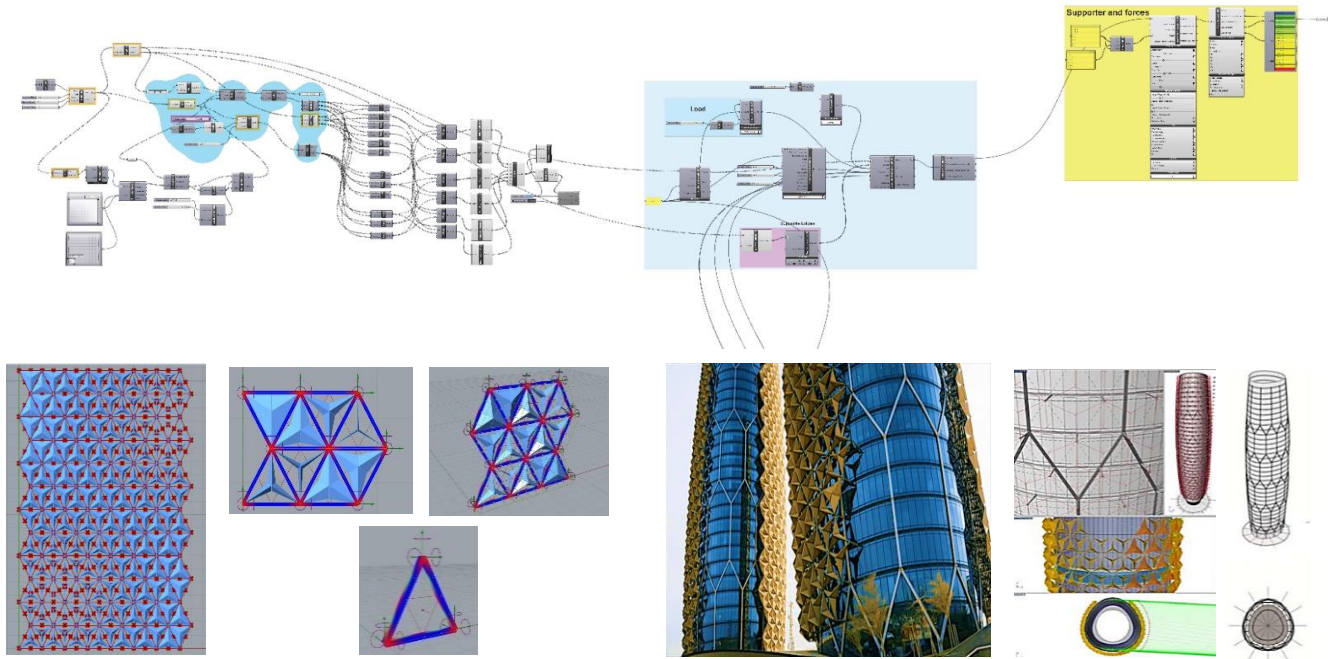


Fig. 16: Geometry of Al Bahar Tower (Authors).

4. DISCUSSION

4.1 Implication

In this paper, we introduced a new aspect and approach of designing Kinetic facades to architects. It is included to encourage architects to know more about the actual movement mechanism such as the position of supporters on grid and links and joints of the elements and components. Geometry pattern specially triangle and hexagonal play important roles to design kinetic facades exactly in some existing real projects. One of the geometric patterns is Persian pattern that is based on triangle and hexagonal. Regarding the research questions, how can make some frameworks for components and elements to design a moving structure? Virtual Reality would be very useful in this process that develops basic information in the first step of designing this structure. Also, these new technologies have many efficiencies to integrate different subjects to evaluate them.

4.2 Limitation and future work

As far as we know, no previous research has investigated VR in structural issues for kinetic facades, according to limitation We aware there were no plugins to connect VR with HMD for analyzing structure directly. Future research should further develop and confirm these initial findings. Firstly, by analyzing and evaluating other geometry shapes with different arrangements. Secondly, making plugins for calculating structural issues that work directly with VR. It may be led to open other aspects of Kinetic systems for us. Finally, we just analyze inner tensions without wind load or other environmental factors that impact on facades.

5. CONCLUSION

The present study aimed to investigate the impact of geometry parameters on Kinetic façade with applying Virtual Reality that is the state art of technology for simulation. The procedure used is as explained in two different aspects of VR, in case of immersive VR So that we could be able to do with these applications (Karamba, Parakeet, Mindesk) and regard to non-immersive VR, we used HTC Vive HMD. The procedure used is as explained in two sections, first the number of supporters is fixed on the grid with different positions of connections, second various number of supporters with different lengths of the connector. The result of analyzing with Karamba showed us supporters make tension in the grid and the width of connectors near supporters could affect the amount of this tension. If architects

consider the analyzing and other factors, Triangle grid could work and make balance in different designing. We investigate geometry of Al bahar tower which is famous kinetic project due to implication Hexagonal and triangle geometry.

We found, if Architects know more about details of kinetic structure and mechanism of movement it is more likely no need to design for moving large part of buildings that cause high cost and complexity in implementation. We can achieve to dynamic and kinetic façade with functional and logical reasons through considering to creative arrangement of joints and components. The present paper aims to reveal underlying technology of the movement structure and improve it. We believe Within the framework of these criteria such as extended knowledge about details of kinetic system; it would be progress and would be more practical and useful. We investigate geometry of Al bahar tower which is famous kinetic project due to implication Hexagonal and triangle geometry. it can be concluded that if the next steps are directed to gathering data with considering some criteria before designing Kinetic façade to create efficient structure, these points are: a) Relationships between supporter and compressive members. b) Behavior of each module in controlling the pressure from symmetrical directions along axis. C) Writing a dynamic algorithm to check for any possible changes.

6. ACKNOWLEDGMENT

This research was supported by Basic Science Research Program through the National Research Foundation of Korea (NRF) funded by the Ministry of Education (NRF-2016R1D1A1B01013694).

7. REFERENCES

- Abas, S. J. and Salman, A. (1992) 'Geometric and group-theoretic methods for computer graphic studies of Islamic symmetric patterns', in *Computer Graphics Forum*. Wiley Online Library, pp. 43–53.
- Abdelsalam, M. M. (2012) 'The Use of Smart Geometry in Islamic Patterns-Case Study: Mamluk Mosques'. CUMINCAD.
- Amini, F. *et al.* (2018) 'Impacts of soil-structure interaction on the structural control of nonlinear systems using adaptive control approach', *Engineering Structures*. Elsevier, 157, pp. 1–13.
- Attia, S. (2018) 'Evaluation of adaptive facades: The case study of Al Bahr Towers in the UAE', *QScience Connect*. Hamad bin Khalifa University Press (HBKU Press), 2017(2, Special Issue on Shaping Qatar's Sustainable Built Environment-Part I), p. 6.
- Babilio, E., Miranda, R. and Fraternali, F. (2019) 'On the kinematics and actuation of dynamic sunscreens with tensegrity architecture', *Frontiers in Materials*. Frontiers, 6, p. 7.
- Christian, S. (2015) *Best of Detail: Fassaden/Facades*. München: DETAIL; Bilingual edition (October 16, 2015).
- El-Zanfaly, D. E. E. (2011) 'Active shapes: introducing guidelines for designing kinetic architectural structures'. Massachusetts Institute of Technology.
- Elkhayat, Y. O. (2014) 'Interactive movement in kinetic architecture', *Journal of Engineering Sciences*, 42(3), pp. 816–845.
- Emami, N., Khodadadi, A. and Buelow, P. Von (2014) 'Design of Shading Screen Inspired by Persian Geometric Patterns: An Integrated Structural and Daylighting Performance Evaluation', in *Proceedings of IASS Annual Symposia*. International Association for Shell and Spatial Structures (IASS), pp. 1–8.
- Fard, M. S. (2015) *Dynamic structure designing adapted to sun radiation (integrated design process in islamic Architecture)*. Imam Reza university.
- Hassani, B., Tavakkoli, S. M. and Moghadam, N. Z. (2011) 'Application of isogeometric analysis in structural shape optimization', *Scientia Iranica*. Sharif University of Technology, 18(4 A), pp. 846–852. doi: 10.1016/j.scient.2011.07.014.
- Jamei, E. *et al.* (2017) 'Investigating the role of virtual reality in planning for sustainable smart cities', *Sustainability*. Multidisciplinary Digital Publishing Institute, 9(11), p. 2006.

- Jang, G.-W., Shim, H. S. and Kim, Y. Y. (2009) 'Optimization of support locations of beam and plate structures under self-weight by using a sprung structure model', *Journal of Mechanical Design*, 131(2).
- Knight, T. (2000) 'Shape grammars in education and practice: history and prospects', *International Journal of Design Computing*, 2(67).
- Moloney, J. (2011) *Designing kinetics for architectural facades: state change*. Taylor & Francis.
- O'Reilly, U.-M. and Hemberg, M. (2007) 'Integrating generative growth and evolutionary computation for form exploration', *Genetic Programming and Evolvable Machines*. Springer, 8(2), pp. 163–186.
- Ron, R., Weissenböck, R. and Harari, T. (2013) 'Kinetic Architecture Matrix', in *Proceedings of the International Conference on Adaptation and Movement in Architecture (ICAMA 2013)*, Ryerson University, Toronto, pp. 71–81.
- Schumacher, M., Schaeffer, O. and Vogt, M.-M. (2012) *Move: architecture in motion-dynamic components and elements*. Walter de Gruyter.
- Shea, K., Aish, R. and Gourtovaia, M. (2005) 'Towards integrated performance-driven generative design tools', *Automation in Construction*, 14(2), pp. 253–264.
- Sherbini, K. and Krawczyk, R. (2004) 'Overview of intelligent architecture', in *1st ASCAAD International conference, e-design in architecture Dhahran, Saudi Arabia*. Citeseer, pp. 137–152.
- Stiny, G. and Gips, J. (1971) 'Shape grammars and the generative specification of painting and sculpture.', in *IFIP Congress (2)*, pp. 125–135.
- Wang, D. (2004) 'Optimization of support positions to minimize the maximal deflection of structures', *International Journal of Solids and Structures*. Elsevier, 41(26), pp. 7445–7458.
- Wang, Q. and Teuffel, P. (2017) 'Adaptive structures and design concept of transformable joints', *International Journal of Design & Nature and Ecodynamics*. WIT Press, 12(2), pp. 235–245.
- Won, K.-M. and Park, Y.-S. (1998) 'Optimal support positions for a structure to maximize its fundamental natural frequency', *Journal of Sound and Vibration*. Elsevier, 213(5), pp. 801–812.

THE HOUSE CONFIGURATOR: CONFIGURING BIM VARIABLES USING GAME INTERFACES

Lilia Potseluyko Amobi

Teesside University, Middlesbrough, UK

Farzad Rahimian

Teesside University, Middlesbrough, UK

ABSTRACT: *To sharpen the competitive edge in the global market, manufacturers today ought to enable their customers to personalise their products and services. Mass customisation inherently offers the service of individualisation of goods and services to customers aiming at better meeting customers' personal needs. The user experience of personalising products by conducting product configuration is crucial for encouraging customer retention and loyalty in various sectors of the economy. The product configurators have been effectively deployed in the areas of automobile and smart products. However, very few successful attempts have been made to configure offsite manufacturing construction products due to the sector's fragmentation and parametric nature of the design elements. This project studied the product personalisation process of Timber Frame Self-Building Housing Sector by observing a design team communication with clients. By linking our results with the insights gained in the product configurator literature review, this study makes recommendations for the integration of the configuration user-interface design in the Offsite Construction Manufacturing Sector. The study developed multiuser configurators for different platforms, web-based and Virtual Reality based. The proposed approach has been developed through the synergies of advanced IT technologies, and openBIM principles have been proven to be valid. They should be a valuable reference in the future development of the product configuration system for offsite manufacturing in construction.*

KEYWORDS: *BIM, Configurator, Mass Customisation, Self-Build Housing, Unreal Engine 4.*

1. Introduction

The developer-led private housing sector currently builds most of UK residential homes. Throughout the design and construction processes, the final purchaser is typically unknown to the developer. The developer's short-term relationship with the homes they produce often resulting in poor quality design and specification decisions. Another continuously reported issue in the UK housing sector is the unmet demand in housing quantity in the UK (Heffernan and Wilde 2020) alongside the growing need to address the environmental sustainability of the new homes.

1.1 Self-Build Housing Sector in the UK

The alternative to developer-led private housing sector is the self-build housing sector, the form of housing, where the first homeowner is involved in its production, either by arranging for its construction or being involved in building it themselves to some degree. Bespoke houses in chosen locations also appeal to clients with an opportunity to save up to 30% on market value or optimise budget use, equip the house with high energy efficiency level and latest home technologies. Clients who undertake a self-build project would typically need to accomplish following tasks: finding a plot, agreeing on house design, cost calculation, attaining planning and building regulations permissions, deciding on finance, project management and others. The Timber Frame Kit Home Manufacturing Companies (TFKHMC) are one of the critical service providers in the sector. They offer a packaged range of services, which frequently include: conceptual and technical design, cost optimisation solutions, assistance in attaining relevant planning and building permissions, kit home manufacturing, shipping kit homes to the construction site, customer service and other forms of consultancy.

Despite multiple benefits, UK TFSBS is relatively small compared to its European and North American counterparts. The number of self-build projects per year in the UK fluctuates steadily between 10000 to 15000 items and accounts only to 7-10% of the UK's housing construction market, whilst this number reaches 80% in Austria, 60% in Canada and 50% in the USA, with the other countries having similar dispersion (Wilson 2017). The macro-level of the stagnation factors in the UK is a culture of the supply chain not being customised enough to cater to individual home builder's demands, difficulty in acquiring the land by individuals versus developer-led companies and educating the market about the process of the self-build.

The literature asserts that self-build homes are more likely to be environmentally sustainable than homes built by developer-led companies(Boonstra and Boelens 2011, Litfin 2014). Previous research identified the need to encourage more self-build methods of procurement, as a long-term solution to the low uptake of environmentally sustainable construction practices in the UK housing sector(Benson 2014, Heffernan and Wilde 2020). Therefore, there is a necessity to develop business models within the construction sector to promote self-building and optimise house configuration process depending on costing, sustainability, and unique awareness variables. Despite the importance of the sector as innovative model for zero-carbon housing, remarkably only few scholars(Pour Rahimian, Chavdarova et al. 2019) have focused their attention on applying BIM principles and game technologies to improve collaborative working and decision making in the sector.

1.2 Mass Customisation

The research studies focused on mass customisation (MC) have indicated increasing preferences in customisation of products and services(Mourtzis, Doukas et al. 2014, Deradajat and Minshall 2018, Ellena, Mustafa et al. 2018, Piroozfar, Farr et al. 2019). The scholars have suggested, consumers became more sophisticated and are aware of issues about the design, quality and functionality of their products and services. As a result, demand has been increasing for affordable and reliable products that correspond precisely to the specific needs of the purchaser(Papathanassiou 2004). MC of markets means that organisations can reach the same large number of customers as in the mass markets. Still, additionally, they can address their customers individually as in the customised markets.

In this paper, the Timber Frame Kit Home Manufacturing Companies (TFKHMC) are identified as Manufacturer seeking MC of their products and services via digital interfaces and the client is the potential purchaser of the Timber Frame Kit Home. The detailed analysis of the sales and manufacturing process in the industry implies focusing on two practical approaches in MC described by the scholars(Gilmore and Pine 1997, Papathanassiou 2004, Steger-Jensen and Svensson 2004). *The collaborative approach* suggests conducting a dialogue with individual customers to help them articulate their needs, to identify the particular offerings and customise the products. *The adaptive approach* implies that an organisation offers a standard but customisable product that is designed so that customers can alter it themselves.

The growing complexity of AEC projects involves multiple stages and variables(RIBA 2020): site information and spatial requirements; client requirements and project brief; project budget and cost plan; technical design and application of lean manufacturing principles; environment, social and economic sustainability outcomes. The past five years have seen further changes in the construction industry. Digital innovation continues to transform many aspects of project workflow, arguably moving towards a paradigm shift rather than a tweaking of more traditional ways of working. Modern methods of construction, including volumetric modular, are transforming the residential sector, pointing to new future business models.

Due to the reiterative project nature of the self-building housing sector, the empirical evidence from TFKHMC websites(HebrideanHomes 2020, Norscot 2020, Scotframe 2020) has demonstrated a wide variety of the template house options. The template designs represent each company's competitive edge in solving a classic challenge of finding optimal solutions in combination of aesthetic design, cost efficiency, lean manufacturing, and environmental sustainability principles. As a result, we aim to explore the *adaptive approach* for the Kit Home Template Designs customisation by presenting the available number of options using digital interfaces to ensure clients' participation in the visual and spatial design process.

1.3 BIM Configuration Variables

The impact of BIM on design can mostly be detected in the conceptual phase of a project as it supports greater integration and better feedback for early design decisions. It involves the construction level modelling including detailing, specifications and cost estimation, then the integration of engineering services and supporting new information workflows, and last but not least collaborative design-construction integration. The vital challenge of today for BIM impact is striking a balance between zero-carbon goals and the stimulation of growth in the housebuilding industry (Ares 2016, Martiskainen and Kivimaa 2018, Roggema 2019). Zero-energy housing suggests it requires a meagre amount of energy to provide the daily needs and functions for the family occupying the home; eliminate waste, optimise daylighting, incorporate the most efficient heating, ventilation and air conditioning systems(Nasrabadi Mahla and Hataminejad 2019). Accurate and timely cost feedback is critical for design decision-making on building construction projects. In the early phases of design, this is a significant challenge for estimators as they must create detailed and accurate cost estimates. However, the plan is still evolving and changing, and there is often incomplete information(Cohen, Aspary et al. 2013, Lawrence, Pottinger et al. 2014,

Li, Yang et al. 2014).

Unlike broad public and commercial architectural projects, small residential projects have limited timescale and budget for visualisation of each project; however, due to repetition and similarity in each cycle, there is an excellent potential for generative design. The primary focus in this paper is the variables related to house extensions, the configuration of window and door styles and materials in correlation with the total price.

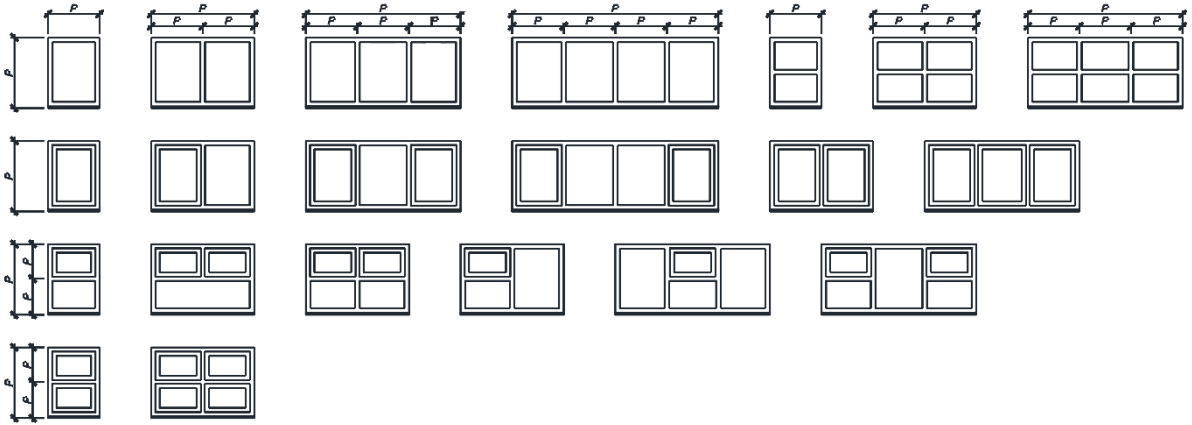


Fig. 1 Common Window and Door Styles in Self-Building Sector

1.4 Application of Game Design Principles

The success of the gamification of a virtual environment hugely depends on the ability to convey its context(Thompson, Berbank-Green et al. 2007, Schell 2008). The context of the current experience as a target for gamification is to provide effective sales process that includes better understanding between a client and a product/service provider. The effective sales process consists of the following stages(Viio and Grönroos 2016, Leclercq, Hammedi et al. 2018, Eisingerich, Marchand et al. 2019, Nasirzadeh and Fathian 2020). The preparatory stage one is when a salesperson acquires all the necessary knowledge about the product/service and clients background and motives. The first point of contact stage is characterised by building the rapport with the customer, providing a client with basic knowledge about the products/services without overwhelming them with the details at the initial stage. The next stage is designated for listening/questioning and objections handling, where the client is provided with more specific knowledge on request. At the last stage of the journey, the customer is provided with a detailed quote of a customised product. The sales techniques described in the literature also emphasised the importance of the comfortability of a client sales experience.

VR has the potential to provide experiences and deliver results that cannot be otherwise achieved. However, interacting with immersive applications is not always straightforward. The VR UX should work in an intuitive manner that is a pleasurable experience and devoid of frustration. It is up to designers to develop VR applications in a way that the users can achieve their goals elegantly and comfortably(Jerald, LaViola et al. 2017).

Unlike a staff member, who has to learn to navigate complex interfaces with ease by a job description, a client, on the contrary, is no under such obligation and could have a very different reaction towards virtual environments. The salesperson/construction/design specialist should be able to handle this complexity of the UI. However, the User Experience(UX) for a client should contain no discouraging complexities or should be guided by a salesperson.

Quality of VR experience is classified into two categories: scene of presence and sense immersion(Jerald 2016). Whereas immersion is about the characteristics of technology, presence is an internal psychological and physiological state of the user. The summarised characteristics of the quality of VR UX all detailed below(Wu, Chen et al. 2018, Bozzelli, Raia et al. 2019, Kim and Ko 2019, Somrak, Humar et al. 2019, Celikcan, Askin et al. 2020):

The frame rate is a minimum vital characteristic of the quality of the user experience. Majority of the sources

indicate 90fps as the comfortable minimum; nevertheless, with the steady technology improvements, particularly in the video cards capacity, other developers suggest a much higher number. Another essential characteristic here is the maintenance of the same level of the frame rate across a game experience as significant fluctuation may cause adverse user discomfort. A virtual representation which is as close to the product/building/environment as possible. Materials in the virtual world should simulate real-world material colours, reflective properties, and surface roughness characteristics. Lighting should simulate real lighting fixtures, colour temperatures, and shadow casting. In the past years (2017-2020), the market of VR/AR/MR headsets has significantly expanded, offering a variety of options from various manufacturers. The quality of the VR experience and the interface functionality significantly depends on the hardware and the platform of choice. As the VR for construction app vital purpose is to give users perception of space, all the objects in the VR environment should correspond to high fidelity accurate scale. By making interfaces intuitive with the simplest mental model possible can achieve the desired VR UX result. Other scholars emphasised on the importance of providing sensory cues (like haptic feedback) and audio cues (like sound effects) to cover a broader range of users across all modalities. Furthermore, in-game computer characters/instructors and multiuser experiences were proven to help users learn the same interactions.

1.5 Research Gap

The product configurators have been effectively deployed in the areas of automobile and smart products. However, very few successful attempts have been made to configure offsite manufacturing construction products due to the sector's fragmentation and parametric nature of the design elements. This project studied the product personalisation process of Timber Frame Self-Building Housing Sector by observing a design team communication with clients. By linking our results with the insights gained in the product configurator literature review, this study makes recommendations for the integration of the configuration user-interface design in the Offsite Construction Manufacturing Sector.

2. Materials and Methods

Comprehensive literature review stage has established the associations between MC, product configurators, BIM and latest software and hardware capabilities intending to investigate effective deployment of adaptive customisation approach in the Self-Build Sector. The software development has been split into three stages and has been driven by agile software development principles and methodology (Schwaber and Beedle 2002). The diagram below demonstrates the design thinking cycle or agile software development, where each new iteration of the cycle builds on the usability tests and reviews from the previous.

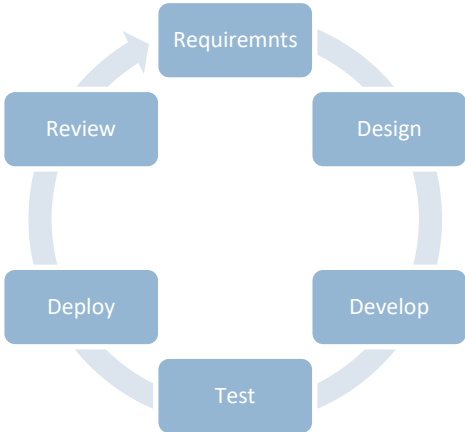


Fig. 2 Agile Software Development Methodology

The prototyping stages were focused on client-salesperson interactions and visual perception of the kit homes virtual space. The collected usability tests helped us to analyse feedback on how to improve the interface and suggest additional functionality for house configurator. During stage three, the final prototype was developed, which presented proof of concept house configurator using BIM variables and test results were validated.

The project used Norscot Joinery's kit home houses templates, which was the leading industry partner and one of the founders of this project. In the following sections of this paper, Norscot Joinery Ltd. will be referred to as Norscot.

2.1 Client study-based approach in identifying Configuration Variables

2.1.1 Prototype Kinraig: client spatial awareness, visual perception, and interactive objects.

Requirements. For stage one, one of the smallest house kit template designs was chosen to enable fast prototyping. The two-bedroom Norscot Kinraig template house was used to test some of the available BIM interoperability formants with the game engine software and identify the optimal workflow suitable for a small construction company with limited staff capacity dedicated to visualisation and development. The VR game engine experience was required to have basic walkthrough functionality and interactive objects. Client usability tests were conducted and reviewed to identify configuration variables.

Design/Develop. The original BIM model was remodelled in Autodesk Revit using linked Autodesk AutoCAD files. The tested interoperability workflows included: Revit(.fbx) =>game engine; Revit(.ifc) =>game engine; Revit (linked file import) => 3DS Max(.fbx) =>game engine. Each of the described workflows has demonstrated some form of data loss, need for manual object placement into correct positions, some forms of 3D objects distortion due to tessellation and triangulation and as a result, manual model adjustments using 3DS Max were required to improve visual perception of the models. Finally, with the development of Datasmith plugin for Unreal Engine 4, the new workflow was tested: Revit(.udatasmith) => Unreal Engine(UnrealEngine4 2020). The use of the plugin has enabled one-click interoperability workflow with the game engine. Each imported element of a model has preserved all metadata, materials and locations assigned in Revit. The plugin did not require additional cost expenses except the license cost of the Autodesk software, and the workflow was applicable for a small construction team. As a result, the Unreal Game Engine was identified as a primary software for developing the prototype.

The Kinraig prototype was developed using HTC Vive VR headset as a platform. The experience included teleportation interface, ability to pick up and move furniture, opening and closing doors, reflective mirrors.

Test/Deploy/Review. Initially, 75 usability tests were conducted. 32% of the participants were classified as frequent game players, other 35% were classified as potential clients, and construction industry professionals represented the remaining 33%. The test result suggestions include the statements below. Diegetic interfaces and interactable game objects ideal for the first point of contact with the client to attract attention and as 'icebreakers' and conversation starters, which are essential elements of the initial sales process. However, on the detailed stage of the design review, the more standard interface is required. The frequently purchased house template 'Kinraig' was commonly aimed to be a holiday home design, the typical house customisations highlighted by previous clients were the removal of the wall between the living room and the kitchen (highlighted in the image in purple), bedroom extensions and size of the entrance space(highlighted on the image in blue). The users suggested the capability of viewing the common design extension variations.

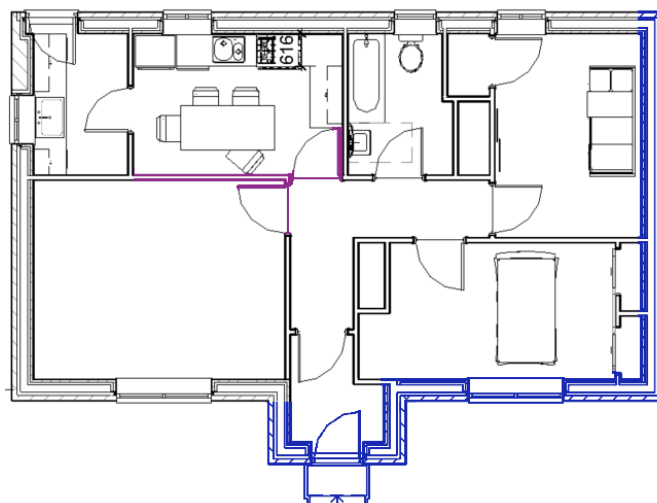


Fig. 3 Kinraig House template. Walls highlighted in purple commonly removed by the clients. Walls highlighted in blue present common Exterior extension borders.

Furniture in the house served as a sensible space perception guide for the clients. The participants were repositioning the furniture to imagine different setup or remove furniture entirely to reimagine the space. Moving each furniture piece individually in the virtual space was perceived as a cumbersome and tedious task—the new method of manipulating interior setups needed to be proposed. The use of the VR experiences in mainstream daily households has not yet reached its momentum, some discomfort and apprehension in using and trying VR experiences by various participants needed to be anticipated and addressed. Many participants experienced various forms of disorientation in virtual space. One participant had mild immobility in their fingers, which prevented them comfortably pressing buttons on the VR Controller. The following prototyping stage also aimed to consider known types of disability and propose solutions accordingly. Several participants requested for the feature of customising exterior variables house facades, roof styles and day/night scenarios.

2.1.2 Prototypes: Montrose, Tait, Souter. Teleport menu and proof of concept door customisation interface.

Requirements. "The exhibition template" VR experience was proposed for development to respond to the gamification of the interaction of the first point of contact with the client and application of 'B2B'(conversion browser to the buyer) techniques in VR. However, the description exhibition prototype is out of the scope of this paper, as the primary focus of this study is the detailed design discussion and development of the BIM variables. Other requirements included testing of the various options of teleport menu UI to support user's orientation and navigation in virtual space; testing various options of interior design representation to support user's spatial perception; selecting one of the BIM variables and testing as proof of concept prototype for future house configurator.

Design/Develop. Prior to the development, several VR architectural walkthroughs and gaming experiences(Immersion 2017, Innoactive 2018) were tested to propose various options of the teleport menu. Based on the review of the game experiences, the developed options included teleport systems as shown on the image.

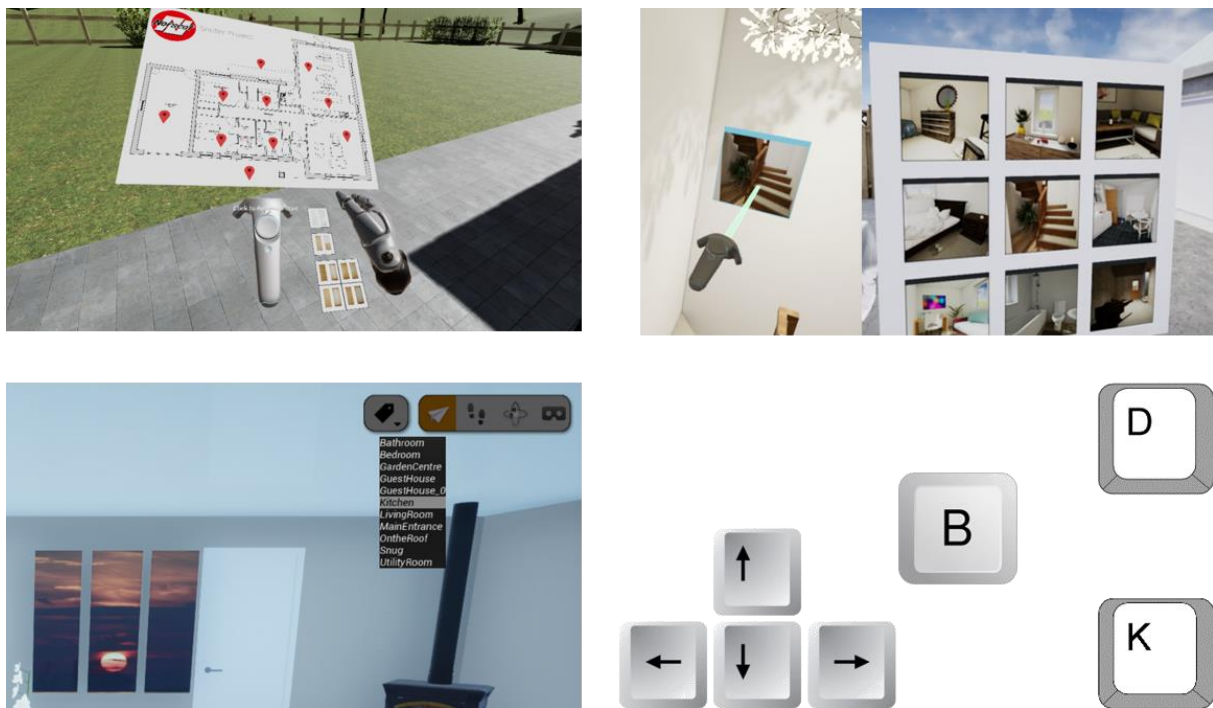


Fig. 4 Teleport menu systems left to right: (1) motion-controller-attached 2D floor plan with teleport locations, (2) location-based menus with images of teleport options and return to start button, (3) scroll menu with room names and teleport destinations. In addition, (4) keyboard shortcuts for teleport locations were created to be used by sales consultants outside VR experience to assist participants teleportation in VR.

For the development of the interior UI, various furniture sets were created for each room, context-based 3D widgets were used to enable switching from one interior option to another and an empty room. Also, for each bedroom, the size-changing bed UI was proposed to determine which size of the bed would fit in a room in correlation with a remaining void and if further room extensions were required.



Fig. 5 Interior UI prototyping. Left to right (1) Changing size bed; (2) UI for adding and removing interior

For the proof of concept BIM variable, Norscot interior door designs selection was used. The sales algorithm for door selection was examined. The door changing variables included style, material, and matching glass door design. The door metadata was carefully studied, and the pathways of utilising metadata for quantification filtering were suggested.

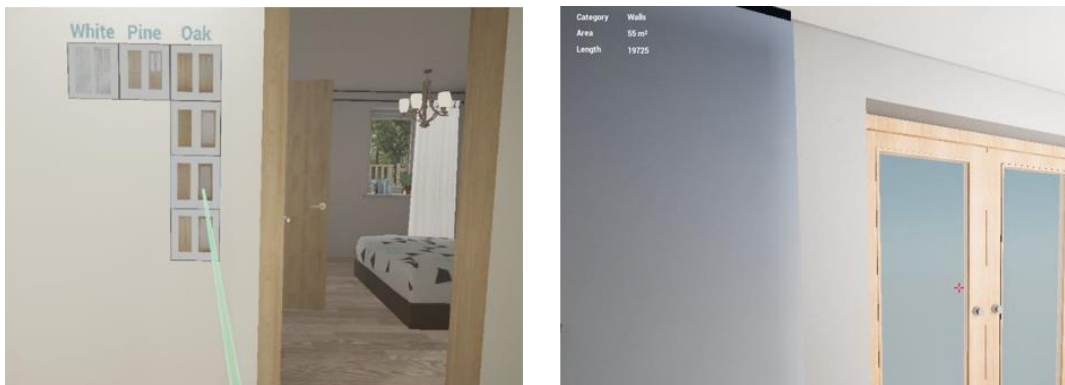


Fig. 6 Development of the Door Configurator

Test/Deploy/Review. The usability tests for this stage included two life kit home design cases with clients; 7 Norscot design and sales professionals; 45 industry professionals and peers. In summary, the use of teleport locations menus significantly improved sense of direction in VR space. The scroll menu enabled alphabetical search of the locations. The floor plan menu significantly helped life project clients to establish a connection between the floor plan and actual space. Additional images with the locations helped clients to navigate to previous locations and the start point. The keyboard shortcuts were effectively used to aid the users in the VR experience. Ideally, all four teleport menu types should be included in VR experience. Hypothetically, due to the limited time scale and workforce available in the experiment, it would present a challenge to add all four elements in each new design. Use of the furniture as a space measurement tool has proven to be useful in life projects. The Clients were able to judge effectively if extension or downscaling needed. The proof of concept door interface was useful in presenting the company door range, however further development required and connection with costing data and metadata filtering. One of the common repetitive workflows included placement of interior objects and decorations into the scene, garden creation and lighting scenarios. Pre-made optimised sublevels library should be suggested. Further effort was required to create universal and dynamic UI with less customisation for each new design as possible.

2.1.3 House Configurator

Requirements. The house configurator utilised knowledge and experience developed in previous prototyping stages and was focused on automating repetitive workflows and utilising quantification and costing data. To minimise repetition, the sub-levels library was required.

Design/Develop. The house configurator was developed using Unreal Engine 4 Collaboration Viewer Template(UnrealEngine4 2020) with extended functionality added for House Configurator.

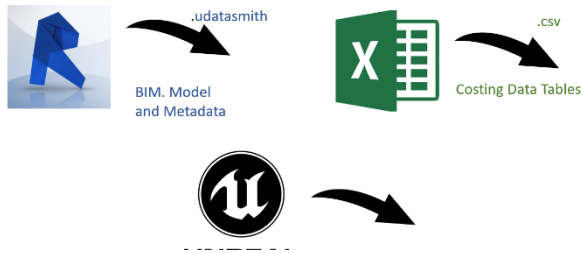


Fig. 7 House Configurator Workflow Elements

The template allows developing prototypes with multiuser support for multiple platforms and allows for sessions to be saved and viewed later with further adjustments (measurements, object positions and annotations). The dynamic lighting system was used as it allows much faster workflow for prototyping. The designed interface variables were divided into two groups (1) visual and spatial variables presented in columns Interior and Exterior UI; (2) cost affecting variables presented in Interior and Exterior Door Controls. By making changes in cost affecting variables, clients were able to see an overall change to the total price.



Fig. 8 House Configurator. Exterior variables examples. Rows from top to bottom: (1) Façade Styles; (2) Lighting Scenarios; (3) Garden options; (4) Window materials; (5) Roof variables.

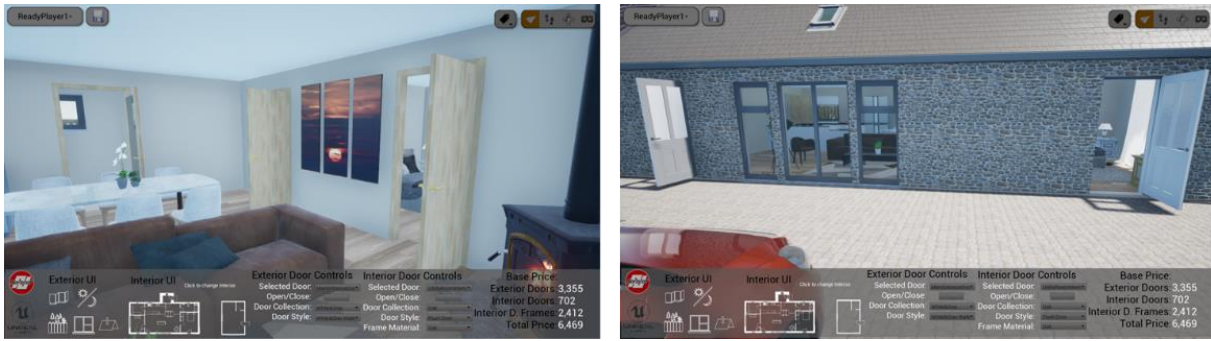


Fig. 9 Door configurator Interface.

In addition, the script was created for interior and exterior doors configuration. The doors were swapped using the automated recipe, and scripted door interface was automatically added both to 3D view and user interface. The script utilised data table with the company's door pricing figures.



Fig. 10 House Configurator Interior Changing UI Examples.

Test/Deploy/Review. The usability tests were conducted at this stage ease of modification of the template by the staff members. Ten days training was presented to 5 staff members with the previous skillset in architecture and drafting. After training was completed, the staff members were able to customise the template independently, and each house configurator took on average 4 hours to complete. The review by peers and staff members has shown users being more comfortable in navigating house configurator in desktop mode and switching to VR once changes are implemented. It was suggested to explore further adding other BIM/ quantification variables, including window materials, house extensions. The interface could be further extended to add detailed quantification.

3. Conclusion and Future Work

The emphasis within this paper is on individual self-building projects; however, gained knowledge could be transferred into group and community self-build projects. Detailing the house configurator functionality making parametric changes might lead to mimicking Revit functionality. Instead, further research needs to be implemented to predict common configurations and apply adaptive mass customisation approach. The future house configuration should focus on data mining and machine learning generative design.

4. Acknowledgements

The authors wish to gratefully acknowledge the generous funding received from InnovateUK, Norscot Joinery Ltd to support this study as a part of the Knowledge Transfer Partnership hosted by the University of Strathclyde, Glasgow. The authors also would like to acknowledge contributions of all people involved in this study, especially Dr Ian Heywood (Knowledge Transfer Adviser, InnovateUK) and Jason Fraser (Technical Operations Manager, Norscot Joinery Ltd) for providing Business and Technical Guidance.

5. REFERENCES

- Ares, E. (2016). House of Commons Library. Zero Carbon Homes.
- Benson, M. (2014). Creating a nation of selfbuilders: An interim report from the project Selfbuilding: the production and consumption of new homes from the perspective of households, London: Goldsmiths University of London.
- Boonstra, B. and L. Boelens (2011). "Self-organization in urban development: towards a new perspective on spatial planning." Urban Research & Practice **4**(2): 99-122.
- Bozzelli, G., A. Raia, S. Ricciardi, M. De Nino, N. Barile, M. Perrella, M. Tramontano, A. Pagano and A. Palombini (2019). "An integrated VR/AR framework for user-centric interactive experience of cultural heritage: The ArkaeVision project." Digital Applications in Archaeology and Cultural Heritage **15**: e00124.
- Celikcan, U., M. B. Askin, D. Albayrak and T. K. Capin (2020). "Deep into visual saliency for immersive VR environments rendered in real-time." Computers & Graphics **88**: 70-82.
- Cohen, J. D., K. E. Aspary, A. S. Brown, J. M. Foody, R. Furman, T. A. Jacobson, D. G. Karalis, P. M. Kris-Etherton, R. LaForge, M. F. O'Toole, R. D. Scott, J. A. Underberg, T. B. Valuck, K.-E. Willard, P. E. Ziajka and M. K. Ito (2013). "Use of health information technology (HIT) to improve statin adherence and low-density lipoprotein cholesterol goal attainment in high-risk patients: Proceedings from a workshop." Journal of Clinical Lipidology **7**(6): 573-609.
- Deradjat, D. and T. Minshall (2018). "Decision trees for implementing rapid manufacturing for mass customisation." CIRP Journal of Manufacturing Science and Technology **23**: 156-171.
- Eisingerich, A. B., A. Marchand, M. P. Fritze and L. Dong (2019). "Hook vs. hope: How to enhance customer engagement through gamification." International Journal of Research in Marketing **36**(2): 200-215.
- Ellena, T., H. Mustafa, A. Subic and T. Y. Pang (2018). "A design framework for the mass customisation of custom-fit bicycle helmet models." International Journal of Industrial Ergonomics **64**: 122-133.
- Gilmore, J. H. and B. J. Pine (1997). "The four faces of mass customization." Harvard business review **75**(1): 91-102.
- HebrideanHomes (2020). "Kit Homes Designs."
- Heffernan, E. and P. d. Wilde (2020). "Group self-build housing: A bottom-up approach to environmentally and socially sustainable housing." Journal of Cleaner Production **243**: 118657.
- Immersion (2017). TrueScaleVR.
- Innoactive (2018). VR Kitchen Experience.
- Jerald, J. (2016). "The VR Book : Human-centered Design for Virtual Reality / [internet Resource]. ACM Books ; #8. Web."
- Jerald, J., J. J. LaViola and R. Marks (2017). VR interactions. ACM SIGGRAPH 2017 Courses. Los Angeles, California, Association for Computing Machinery: Article 19.
- Kim, D. and Y. J. Ko (2019). "The impact of virtual reality (VR) technology on sport spectators' flow experience and satisfaction." Computers in Human Behavior **93**: 346-356.
- Lawrence, M., R. Pottinger, S. Staub-French and M. P. Nepal (2014). "Creating flexible mappings between Building Information Models and cost information." Automation in Construction **45**: 107-118.
- Leclercq, T., W. Hammedi and I. Poncin (2018). "The Boundaries of Gamification for Engaging Customers: Effects of Losing a Contest in Online Co-creation Communities." Journal of Interactive Marketing **44**: 82-101.
- Li, N., Z. Yang, A. Ghahramani, B. Becerik-Gerber and L. Soibelman (2014). "Situational awareness for supporting building fire emergency response: Information needs, information sources, and implementation requirements." Fire Safety Journal **63**: 17-28.

- Litfin, K. T. (2014). Ecovillages: Lessons for sustainable community, John Wiley & Sons.
- Martiskainen, M. and P. Kivimaa (2018). "Creating innovative zero carbon homes in the United Kingdom — Intermediaries and champions in building projects." Environmental Innovation and Societal Transitions **26**: 15-31.
- Mourtzis, D., M. Doukas, F. Psarommatis, C. Giannoulis and G. Michalos (2014). "A web-based platform for mass customisation and personalisation." CIRP Journal of Manufacturing Science and Technology **7**(2): 112-128.
- Nasirzadeh, E. and M. Fathian (2020). "Investigating the effect of gamification elements on bank customers to personalize gamified systems." International Journal of Human-Computer Studies **143**: 102469.
- Nasrabadi Mahla, T. and H. Hataminejad (2019). "Assessing sustainable housing indicators: a structural equation modeling analysis." Smart and Sustainable Built Environment **8**(5): 457-472.
- Norscot. (2020). "Norscot Kit Homes." from <https://www.norscotkits.co.uk/>.
- Papathanassiou, E. A. (2004). "Mass customisation: management approaches and internet opportunities in the financial sector in the UK." International Journal of Information Management **24**(5): 387-399.
- Piroozfar, P., E. R. P. Farr, L. Hvam, D. Robinson and S. Shafiee (2019). "Configuration platform for customisation of design, manufacturing and assembly processes of building façade systems: A building information modelling perspective." Automation in Construction **106**: 102914.
- Pour Rahimian, F., V. Chavdarova, S. Oliver, F. Chamo and L. Potseluyko Amobi (2019). "OpenBIM-Tango integrated virtual showroom for offsite manufactured production of self-build housing." Automation in Construction **102**: 1-16.
- RIBA. (2020). "Plan of Work 2020. Overview." from <https://www.architecture.com/-/media/GatherContent/Test-resources-page/Additional-Documents/Printfriendly2020RIBAPlanofWorkoverviewpdf.pdf>.
- Roggema, R. (2019). "Towards sustainable cities: about redundancy, voids and the potentials of the land." Smart and Sustainable Built Environment **9**(3): 283-306.
- Schell, J. (2008). The Art of Game Design: A book of lenses, CRC press.
- Schwaber, K. and M. Beedle (2002). Agile software development with Scrum, Prentice Hall Upper Saddle River.
- Scotframe (2020). "Kit Home Designs."
- Somrak, A., I. Humar, M. S. Hossain, M. F. Alhamid, M. A. Hossain and J. Guna (2019). "Estimating VR Sickness and user experience using different HMD technologies: An evaluation study." Future Generation Computer Systems **94**: 302-316.
- Steger-Jensen, K. and C. Svensson (2004). "Issues of mass customisation and supporting IT-solutions." Computers in Industry **54**(1): 83-103.
- Thompson, J., B. Berbank-Green and N. Cusworth (2007). Game design: Principles, practice, and techniques-the ultimate guide for the aspiring game designer, John Wiley & Sons.
- UnrealEngine4. (2020). "Collaborative Viewer Template." from <https://docs.unrealengine.com/en-US/Resources/Templates/CollabViewer/index.html>.
- UnrealEngine4 (2020) "Datasmith Supported Software and File Types."
- Viiio, P. and C. Grönroos (2016). "How buyer–seller relationship orientation affects adaptation of sales processes to the buying process." Industrial Marketing Management **52**: 37-46.
- Wilson, W. (2017). "Self-build and custom build housing (England)." House of Commons Library.
- Wu, S., X. Chen, J. Fu and Z. Chen (2018). "Efficient VR Video Representation and Quality Assessment." Journal of Visual Communication and Image Representation **57**: 107-117.

Part3. Digital Twins

DIGITAL TWIN USES CLASSIFICATION SYSTEM FOR URBAN PLANNING & INFRASTRUCTURE PROGRAM MANAGEMENT

Ramy Al-Sehrawy, Bimal Kumar and Richard Watson

Northumbria University, UK

ramy.alsehrawy@northumbria.ac.uk

ABSTRACT: *Failure of traditional project management concepts and methods to cope with the increasing complexity, spatial and temporal scales of projects, has led to emergence of the distinct discipline of Program Management (PgM). Armed with a holistic approach and awareness of interdependencies, commonalities and synergies between projects, PgM attempts to better integrate between strategic intents and the outcomes of projects, and to realize benefits that cannot be obtained from managing these projects separately. On the other hand, the evolving concept of ‘Digital Twin’ has been recently gaining ground in the (AECO) sector. The idea of a National Digital Twin (NDT) in the UK is promising enormous value out of openness and sharing of city infrastructure data, which can heavily support the understanding of interdependences between infrastructure sectors and breakdown silos between the various urban systems. The mutual systemic thinking underlying both – discipline of PgM and idea of NDT – paves the way for the latter to heavily support the former in advancing, maturing and attaining the goals it is adopted for, through a diverse range of uses throughout a program’s lifecycle. However, the ‘DT uses’ demonstrated amongst literature are ad-hoc, tailored to the particular case at hand and customized merely to suit the local and individual needs of each study; thus, hindering the transfer or reuse of knowledge created by one case to another. Therefore, this paper seeks to formulate a seed for a DT Uses Classification System [DTUCS] within the field of urban and city infrastructure PgM. DTUCS is built through a simplified ontology development methodology along with analysis of the DT uses identified in relevant literature. It provides an initial step toward the establishment of a common, standardized structure, language and terminology that can be harnessed to precisely communicate the exact purpose and context of a DT usage in an urban program and DT procurement processes. The aim is to help promote the knowledge about the uses of DT generated by any case or project – including our ongoing studies and future research – to public knowledge rather than local or ad-hoc ones, in order to maximize its application to other studies and contexts.*

KEYWORDS: *Digital Twin, uses, classification, urban, city, infrastructure, program management.*

1. Introduction

The evolving concept of ‘Digital Twin’ [DT] has been recently gaining ground in the ‘AEC’ sector as it promises a huge potential to unlock and deliver value at a wide-ranging scale from individuals to whole cities at national level. A comprehensive definition of the term DT is given by a recent study (Al-Sehrawy & Kumar, 2021, p.926), describing the DT as “the Concept of connecting a physical system to its virtual representation via bidirectional communication (with or without human in the loop) using temporally updated Big Data...to allow for exploitation of Artificial Intelligence and Big Data Analytics by harnessing this data to unlock value...”. Throughout the extended journey of digitalizing the built environment, starting from CAD followed by the shift to BIM; DTs represent the latest wave, which is argued to promise a great potential and value to AEC industry, especially at the large city and urban scale which preceding waves have barely touched.

Nonetheless, the DT initiatives, case studies and pilot projects carried out so far are argued to be ad-hoc and mainly improvised. Indeed, one cannot argue with the voices calling for tailoring a project-specific DT strategy, which defines how a DT is built and used within the application at hand, in a customized way to offer a bespoke solution within a unique situation or organization. However, one must argue for doing so with reference to a common standardized language that allows for sharing knowledge, exchanging information, ensuring mutual understanding and facilitating processes such as procurement or publishing of DTs. This is expected to support users of DTs to overcome the common challenge, usually encountered by planners at early stages of the program, concerned with identifying and reaching a consensus about the most appropriate uses of a DT while tackling some sort of a unique DT application.

It is worth now to differentiate between three terms: ‘DT benefit’, ‘DT application’ and ‘DT use’. The DT benefits are the aims or end goals a DT can generally deliver whenever properly and effectively implemented; this may include some benefits such as: reducing construction and operating costs, increasing productivity and collaboration,

improving safety, optimizing sustainability and improving resilience [theiet, 2019]. A DT application denotes for the bespoke adoption of a DT within a unique situation (i.e. project, program or intervention) in order to realize one or more of the DT benefits. A DT use though is the standard or common method by which a DT is typically adopted to achieve a specific objective; in other words, a DT application is an integrated set of a multiple DT uses brought together to fit the unique situation or problem dealt with. In a nutshell, the DT use is the basic, elementary unit of DT applications undertaken to realize promised DT benefits. Accordingly, this paper proposes a seed for a 'DT Uses Classification System' [DTUCS] aiming to provide a clear scheme or method through which DT 'Uses' are recognized, classified, articulated and communicated amongst DT researchers, practitioners and stakeholders with a particular focus at the field of urban and city infrastructure interventions.

This paper is divided into five sections. The first section included the above introduction while the second section explains the methodology adopted to develop this study. The third section gives a brief description, including an outline, of the proposed DT classification system and its major constituents. The fourth section provides a thorough examination of the various 'purposes' of DT uses, which is argued to be the primary constituent of the DT Uses Classification System'. The final section concludes this paper albeit not the full study being a part of a currently ongoing research, yet it highlights the focus of future research working on further developing the system proposed herewith.

2. Research Methodology

DTUCS is developed using a simplified ontology development methodology. The method used comprised the following five general steps as shown in Figure 01:

The first step involves defining the domain and scope of the envisaged classification system. Competence questions addressed at this stage included: which domain should be covered by the ontology?; what is the purpose of the ontology for which it should be used for? and what sorts of questions will the knowledge represented in the ontology should answer?

The second step is to ascertain whether any ontologies (i.e. classification systems) were previously developed within the same domain. Drawing from or adapting to existing and well-established ontologies indeed has several advantages. It saves time and effort consumed in the process of building new ontologies. Building over ontologies or systems existing within the domain helps the domain's practitioners to easily digest the new system; it further ensures consistency with the well-known and widely accepted practices they usually adopt. Furthermore, it moves an extra step towards validation, since existing and well-established ontologies have already gone through severe checks and refinement through their applications (Kreider & Messner, 2013).

The third step is to enumerate terms. A pool of terms was documented using literature qualitative content analysis¹ along with brainstorming and gaining insights from other previously developed systems identified in step 2 (e.g. BIM Uses Classification Systems). During this process, only the purpose behind the use of a DT was considered, since it is viewed to be the fundamental characteristic of any DT use as argued in section 3.

In the fourth step, the listed terms were then grouped based on mutual and shared properties inherited by those terms and the defined class to which they belong. A mixed method of top-down, bottom-up, middle-out approaches were used back and forth between the higher classes and the lowest level terms.

Fifth and final step is mainly concerned with documenting the classification system and providing, in parallel, some instances of the common DT practices to help mapping such practices onto the system and show the system is capable of addressing the competency questions raised in step 1, and thus add an extra degree of validation.

¹ These terms were extracted as a part of a broader research including a systematic literature review of studies and manuscripts involving DTs in the realm of urban planning and city infrastructure decision making.

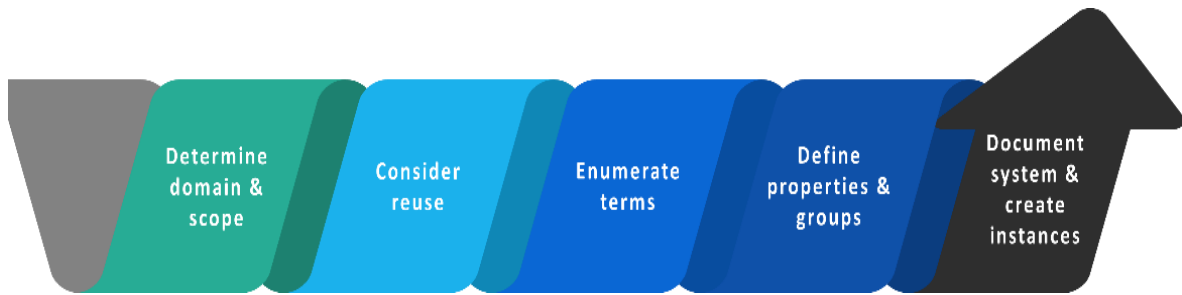


Figure 01: Five steps of the adopted simplified ontology development methodology

3. DT Use Classification System

Whilst the introduction in section 1 delineated the domain and scope as required by step 1 of the methodology (fig.01), we shall draw, as recommended by step 2, on the relevant parts of BIM Uses classification systems (Kreider & Messner, 2013) which are found to have multiple uses in common with DT Uses, rather than building our system from scratch. As argued by these BIM Use classification systems, which we believe is the case for DTUCS, the purpose of the BIM/DT Use is the primary feature or characteristic that distinguishes these uses. The DT Use is therefore classified primarily by its purpose. In addition, some other features beyond the use purpose are deemed necessary for the precise differentiation between various DT uses, on top of all is the program stage lifecycle, (i.e. definition, deployment, closure) (Thiry, 2015). Figure 02 is a conceptual illustration of the proposed DTUCS.

The idea of shifting to program lifecycle rather than project lifecycle referring represents the genuine move from BIM to DT. The point of adopting a program's view rather a project's view is more of intellectual rather than technical. It is to emphasize the systemic dimension of management in opposition to the isolated management of interventions in real world system of systems, such as city infrastructure. the systemic thinking of DT and the emphasis it put on the significance of relationships and interdependencies has brought the Program management [PgM] school to the center of the stage, replacing the siloed project management thinking. Subsequently, PgM lifecycle stages are used to more precisely specify the DT Use beyond the primary purpose. To put this differently, if we shall make a substantial move from BIM to DT as a way of thinking, and not just a technological advancement, this move must then include transitioning beyond the systematic siloed project management thinking to the systemic cross-boundary PgM thinking.

4. DT Use Purposes

As discussed in section 3 above, while the DT use purpose is the core of DTUCS and the fundamental characteristic to distinguish DT Uses; this section is purely dedicated to examining all derived from the enumerated and documented terms extracted according to the adopted methodology explained in section 2. The collection of DT Use purposes is divided into 4 major identified groups comprising 14 purposes from which 3 are further divided into 2 sub-purposes each (figure 02).

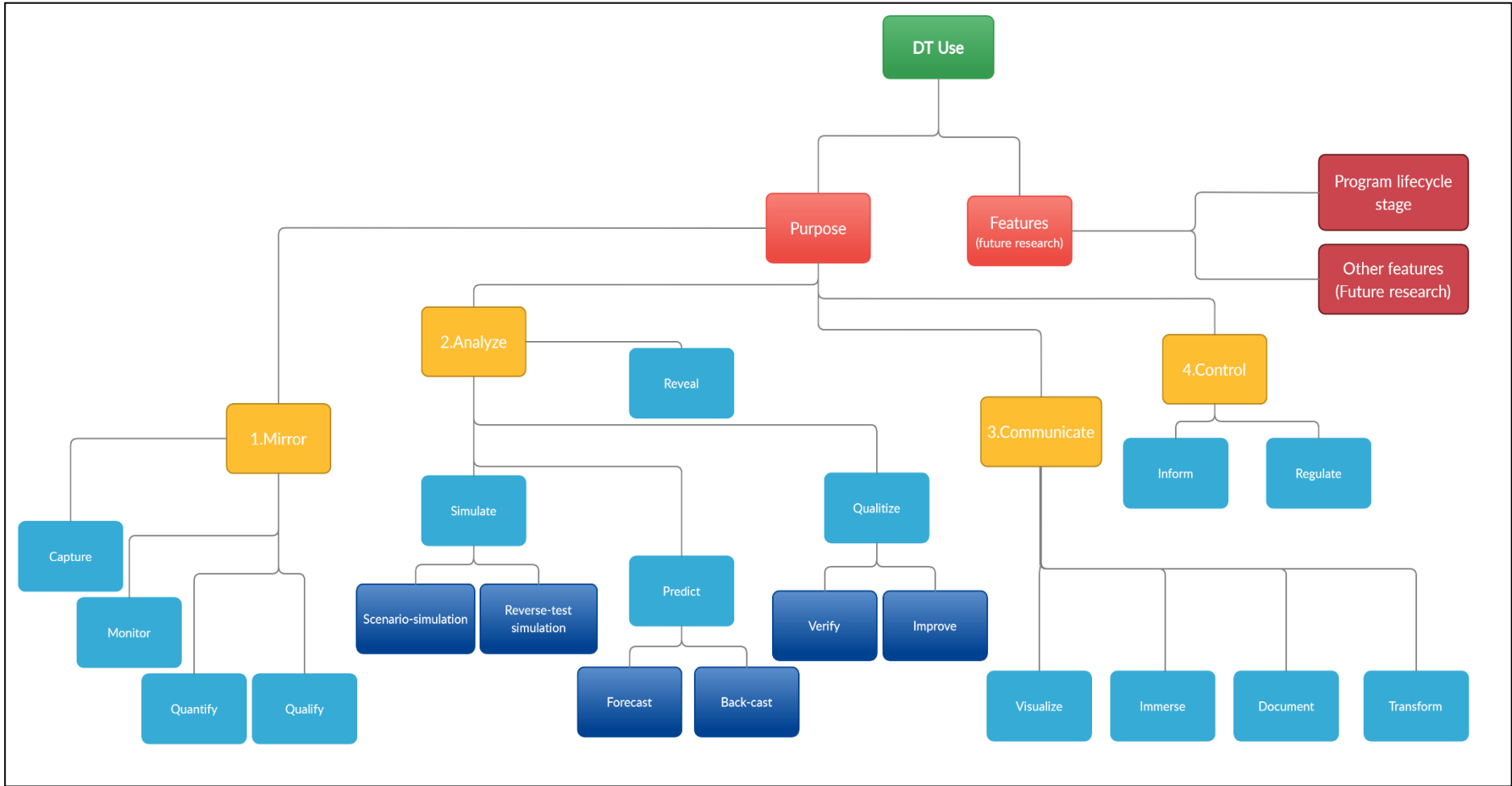


Figure 02: Conceptualization of the Digital Twin Uses Classification System [DTUCS]

4.1 Mirror

The idea of a DT is first and foremost concerned with mirroring or duplicating a physical system of interest operating in the real world to a virtual system in the cyber world (Al-Sehrawy & Kumar, 2021). In this group of DT Use purposes, the meanings derived from the gathered data or their implications on decision making or future interventions are irrelevant; rather, the sole objective is to sense and collect data including the information they carry, as produced by the physical system, for a specific application or objective in mind. Thus, the sensed data must then represent some level of abstraction of reality determined according to the goal in mind. Hence, the ‘Mirroring’ is about a mere creation of a model or a shadow of the observed real entity (Kritzinger et al., 2018). It is quite often for this group to establish an initial step in a designed series of DT Uses. This group is divided into 4 categories: capture; quantify; monitor; and qualify as shown in table 1.

4.1.1 Capture

DTs are used to capture the status of a physical system at specified point(s) of time using variant methods, including but not limited to laser scanners, photogrammetry, morphological structure, demographic or geographic surveys...etc. The common factor within uses of this purpose is that collected data are mostly historic, static or discrete and akin to straightforward recording of the information available in reality. For instance, a study by (Boeing, 2019) captured big data of urban forms and morphological structures extracted from few popular cities as a part of DT application.

4.1.2 Monitor

In this purpose, data related to the performance of a physical system over time are being mirrored on a virtual system in real-time. The digital outcome is a relatively dynamic set of connected and continuous flow of data streams. It is worth to highlight though that the notion of real-time is a flexible one (Wan, Yang & Parlikad, 2019); whereas only the objective in mind driving our intentions to build a DT is responsible for defining the temporal resolution or the frequency by which data within a virtual system gets updated against its physical counterpart in real world. It is in this purpose of DT uses where data is usually collected to support relatively short-term applications such as crisis, emergency or operational management and planning tasks.

4.1.3 Quantify

DTs can be used to count or capture quantities of physical system’s elements, particulars, instances or incidents. The measured quantities are defined in terms of the elements or units identified within the physical reality which are based on the determined scale and granularity of the DT. For example, this may include acquiring static data like historic statistical records or censuses during the formulation stage of an urban program; or more dynamic data at a defined temporal granularity such as daily number of commuters or the hourly rate of energy consumption during a program’s deployment stage.

4.1.4 Qualify

For this purpose of DT Use purpose, the DT is adopted to track the status, condition or mode of a physical system. A case of a discrete tracking of a physical system’s state may involve monitoring the operational condition of traffic lights, whether it is functioning or not, while a more dynamic case may include the qualification of a bridge by the continuous monitoring of its structural health throughout its lifespan (Butler et al. 2019).

Table 1: Purposes of the DT Use group 1: ‘Mirror’.

DT Use Purpose	DT Use Purpose definition	Synonyms
01 Mirror	To duplicate a physical system in the real world in the form of a virtual system in the cyber world.	Replicate, twin, model, shadow, mimic
1.1 Capture	Express in a digital format within the virtual world the status of a physical system at a point of time.	collect, sense, scan, survey, digitalize
1.2 Monitor	Collecting information related to the performance of a physical system.	Observe
1.3 Quantify	Measure quantity of a physical system’s particulars, instances or incidents.	Quantify, measure, takeoff, count

4.2 Analyze

This group of DT Uses is fairly argued to be the one through which the greatest value of a DT can be unlocked and realized. It allows for DT owners, users and various stakeholders to leverage the data gathered by the virtue of the achieved group 1 DT Use purposes, in order to be further processed and exploited in order to provide support in planning and decision making and generate new meanings, insights and knowledge. This may occur through one or more of the four purposes forming the ‘analyze’ group 2 of DT Use purposes: reveal; simulate; predict and verify as shown in table 2.

4.2.1 Reveal

This purpose is mainly concerned with utilizing big data gathered by adopting any of the DT Uses described in group 1 (table 1) in order to create new insights and possibly push the boundaries of knowledge and deepen the understanding about a physical entity or a complex sociocultural-economic system of systems like cities. Drawing on the work of Kitchin (2014) this purpose is the core of what is known as the ‘4th paradigm of science’, heavily relying on the mining of ‘big data’, artificial intelligence techniques and big data analytics to uncover underlying patterns and regularities with an unprecedented capability of eliminating human bias. The powerful analysis of the enormous amount of big data, can thus offer an unprecedented resolution of world’s phenomena. Theoretically validated body of knowledge may still be used to guide this endeavor of data-driven research and discoveries, including the guidance in collecting, managing and processing this big data and interpreting the output in a meaningful way. A recent study prompted by Centre for Digital Built Britain [cddb] (Whyte et al. 2019) demonstrates an interesting attempt in using a DT to generate new insights that may lead to a deeper grasp of systems relationships and interdependencies in terms of identifying, prioritizing, and managing them.

4.2.2 Simulate

In this purpose, computational methods and state-of-the-art techniques are used to explore and discover the implications and possible emerging behaviors of a complex web of interconnected variables recognized from the data gathered from the real world. In terms of DT uses, two distinct approaches within this purpose of simulation are identified. We shall fall back on the framework for resilience, recently published by the National Infrastructure Commission [NIC] (NIC, 2020) to elaborate both sub-purposes. The first is scenario-simulation; it mainly relies raising ‘what-if’ questions through having predefined scenario(s) prior to simulation, whether derived from a proposed plan or commonly expected risks and hazards. For instance, it may help better understand how infrastructure system of systems may react to expected shocks and stresses. Learning from the financial sector, the second approach is a ‘reverse-test’ simulation; the idea of this type of simulation is to question the system per se, rather than questioning a posited plan or an expected scenario. It is essentially concerned with making use of the virtual system to determine the ‘breaking point’ of its physical counterpart, akin to ‘destructive’ testing – the one question it seeks to address is: ‘what does it take for this system to fail or breakdown?’.

4.2.3 Predict

A DT can be used to predict the future state of a mirrored physical system. This purpose as well can be pursued through two discordant approaches: forecasting or backcasting (Bibri, 2018). The former is used to predict the most likely state of a real system in the future, by projecting the known current trends forward over a specified time horizon. The latter, however, is more concerned with answering, in a prospective manner, the question of ‘how’ a desirable envisaged future can be attained, rather than the question of ‘what’ future is likely to occur addressed by forecasting in projective manner. Backcasting, therefore, is typically used as a part of active intervention aiming for a desirable state.

4.2.4 Qualitize

This purpose of DT Uses deals with standards such as building codes, environmental assessment methods, resilience standards...etc. This purpose too includes two sub-purposes: verify and improve. A DT can be used to verify or validate a plan, design or an intervention in terms of current standards. This for instance include a myriad of studies attempting to ensure following Indoor Air Quality (IAQ) standards under different scenarios and operational circumstances (Rogage et al. 2019). Another purpose for a DT use is highlighted in the report developed by Arup (2019, p. 39) suggesting that in the near future a DT will be “able to inform the future planning and designing...on what has actually been used as opposed to designed based upon standards.”. This indeed

demonstrates a considerable value added by the idea of a DT compared to BIM. While some applications and uses of BIM include the check of design against a set of predefined standards, a DT is capable of going beyond mere validation to, in fact, challenge these standards based on actual real-life operations. In other words, whereas BIM uses knowledge lying in standards to create and validate models, a DT is capable of using factual data to rather create the knowledge itself.

Table 2: Purposes of the DT Use group 2: ‘Analyze’.

DT Use Purpose	DT Use Purpose definition	Synonyms
02 Analyze	To create new knowledge and provide insights for users and stakeholders about a physical system.	Examine, manage
2.1 Reveal	To uncover, identify and recognize the web of interdependencies, interconnected mechanisms, complex processes, interwoven feedback loops, masked classes, clusters or typologies, hidden trends, patterns and correlations within the physical system.	Learn, mine, recognize, identify, detect, compute
2.2 Simulate	To explore and discover the implications and possible emerging behaviors of a complex web of interacting set of variables.	
2.2.1 Scenario	To find out the implications, impacts or consequences of implementing pre-defined scenarios (akin to non-destructive tests)	What-if, evaluate, assess
2.2.2 Reverse-Test	To identify the scenarios that may lead to failure or breakdown of physical system (akin to destructive tests)	Test, inspect, investigate
2.3 Predict	Concerned with futures studies	
2.3.1 Forecast	to predict the most likely state of a real system in the future, by projecting the known current trends forward over a specified time horizon.	foresee
2.3.2 Back-cast	To question or prove in a prospective manner, how the physical system is operating towards achieving the pre-set aims and goals.	manage, confirm
2.4 Qualitize	Enhance and improve the quality of the outcomes or deliverables produced by an intervention in real world.	
2.4.1 Verify	Verify physical system is performing in line with standards, specifications and best practice.	Validate, check
2.4.2 Improve	Inform the future updating, modifying or enhancing the current standards to be in better coherence and harmony with the actual operational and usage behaviors and patterns.	Update, revise

4.3 Communicate

A fundamental use of DTs is to communicate the information mirrored – via group 1 of DT Uses – and/or analyzed – via group 2 of DT Uses – to various stakeholders according to their interests and the end-goals for which the DT is adopted in the first place. This use allows for information receivers to easier interpret, share and exchange such information in order to facilitate better understanding and decision making. Obviously, this group of uses is normally preceded by or undertaken in parallel with the implementation of the above two groups of DT Uses: mirroring and analysis. This group is divided into 5 purposes: visualize; immerse; document; transform and engage as summarized in table 3.

4.3.1 Visualize

DTs can be used to enhance the exchange and sharing of information through visualization tools and techniques. It helps bringing to the table diverse perspectives, insights and ideas by various stakeholders who are not necessarily familiar with technical languages, codes and algorithms. Such visualizations can be attained using realistic city-scale models, (e.g. city-state of Singapore), walkthroughs, maps and diagrams for geo-visualization

(Anejionu et al. 2019; Boeing, 2019) dashboards, platforms and user-friendly interfaces (Hasegawa et al, 2019).

4.3.2 Immerse

To further complement the communicational means and collaborative environment within which receivers appreciate and interpret the gathered and analyzed data, a DT can enhance real-life perception by virtue of immersive technologies like Virtual Reality [VR], Augmented Reality [AR] and Mixed Reality [MR]. Such novel techniques enable wider participation and involvement and ensure equal levels of understanding among receivers with different social, cultural and language backgrounds. A similar DT Use was carried out in Herrenberg in Germany to develop an immersive environment to display simulations of different traffic planning scenarios in a realistic interactive experience (Dembski, Yamu & Wössner, 2019).

4.3.3 Document

This purpose refers to the export of collected or analyzed data into a standard form for documentation to support undertaking studies, preparing reports, or archiving duties. Unlike the outcomes of visualization and immersion, the products of this use are less comprehensible to ordinary people who are less technically informed or unfamiliar with technical language. Examples may include a Business case developed to justify a proposed strategic intervention or a monthly report for operation and maintenance purposes.

4.3.4 Transform

In this purpose, an eye is kept on the use of DTs at a large scale rather than developing an independent DT for a single asset or organization. This strongly relates to the task of constructing a web of digital twins, or the whole idea of a National Digital Twin as envisaged by cdbb (Hetherington & West, 2020). The primary concern of this DT Use purpose is to allow for any DT to be connected to other DT(s) or at least gets published to be available for use by other parties. For this to be seamlessly accomplished, this DT must be transformed from its original form (i.e. application data model) to be compliant with the one predefined common standard language (i.e. integration data model) – aka Foundation Data Model [FDM] (equivalent to high level core concepts) and Reference Data Library [RDL] (equivalent to sub-classes and vocabularies) – as a part of proper information management.

4.3.5 Engage

A novel use offered by the concept of DT in the realm of city infrastructure and urban planning is people empowerment, civic engagement and allowing for public to participate in the processes of decision and policy making and planning for the cities of the future; their future. As Constantine (2017, p.4) points out, the focus in pursuing this particular purpose of DT Use, “is not on analytical methods to solve problems; rather, it is to enhance substantive participation by a wider range of stakeholders in typical planning strategies of visioning, goal-setting, and value definition”. The new generation of IT has allowed for the realization of such benefits via a myriad of ‘bottom-up’ technological methods and tools including APIs, social media, open-source platforms, Internet of People [IoP], crowd sensing...etc. Example of this are initiatives such as ‘FixMyStreet’ (Gardner & Hespanhol, 2018) or the public involvement, including the participation of marginalized groups (e.g. disabled, elder), in the evaluation of city traffic planning scenarios (Dembski, Yamu & Wössner, 2019). However, at a rather implicit level, citizens may act as sensors to provide public users’ data which can be used to highlight the priorities, usage behaviors and preferences of citizens in order to support the creation of better and favorable solutions to public; this may include self-service electronic checkouts in shopping centers, supermarket loyalty cards and payment data.

Table 3: Purposes of the DT Use group 3: ‘Communicate’.

DT Use Purpose	DT Use Purpose definition	Synonyms
03 Communicate	To exchange collected and analyzed information amongst stakeholders.	interact
3.1 Visualize	To form and vision a realistic representation or model of current or predicted physical system.	review, visioning
3.2 Immerse	To involve interested stakeholders in real-like experiences using immersive technologies such as VR, AR and MR.	involve
3.3 Document	Document and represent gathered and/or analyzed data in a professional	Present

manner and technical language, forms or symbols.			
3.4	Transform	To modify or process information to be received by other DT(s) (e.g. a National DT) or undergo another process	Translate, map
3.5	Engage	To involve citizens and large groups of people including marginalized groups in policy and decision-making processes.	Empower, include

4.4 Control

The control purpose of DT Uses includes the uses in which the data captured from a real system and analyzed is used to control, regulate or actuate that same system. This DT Use explicitly establishes and brings to action the notion of bidirectional communication between physical and virtual systems which underpins the concept of a DT. Table 4 shows the two possible purposes within this group: inform and actuate; while the former displays the ‘passive’ form, the latter is an exemplar of the ‘active’ form of bidirectional communication (Al-Sehrawy & Kumar, 2021). Analogous to this dichotomy is the typology of ‘programmed’ and ‘non-programmed’ types of decisions developed by Simon (1960).

4.4.1 Inform

The vast majority of DT applications in the realm of built environment and city-scale planning end up by enabling this particular DT use purpose. Whether mirroring a real system, analyzing the captured information or communicating the analyses among stakeholders or citizens, all is meant to finally support and inform the interventions back into the real system at focus. This DT use requires human in the loop of the bidirectional communication to interpret the analyzed data and decide or reach a consensus within a collaborative environment on what kind of intervention shall be executed.

4.4.2 Actuate

Actuation is another DT Use purpose that is more relevant to less strategic interventions, like repetitive type of operational and short-term tasks which are better when automated leading to higher productivity and more efficient solutions. Actuation does not necessarily represent a smarter approach when compared to mere ‘informing’, however it is simply more concerned with keeping human out of the loop of the bidirectional communication between the physical and virtual systems.

Table 4: Purposes of the DT Use group 4: ‘Control’.

DT Use Purpose	DT Use Purpose (Definition)	Synonyms
04 Control	To leverage the collected and analyzed information to intervene back into the real world to achieve a desirable state.	Implement, execute
4.1 Inform	To support human operational or strategic decision making, related to future and upcoming interventions in the physical system in real world.	Support, aid
4.2 Actuate	Using CPS and actuators to implement changes to physical system.	Regulate, manipulate, direct, automate, self-govern

5. Conclusion

This study introduced the seed for a Digital Twin Uses Classification System [DTUCS]. This system aims to establish a common standard language and terminology for DT practitioners and researchers within the field of urban planning and city infrastructure management and decision making. This common language enables better sharing of knowledge, exchange of information, and reduces the possibility of miscommunication or misunderstanding. Moreover, DTUCS can heavily support the process of DT procurement as it lays a clear shared background for the DT stakeholders and supply chain to refer to when determining and specifying the exact range of DT Uses required for a certain application. The terminology and vocabulary underpinning DTUCS can contribute to the Reference Data Library [RDL] as a part of the Information Management Framework [IMF] currently being developed to support the National Digital Twin strategy in UK.

The core element of DTUCS upon which different DT uses are specified and distinguished is the purpose of the DT use. It is noticed, though, that some DT use purposes usually precede others (mirroring before analysis; and analysis before control); and some are logically coupled to each other (visualization or immersion linked to engagement). This highlights the interrelated and interconnected nature of relationships between different uses. Accordingly, a proper DT implementation strategy developed to tackle some 'DT application' must consider the full range of available 'DT uses' systemically, with considerable awareness of how the selected uses would complement each other to collectively realize the 'DT benefits' aimed for.

However, and as it could be read from the examples given in the midst of explaining each DT use, it is quite possible for two DT uses to be completely distinct despite having the same DT use purpose, since each is carried out during a different lifecycle stage. In this context, the program lifecycle stage during which a DT use takes place is suggested to be on top of a set of other features that can be utilized to specify a DT use in further detail. Replacing the project view with a program view is primarily concerned with emphasizing the systemic thinking fostered by the concept of DT compared to older schools of thought (i.e. BIM).

Future research will include exploring the other features that can further supplement DTUCS beyond a DT use purpose and the program lifecycle stage, may include, but not limited to: stakeholders; maturity level; level of integration across city layers (e.g.: built environment, infrastructure, natural environment, social systems...etc.); level of integration across organizations and sectors (local and independent DT or cross-sectoral web of DTs); methods and tools used to deliver the DT use purpose; spatial-temporal scales, granularity or resolution.

6. REFERENCES

Al-Sehrawy R., Kumar B. (2021) Digital Twins in Architecture, Engineering, Construction and Operations. A Brief Review and Analysis. In: Toledo Santos E., Scheer S. (eds) *Proceedings of the 18th International Conference on Computing in Civil and Building Engineering. ICCCBE 2020. Lecture Notes in Civil Engineering, vol 98*. Springer, Cham. https://doi.org/10.1007/978-3-030-51295-8_64

Anejionu, O. C., Thakuriah, P. V., McHugh, A., Sun, Y., McArthur, D., Mason, P., & Walpole, R. (2019). Spatial urban data system: A cloud-enabled big data infrastructure for social and economic urban analytics. *Future Generation Computer Systems*, 98, 456-473.

Arup (2019). *Digital Twins. Towards a meaningful framework*. London, UK. Available from: www.arup.com/digitaltwinreport

Bibri, S. E. (2018). *Smart sustainable cities of the future*. Springer Berlin Heidelberg.

Boeing, G. (2019). Spatial information and the legibility of urban form: Big data in urban morphology. *International Journal of Information Management*, 102013.

Constantine, E. K. (2017, April). Urban informatics for social good: definitions, tensions, and challenges. In *Proceedings of the 2nd International Workshop on Science of Smart City Operations and Platforms Engineering*.

Dembski, F., Yamu, C., & Wössner, U. (2019). Digital Twin, Virtual Reality and Space Syntax: Civic engagement and decision support for smart, sustainable cities. In *Proceedings of the 12th International Space Syntax Symposium* (pp. 316.1–316.13). Beijing.

Gardner, N., & Hespanhol, L. (2018). SMLXL: Scaling the smart city, from metropolis to individual. *City, Culture and Society*, 12, 54-61.

Hasegawa, Y., Sekimoto, Y., Seto, T., Fukushima, Y., & Maeda, M. (2019). My City Forecast: Urban planning communication tool for citizen with national open data. *Comput. Environ. Urban Syst*, 77.

Hetherington, J., & West, M. (2020). The pathway towards an Information Management Framework-A 'Commons' for Digital Built Britain.

Kitchin, R. (2014). Big Data, new epistemologies and paradigm shifts. *Big data & society*, 1(1), 2053951714528481.

Kritzinger, W., Karner, M., Traar, G., Henjes, J., & Sihn, W. (2018). Digital Twin in manufacturing: A categorical literature review and classification. *IFAC-PapersOnLine*, 51(11), 1016–1022.

<https://doi.org/10.1016/j.ifacol.2018.08.474>

NIC: National Infrastructure Commission. (2020). Anticipate, react, recover. Resilient infrastructure systems. National Infrastructure Commission.

Rogage, K., Clear, A., Alwan, Z., Lawrence, T., & Kelly, G. (2019). Assessing building performance in residential buildings using BIM and sensor data. *International Journal of Building Pathology and Adaptation*.

Simon, H. A. (1960). *The new science of management decision*.

Theiet: The Institution of Engineering and Technology (2019) Digital twins for the built environment. An introduction to the opportunities, benefits, challenges and risks. Available from: <https://www.theiet.org/impact-society/sectors/built-environment/built-environment-news/digital-twins-for-the-built-environment>

Thiry, M. (2015). *Program management*. Ashgate Publishing, Ltd..

Wan, L., Yang, T., & Parlikad, A. (2019). City-Level Digital Twin Experiment for Exploring the Impacts of Digital Transformation on Journeys to Work in the Cambridge Sub-region. (CDBB_REP_34) <https://doi.org/10.17863/CAM.43317>

Whyte, J., Chen, L., Gamble, C., Genes, C., Pierce, K., Fitzgerald, J., Coca, D., Mayfield, M., Babovic, F., Pedro, A., Shah, N. (2019) *Analysing Systems Interdependencies Using a Digital Twin*, 2018/19 General Project funded by CDBB, Final Report.

Ye, C., Butler, L., Bartek, C., Iangurazov, M., Lu, Q., Gregory, A., Girolami, M. & Middleton, C. (2019). *A Digital Twin of Bridges for Structural Health Monitoring*. In 12th International Workshop on Structural Health Monitoring 2019. Stanford University.

DIGITAL TWIN DRIVEN MUSCULOSKELETAL INJURY PREVENTION SYSTEM

Omobolanle Ogunseiju, Johnson Olayiwola & Abiola Akanmu

Virginia Polytechnic Institute and State University, Virginia, United States.

Chukwuma Nnaji

University of Alabama, Alabama, United States.

ABSTRACT: *The repetitive and physically demanding nature of construction work makes workers vulnerable to work-related musculoskeletal injuries. Performing construction work in awkward postures imposes a significant strain on the body parts and can result in fatigue, injuries, or in severe cases permanent disabilities. One of the effective methods of preventing these injuries is to empower workers with instant information regarding the ergonomic consequences of their working postures so as to enable them control or self-manage the exposures. However, limited tools for identifying and strategically communicating ergonomic risks in actionable formats and work-centric manner has resulted in challenges in achieving this personalized intervention. With digital twin, workers can be dynamically mapped to their virtual replica such that their working postures can be captured, assessed and feedback can be provided via a mixed reality head-mounted display. This study presents a framework for augmenting construction workspaces with digital twin representation of real-time ergonomic exposures of construction workers to facilitate self-management of the risks. The proposed approach obtains posture data using wearable sensors, evaluates the risk factors on body segments, and projects these as a color gradient digital twin overlaid on the gaze points of construction workers. A case study of floor construction work is presented to illustrate the potential of the proposed approach for augmenting digital twin of workers on the gaze point of works. Results highlight the promise of the digital twin system for reducing ergonomic risks during construction work. This paper paves the path for further investigations into opportunities offered by digital twins for improving health and wellbeing of the construction workforce.*

KEYWORDS: *Digital Twin, Ergonomics, Work-related musculoskeletal injuries, Wearable Sensors, Mixed Reality.*

1. INTRODUCTION

The construction industry, being one of the industries with the largest labor force in the United States (8% of the total workforce (BLS, 2018)), continuously struggles with non-fatal injuries associated with musculoskeletal disorders (MSDs). Compared with other industry sectors, the construction industry is about 1.5 times more likely to sustain WMSDs. According to the United States Bureau of Labor Statistics (BLS), 41.2 out of every 10,000 full time employed workers suffer from WMSDs resulting in 12 days away from work ((BLS), 2018). The long-term effects of MSDs include pain, fatigue, and in severe cases, permanent disability. This obstinate health problem also comes with a high economic price. In the United States, direct workers' compensation costs due to WMSDs amount to \$20 billion annually, and up to five times that much for indirect costs related to replacing workers ((OSHA), 2014). In addition, ample evidence indicates that WMSDs lead to premature departures from the workforce (BLS, 2019, Progress, 2008, Umer et al., 2016, Village and Ostry, 2010). Construction workers perform simple manual labor to more specialized tasks such as roofing, masonry, and carpentry. These tasks are physically demanding and repetitive, requiring workers to assume static non-neutral or awkward postures, thus overexerting the body segments. Overexertion for prolonged period results mostly in soreness and pains, and sprains, strains, and tears.

Existing efforts to prevent overexertion have been largely focused on the following: (1) training workers to make them aware of safe and unsafe postures for performing work; (2) the use of external wearables such as exoskeletons, to reduce physical demands of construction tasks and; (3) tracking workers' performance and alerting them to unsafe postures. For example, the traditional approach to training workers involves using manuals developed by safety and health organizations such as Occupational Safety and Health Administration (OSHA) and National Institute for Occupational Safety and Health (NIOSH) (Moore et al., 2011, Albers and Estill, 2007) to educate workers on how to identify ergonomic problems, find and implement the solutions to potentially reduce the risk of injury (Albers and Estill, 2007, Safety, 2010). Akanmu et al. (2020) developed a flexible training environment based on virtual reality where workers can practice work and build their motor skills in performing work in safe behavior. Training with the manuals and within the virtual training environment occurs before or after workers' actual work task, thus the linkage between the actual performance of the worker and learning for continuous improvement is not established. Exoskeletons are external wearables designed to boost the strength and endurance

of workers or alert workers of risks of unsafe postures. There is limited evidence regarding the extent to which these wearables can reduce physical demands of construction work (Kim et al., 2019). Yan et al. (2017) and (Yan et al., 2018) assessed a wearable inertial measurement units-based personal protective equipment for alerting workers about the risk associated with the trunk of rebar workers. Although the feedback was provided as alarms, workers have limited information about the type and extent of the ergonomic risk – this is critical for making corrective actions.

One way to prevent overexertion is by providing workers with instant and personalized feedback to make them self-aware of the ergonomic exposures associated with their performance (Wang et al., 2015, Cheng et al., 2012, Chaffin et al., 1986, Yan et al., 2017). The nature of the feedback can be a significant factor in motivating workers to self-manage their exposures (Ouellet and Vézina, 2014, Ratzon and Jarus, 2009, Faucett et al., 2002). Advances in motion capture technologies such as Inertial Measurement Units (IMUs) enables measurement of body movements and postures. These measurements could be leveraged for real-time posture analysis and assessment, prediction of potential health risks, and developing recommendations for self-correcting working postures. This knowledge can be mapped to the virtual replica of a worker to create a bijective relationship so that updates in the worker's performance can be mirrored or constantly synchronized to the virtual replica – this information-rich virtual representation is termed digital twin. Presenting this digital twin in real-time via an augmented reality head-mounted display will enable workers to understand the type of exposure and possible corrections to control their working posture. With the digital twin, there is a seamless connection and continuous data and information exchange between workers and their virtual replica.

This paper seeks to describe a digital twin driven approach to improving worker health and wellbeing through real-time two-way mapping between construction workers and their digital representation. To enhance understanding of the potential of digital twin in construction, this study focuses on the development and application of the digital twin approach in delivering personalized information that can improve worker's self-awareness and management of WMSDs. The paper presents a system architecture, which integrates the key enabling technologies needed to facilitate the digital twin approach. Application of the digital twin approach to wooden floor construction work is presented to illustrate the potential benefits of two-way mapping between workers and their digital representation.

1.1 Digital Twin

The concept of digital twin was initially informally introduced in 2002 by Michael Grieves, during one of his course lectures on product lifecycle management. Grieves formalized the concept in 2017 in a white paper where he defined the concept as a set of virtual information constructs that are designed to fully describe a potential or an existing physical product (Grieves and Vickers, 2017). In recent years, digital twin has been applied to three key domains: aviation, manufacturing, and healthcare. For example, Mandolla et al. (2019) integrated digital twin and 3D printing for securing and monitoring data during the production of aircraft components. In the manufacturing industry, Zhuang et al. (2018) proposed a digital-twin based production supervision for product assembly shop-floors. According to the authors, smart manufacturing was enabled through real-time data acquisition of the assembly shop-floors which provided the link between the physical assembly shop-floors and its digital representation. Similarly, digital twin has gained substantial recognition in healthcare. Martinez-Velazquez et al. (2019) introduced the concept of cardio digital twin for detecting Ischemic Heart Disease conditions. Liu et al. (2019) proposed a digital twin simulation for personal healthcare management in adults which was implemented through medical wearable devices. In the construction industry, few studies have proposed the implementation of digital twins in construction processes. For example, Yusen et al. (2018) proffered a digital twin approach to managing the life cycle of a capital-intensive project. The analytical and intelligent contents of the developed digital twin were facilitated through internet of things and big data. However, with the implementation of digital twins in the healthcare domain, and its potentials in the construction industry, have faced complexities involved in designing the digital representation of its corresponding physical counterpart – this has limited the applications of digital twin in these industries.

1.2 Research Gap

Recently, there has been a transition from traditional healthcare delivery to a more patient-centered care. The rapid evolution of computational technologies such as internet of things (IoT) and big data has instigated the adoption of personalized healthcare for patients. The Institute of Medicine (Baker, 2001) defines patient-centered care as personalized care in response to individual patient's needs and experience. Chatterjee et al. (2017) demonstrated that by assessing and analyzing patient's medical history, precise personalized treatment plans can be prescribed for the patients. Chen and Snyder (2013) stated that personalized healthcare enables the possibility for patients to

be treated based on their molecular structure. Chen and Snyder (2013) further posit that personalized healthcare has the potentials of transforming the healthcare system from symptoms-oriented disease treatment to prevention and early diagnosis of diseases. Personalized care has been proven to be effective when patients or beneficiaries adopt a practice-based approach to monitoring their health conditions such as through the utilization of self-tracking/management health devices (Sharon, 2017). Self-management promises longer life expectancy, patient comfort, and higher medical precision when patients are equipped with the appropriate experiential knowledge and competencies to deal with their health conditions (Sharon, 2017). Despite the aforementioned opportunities offered by patient-centered care, there have been limited efforts towards the design of personalized environments that can empower individual construction workers with critical information needed to self-manage their ergonomic exposures. With the potentials of digital twin for real-time monitoring of construction workers (Kan and Anumba, 2019), this study presents the development of an automated system for assessing ergonomic exposures of construction workers and suggesting corrective actions.

2. RESEARCH OBJECTIVE AND CONTRIBUTION

The main objective of this study is to develop and test an automated system that continuously monitors the kinematics of workers' body segments, assesses the ergonomic exposures of body-segments of workers and delivers immediate feedback by augmenting the risk associated with the body segments as a digital twin on the gaze point of construction workers. The main contribution of this research is to propose a digital twin system that tracks workers' working postures and communicates the ergonomic risks in an actionable format via an augmented virtual replica within the field of view of the worker. This study also contributes to mixed reality and sensing technology literature by integrating kinematic data with digital body models to improve health and wellbeing of the construction workforce.

3. METHODOLOGY

Fig. 1 shows the key steps employed in conducting this study. A comprehensive review of literature on the concept of digital twins was conducted to identify the distinct definitions and key elements of digital twins, and understand how the concept has been applied in other industry sectors. The digital twin employs wearable sensor data with a mixed reality head-mounted display to augment the risks associated with the body-segments in the form of a replica of the user on the work surface or gaze of the user. The augmented virtual replica is intended to inform users about the extent of the risk associated with their motions and postures so that they can self-manage their exposures. The digital twin system was tested in a laboratory environment to elucidate how the augmented replica would be displayed to a user engaged in carpentry work.

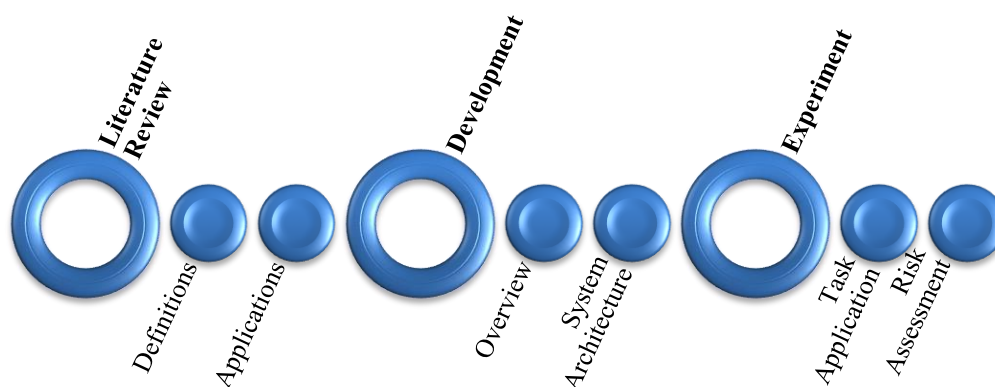


Fig. 1: Overview of research methodology

4. DIGITAL TWIN MUSCULOSKELETAL INJURY PREVENTION SYSTEM

4.1 Overview

Digital twin is gaining increasing interest for their potentials and perceived impact in other industry sectors, such

as healthcare, manufacturing, and aviation. The term has been defined in literature in the following ways:

- Digital twin is a reflection of two-way dynamic mapping of physical objects and their virtual replica (Tao and Zhang, 2017).
- Digital twins are computer-based models that simulate and mirror physical entities, which may be humans, objects, or processes (Barricelli et al., 2019).
- Digital twins are precise cyber or virtual replicas of physical systems that represent all of their functionalities (Alam and El Saddik, 2017).
- Digital twins are virtual models of physical systems, objects, or processes that are created in digital worlds to simulate and monitor their performance in real environments (Mabkhot et al., 2018).

Based on these definitions, for a system to function as a digital twin, there needs to be a synergy or two-way mapping between physical systems and their virtual replica or digital representation. In the context of this research, a digital twin is taken to mean a virtual representation of a construction worker with the potential of understanding changes in the status of the worker through data sensing, to analyze, assess and predict ergonomic and other health risks. The two-way dynamic mapping ensures that changes in a worker's action and virtual representation are automatically reflected in each other. Fig. 2 illustrates the basic framework of the digital twin system, in which, the virtual avatar is mapped to the physical worker through the exchange of data and information. In general, the digital twin consists of three key elements: (1) the physical worker, (2) their digital twin such as virtual model or avatar, and (3) the information that flows between the physical worker and the digital twin. Based on these key elements, sensed motion of the workers is transmitted to their virtual representation to complete the simulation, validation, and dynamic adjustment. The simulation data are fed back to the workers to enable them respond to the changes and improve their performance.

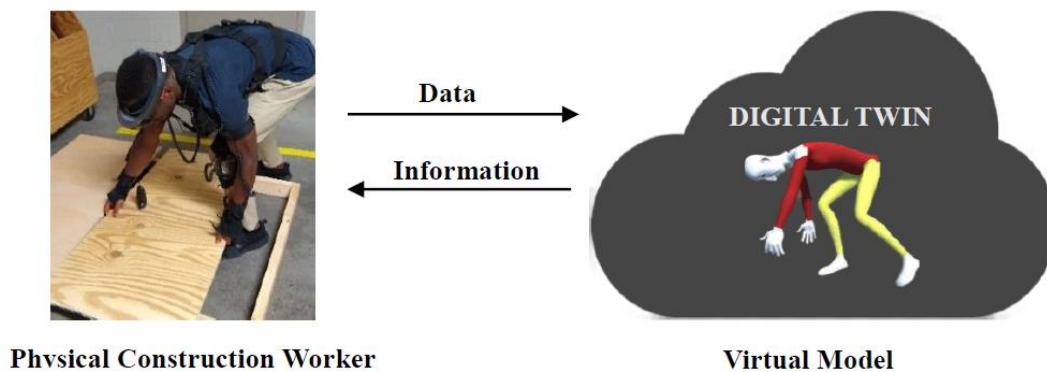


Fig. 2: Digital twin concept – adaptation of Grieves' model (Grieves and Vickers, 2017).

4.2 System Architecture of Digital Twin

Fig. 3 illustrates a system architecture of the digital twin. The six-tier architecture consists of a sensing tier, data tier, communication tier, computation tier, application tier, and action tier. The system architecture of the digital twin helps identify the key enabling technologies and their role in assessing the working postures of construction workers and providing feedback on the risk associated with the body-segments. Each tier is described as follows:

4.2.1 Sensing tier

The sensing tier consists of sensing systems for capturing the movements of body segments of workers, the physiological condition of the workers, and the environmental conditions of the work area. These sensing systems include wearable sensors (e.g., IMU), vision-based sensors (e.g. cameras) and physiological sensors (e.g., heart rate monitors, and galvanic skin response sensors) for measuring worker's postures, physical workloads, and stress levels. The IMUs consist of 3-axial accelerometer, gyroscope, and magnetometer sensors.

4.2.2 Data tier

The data tier contains the data types generated by the sensing tier, such as raw acceleration and angular velocity, temperature, and humidity. This tier may also comprise videos of construction workers while performing work, type of construction work and resources, location and nature of work area, and other characteristics that may influence the risk factors of WMSDs.

4.2.3 Communication tier

The communication tier contains different types of communication protocols, e.g. local and wireless communication protocols such as WLAN, Wi-Fi, and Bluetooth. These protocols serve the purpose of transferring (1) the sensed data (i.e. raw acceleration and angular velocity) from the data tier to the database in the storage tier and (2) extracted knowledge from the computation tier to an augmented reality head-mounted display in the action tier. The protocols also transfer the knowledge to the storage tier.

4.2.4 Storage tier

The storage tier contains the local database and database server. This stores the sensed data for exchange and sharing with other tiers. The storage tier is constantly updated with the sensed data transferred by the communication tier. The sensed data are stored for use in the computation tier and as the historical performance of workers. These historical information can be extracted and mined for comparing the performance of workers with target benchmarks.

4.2.5 Computation tier

The computation tier contains artificial intelligence (e.g., pattern recognition, unsupervised/supervised learning, and statistical techniques) and posture evaluation techniques (e.g., Ovako Working Posture Analysis System (OWAS), Postural Ergonomic Risk Assessment (PERA) and Rapid Entire Body Assessment (REBA)). Within this tier, artificial intelligence algorithms are employed for detecting changes and identifying important patterns and trends e.g., for recognizing tasks involved in construction activities from sensed data. The sensed data for each task are converted to angles and holding times of body segments using the posture evaluation techniques. Work posture of the user, for example, the angles of a bent of trunk flexion (shown in Table 1) and maximum holding times (Delleman and Dul, 2007), will be used as criteria evaluating the level of physical exposure and associated WMSD risk.

4.2.6 Action tier

The action tier includes the AR HMD and virtual replica of the user-developed using Unity gaming engine. The risk level data for each body segment from the computation tier is represented in the virtual replica as color codes (e.g., green, yellow, and red, representing no and low risk, medium risk, and high risk, respectively). Other safety and health-related actionable information or recommendation can also be represented in this format. In this way, the user understands the level of risk and corrective actions. As the user performs work, the digital twin of the user reflects the risk associated with each of the body segments. The AR HMD used in this study is the Microsoft HoloLens. With the HoloLens, the digital twin of the user appears as a hologram on the gaze point of the user.

Table 1: PERA Risk classification chart (in degrees).

Body Segment	No Risk	Low Risk	Medium Risk	High Risk
Trunk Flexion		0 – 20	21 – 60	>60
Trunk Lateral Flexion			0 – 10	>10
Shoulder Flexion		0 – 20	21 – 60	>60
Elbow Flexion		0 – 20	21 – 60	>60
Hip Flexion	0 – 30	31 – 60	61 – 90	>90

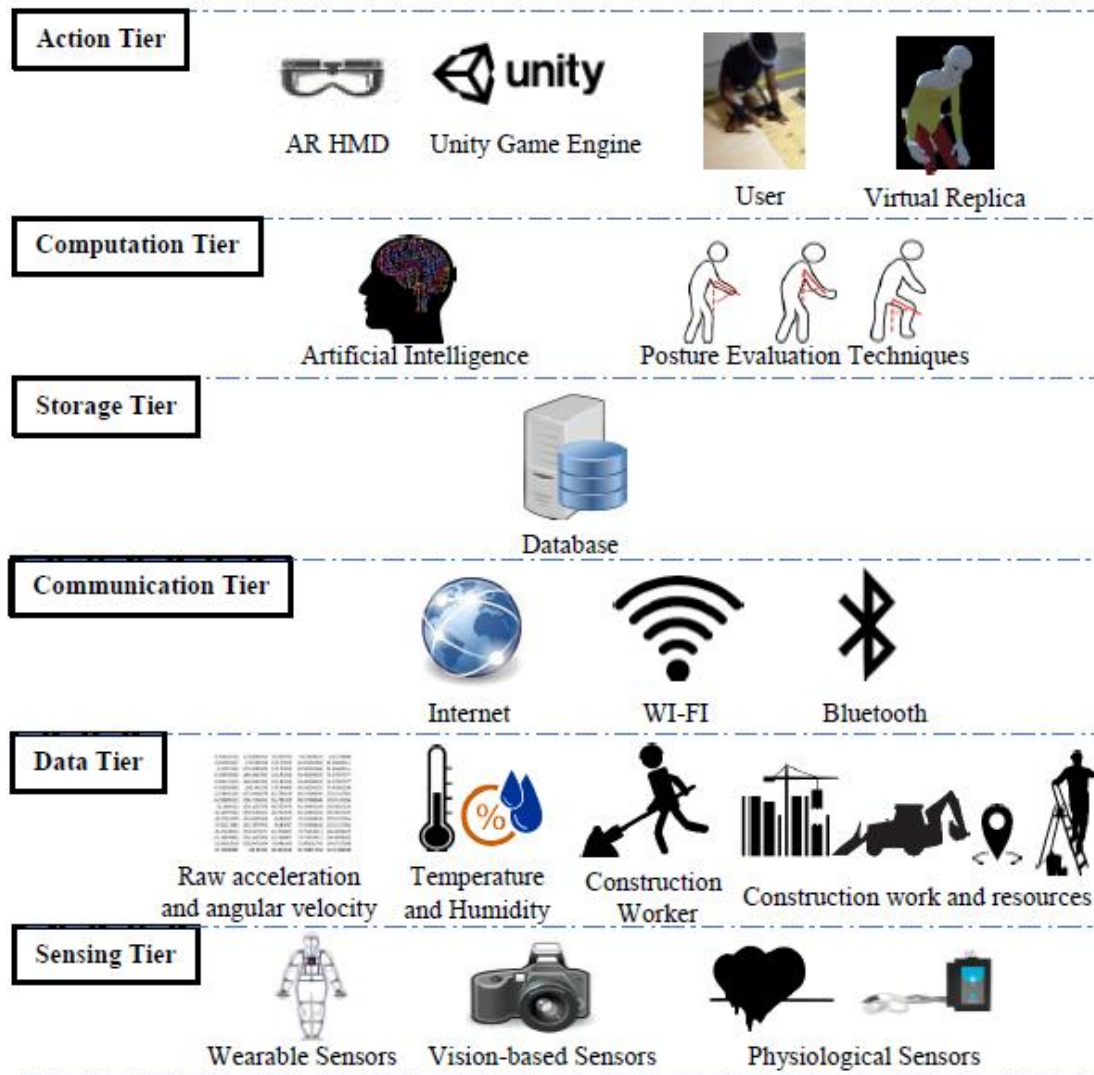


Fig. 3: System architecture of digital twin.

5. EXPERIMENT AND RESULTS

According to the United States Bureau of Labor Statistics (BLS), carpenters are about 2.5 times more likely to sustain WMSDs (61.1 MSDs per 10,000 full time employed workers) than the general construction trades, with an average of 9 days away from work (BLS, 2019). Carpenters work on floors, walls, and ceilings, in tasks that include framing, drywalls, and finishing. As they undertake flooring tasks, they repeatedly assume awkward postures including bend their back, twisting, kneeling, and squatting. As a result, they often experience disorders such as sprains, strains and tears, soreness and pains, carpal tunnel syndrome, and tendonitis. The trunk is the most affected body segment. The digital twin musculoskeletal prevention system described in Section 3 was applied to a simulated wooden floor construction work consisting of seven tasks completed in two cycles. The tasks and durations are shown in Table 2.

Before commencing the flooring work, the participant wore the PrioVR wearable sensors and the HoloLens. Each of the IMU units was adjusted to match the body segment being tracked. The wearable sensor provided time-stamped acceleration, angular rotation, and rotation data for each body segment at a frequency of 100 Hz, i.e, 100 data points per second. The activity was recorded for 42 minutes.

Table 2: Floor framing tasks, duration, and data points for Cycle 1 and 2

Tasks	Cycle 1		Cycle 2	
	<i>Duration (seconds)</i>	<i>Data Points</i>	<i>Duration (seconds)</i>	<i>Data Points</i>
T1 Inspecting workplace	34	340	9	90
T2 Align board	30	303	15	153
T3 Displacing board	4	42	6	60
T4 Measuring and mapping out vent location	240	2864	340	3393
T5 Cutting out vent location on board	254	2535	238	2392
T6 Place board	47	470	12	117
T7 Nailing board in place	389	3882	632	6305

The risks associated with the trunk flexion for each task are shown in Fig. 4. The task ‘Place board – T6’ for cycles 1 and 2 involves placing wooden boards and takes place in less than 50 secs. Fig. 5 shows the posture assumed by the participants and the level of risk associated with the trunk. The color gradient of the digital twin informs the participant of the risk so that he can assume ‘squatting’ posture as recommended by the ergonomic procedures of lifting loads to reduce back injury (Albers and Estill, 2007). ‘Cutting out vent location on board – T5’ and ‘Nailing board in place – T7’ tasks require the most holding times and highest ‘high’ risk to the trunk. The digital twin of the participant that reflects the extent of the risk of the assumed posture for task T7 is shown in Fig. 6.

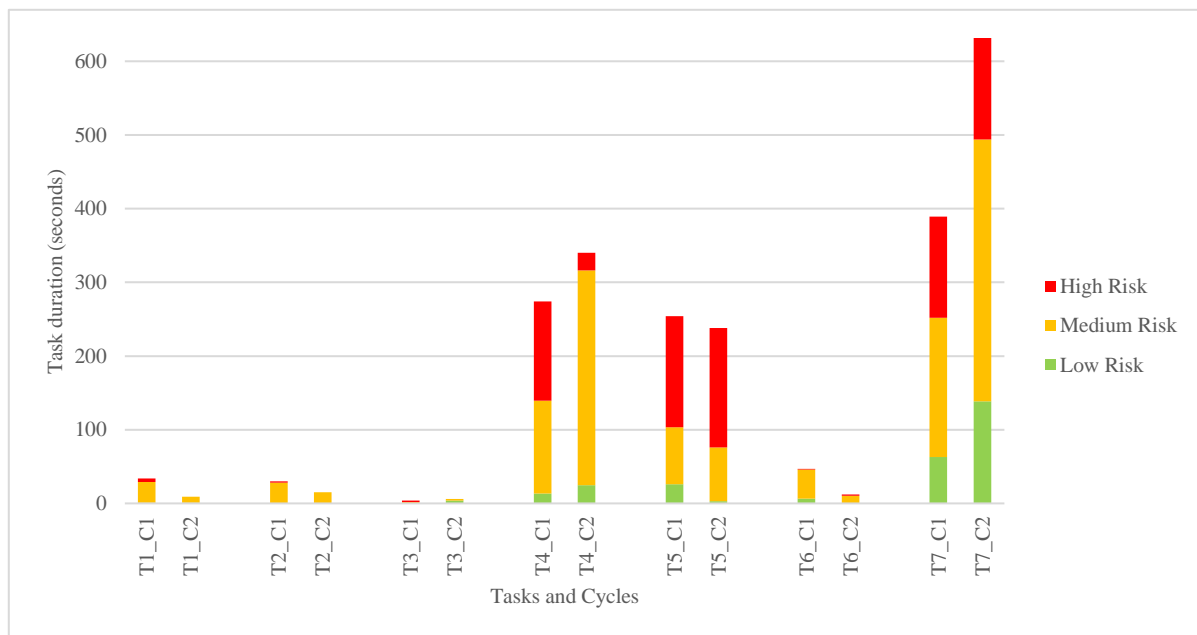


Fig. 4: Trunk flexion for carpentry tasks, cycles and risks.



Fig. 5: Place board task (T6) (left) and digital twin (right).

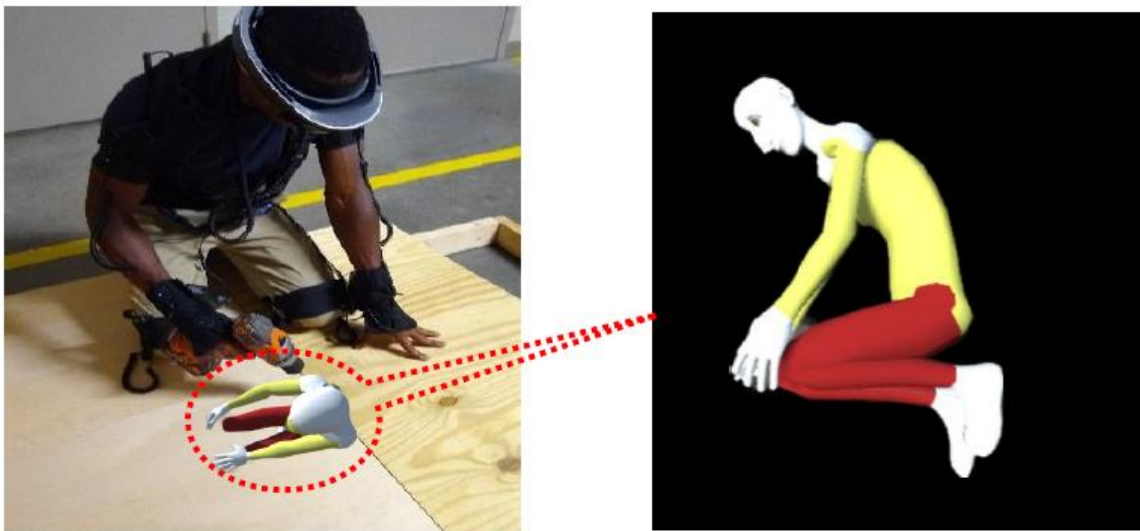


Fig. 6: Nailing board in place task (T7) (left) and digital twin (right).

6. DISCUSSION

Self-management has been considered as a way of reducing the triggers of health conditions (Costa et al., 2015, Panagioti et al., 2014). The effectiveness of this approach is hinged on patients' access to information about the nature and extent of their health condition (Levin-Zamir and Peterburg, 2001, Chiauzzi et al., 2015). A significant body of literature suggests providing patients with this information while they are involved in the activity or event triggering the exposure (Yan et al., 2017, Yan et al., 2018, King et al., 2012, Van Der Kriek et al., 2014). However, except for few existing studies like that of Yan et al., 2018, Yan et al., 2017 and Akanmu et al., 2020, there have been limited efforts towards the design of interventions for equipping workers with actionable information on how exposures of work-related musculoskeletal injuries could be self-managed.

The developed digital twin system can be considered as a shift towards converting sensed kinematic data into actionable information for use in physical environments via mixed reality. The actionable information obtained via the digital twin system is augmented on the workspace of workers to inform them about the extent of the risk associated with their performance. The presentation of real-time information in actionable format typically understood by humans makes the present study a deviation from the current trend observed in literature. Application of the digital twin to carpentry work is significant owing to the prevalence of trunk disorders amongst these trades. The preliminary findings of this study indicate opportunities and promise of the digital twin system in reducing risk factors of WMSDs. For example, the effect of the digital twin system could be noticed in cycle 2 of tasks T4 and T7 in Fig. 4, which are commonly known to pose risk to carpenters (Gilkey et al., 2007), where the participant corrected his posture based on the digital twin augmented on his workspace. This supports the findings that people are self-motivated to change when presented with information relating to the risks associated with their actions (Seguin et al., 1999, Wang et al., 2019). It is possible that continuous use of the digital twin system could trigger further reduction in the risk associated with the performance of the tasks (Kartchava and Nassaji, 2019).

Some of the limitations of the developed digital twin system include the following: the use of the laboratory scale wearable sensor could restrict movement as such is not feasible for field deployment. There is a need for an investigation into the use of isolated sensing and communication systems that can be integrated into personal protective equipment safety gear. The augmented information currently produced by the digital twin system is based on the real-time risks associated with the body parts. Incorporating suggested movements or postures could improve the rate of compliance of the workers as less time will be spent on figuring out next steps to reduce the exposures.

7. CONCLUSIONS AND FUTURE WORK

This paper proposes a digital twin system for improving workers' awareness of the ergonomic risks associated with their working postures so that they can take corrective actions. The system integrates workers and their virtual replica using sensed movement data obtained from motion capture devices and posture assessment data obtained using posture evaluation techniques. The assessment data is embedded in the virtual replica to reflect the risks associated with body segments of each posture. Construction workers can view their virtual replica as a digital twin augmented on their gaze point as a hologram using a HoloLens. A six-tiered system architecture comprising of sensing, data, communication, computation, application, and action tiers was developed. This architecture integrates the key technologies for sensing, communication, computation, and action together to realize the cognitive two-way dynamic mapping between construction workers and their virtual replica. To demonstrate the functionality of the architecture, the digital twin system was applied to a laboratory simulated wooden floor construction activity. Future work will involve (but not limited to) the following:

- Improving the developed digital twin system to utilize less invasive sensing systems, such as smaller sized IMUs and video cameras. This will facilitate the deployment of the digital twin system on construction sites;
- Investigating the characteristics or affordances of the digital twin and other complementary information significant for educating construction workers about the risks associated with their postures;
- Performing field studies to quantifying effectiveness of the digital twin augmented on workers' gaze point on their work behavior and health;
- Exploring applications of the digital twin to preventing other work-related hazards for different construction trades; and
- Collaborating with medical practitioners to addressing health-related issues not considered in this study to further improve the development of the digital twin system.

8. REFERENCES

- BLS, (2018). *Nonfatal Occupational Injuries and Illnesses Requiring Days Away from Work* [Online]. Available: <https://data.bls.gov/PDQWeb/cs> [Accessed June 12, 2020].
- OSHA, (2014). *Prevention of Work-related musculoskeletal disorders* [Online]. Available: https://www.osha.gov/pls/oshaweb/owadisp.show_document?p_id=4481&p_table=UNIFIED_AGENDA [Accessed June 12, 2020].

- Akanmu, A. A., Olayiwola, J., Ogunsejju, O. & Mcefeters, D. (2020). Cyber-physical postural training system for construction workers, *Automation in Construction*, Vol. 117, 103272.
- Alam, K. M. & El Saddik, A. (2017). C2PS: A digital twin architecture reference model for the cloud-based cyber-physical systems, *IEEE access*, Vol. 5, 2050-2062.
- Albers, J. & Estill, C. F. (2007). Simple solutions. *Ergonomics for construction workers. DHHS (NIOSH) publication*, (2007-122).
- Baker, A. (2001). *Crossing the quality chasm: a new health system for the 21st century*, British Medical Journal Publishing Group.
- Barricelli, B. R., Casiraghi, E. & Fogli, D. (2019). A Survey on Digital Twin: Definitions, Characteristics, Applications, and Design Implications, *IEEE Access*, Vol.7, 167653-167671.
- BLS, (2019). *Nonfatal Occupational Injuries and Illnesses Requiring Days Away from Work* [Online]. Available: <https://www.bls.gov/news.release/pdf/osh2.pdf> [Accessed June 18, 2020].
- Chaffin, D. B., Galloway, L. S., Woolley, C. B. & Kuciemba, S. R. (1986). An evaluation of the effect of a training program on worker lifting postures, *International Journal of Industrial Ergonomics*, Vol. 1 No.2, 127-136.
- Chatterjee, P., Cymbarknop, L. J. & Armentano, R. L. (2017). IoT-based decision support system for intelligent healthcare—applied to cardiovascular diseases, *Proceedings of the 7th International Conference on Communication Systems and Network Technologies (CSNT)*, Nagpur, India, 362-366.
- Chen, R. & Snyder, M. (2013). Promise of personalized omics to precision medicine, *Wiley Interdisciplinary Reviews: Systems Biology and Medicine*, Vol. 5, No. 1, 73-82.
- Cheng, T., Migliaccio, G. C., Teizer, J. & Gatti, U. C. (2012). Data fusion of real-time location sensing and physiological status monitoring for ergonomics analysis of construction workers, *Journal of Computing in Civil engineering*, Vol. 27, No.3, 320-335.
- Chiauzzi, E., Rodarte, C. & Dasmahapatra, P. (2015). Patient-centered activity monitoring in the self-management of chronic health conditions, *BMC medicine*, Vol.13, No. 1, 1-6.
- Costa, E., Giardini, A., Savin, M., Menditto, E., Lehane, E., Laosa, O., Pecorelli, S., Monaco, A. & Marengoni, A. (2015). Interventional tools to improve medication adherence: review of literature, *Patient preference and adherence*, Vol. 9, 1303.
- Delleman, N. & Dul, J. (2007). International standards on working postures and movements, *Ergonomics*, Vol. 50, No. 11, 1809-1819.
- Faucett, J., Garry, M., Nadler, D. & Ettare, D. (2002). A test of two training interventions to prevent work-related musculoskeletal disorders of the upper extremity, *Applied ergonomics*, Vol. 33, No. 4, 337-347.
- Gilkey, D. P., Keefe, T. J., Bigelow, P. L., Herron, R. E., Duvall, K., Hautaluoma, J. E., Rosecrance, J. S., Sesek, R. (2007). Low back pain among residential carpenters: ergonomic evaluation using OWAS and 2D compression estimation, *International Journal of Occupational Safety and Ergonomics*, Vol. 13, No. 3, 305-321.
- Grieves, M. & Vickers, J. (2017). Digital twin: Mitigating unpredictable, undesirable emergent behavior in complex systems. In *Transdisciplinary perspectives on complex systems* (85-113). Springer, Cham.
- Kan, C. & Anumba, C. (2019). Digital twins as the next phase of cyber-physical systems in construction. *Computing in civil engineering 2019: Data, sensing, and analytics* (256-264). Reston, VA: American Society of Civil Engineers.
- Kartchava, E. & Nassaji, H., (2019). The role of task repetition and learner self-assessment in technology-mediated task performance, *ITL-International Journal of Applied Linguistics*, Vol. 170, No. 2, 180-203.
- Kim, S., Moore, A., Srinivasan, D., Akanmu, A., Barr, A., Harris-adamson, C., Rempel, D. M. & Nussbaum, M. A. (2019). Potential of exoskeleton technologies to enhance safety, health, and performance in construction: Industry perspectives and future research directions, *IISE Transactions on Occupational Ergonomics and Human*

Factors, Vol. 7, No. 3-4, 185-191.

King, D. K., Toobert, D. J., Portz, J. D., Strycker, L. A., Doty, A., Martin, C., Boggs, J. M., Faber, A. J., Geno, C. R. & Glasgow, R. E. (2012). What patients want: relevant health information technology for diabetes self-management, *Health and Technology*, Vol. 2, No. 3, 147-157.

Levin-Zamir, D. & Peterburg, Y. (2001). Health literacy in health systems: perspectives on patient self-management in Israel. *Health promotion international*, Vol. 16, No. 1, 87-94.

Liu, Y., Zhang, L., Yang, Y., Zhou, L., Ren, L., Wang, F., Liu, R., Pang, Z. & Deen, M. J. (2019). A novel cloud-based framework for the elderly healthcare services using digital twin, *IEEE Access*, Vol. 7, 49088-49101.

Mabkhot, M. M., Al-ahmari, A. M., Salah, B. & Alkhalefah, H. (2018). Requirements of the smart factory system: a survey and perspective, *Machines*, Vol. 6, No.2, 23.

Mandolla, C., Petruzzelli, A. M., Percoco, G. & Urbinati, A. (2019). Building a digital twin for additive manufacturing through the exploitation of blockchain: A case analysis of the aircraft industry, *Computers in industry*, Vol. 109, 134-152.

Martinez-velazquez, R., Gamez, R. & El Saddik, A. (2019). Cardio Twin: A Digital Twin of the human heart running on the edge., *IEEE International Symposium on Medical Measurements and Applications (MeMeA), 2019. IEEE*, Istanbul, Turkey, 1-6.

Moore, S. M., Steiner, L. J. & Torma-krajewski, J. (2011). Practical demonstrations of ergonomic principles.

Ouellet, S. & Vézina, N. (2014). Work training and MSDs prevention: Contribution of ergonomics, *International journal of Industrial ergonomics*, Vol. 44, No.1, 24-31.

Panagioti, M., Richardson, G., Small, N., Murray, E., Rogers, A., Kennedy, A., Newman, S. & Bower, P. (2014). Self-management support interventions to reduce health care utilization without compromising outcomes: a systematic review and meta-analysis, *BMC health services research*, Vol. 14, No.1, 356.

Progress, R. (2008). Identification and Management of Musculoskeletal Disorders in the Roofing Industry. Illinois.

Ratzon, N. Z. & Jarus, T. (2009). Prevention of Workers' Musculoskeletal Disorders Musculoskeletal Disorders: A Four-Stage Model. *International Handbook of Occupational Therapy Interventions*. Springer.

Safety, O. (2010). Health Administration (OSHA), Strain, sprain, and material handling safety tips for employers. *Website: www.workzone.safety.org/.../strain_sprain*, 3.

Seguin, C., Pelletier, L. G. & Hunsley, J., (1999). Predicting Environmental Behaviors: The Influence of Self-Determined Motivation and Information About Perceived Environmental Health Risks 1, *Journal of Applied Social Psychology*, Vol. 29, No. 8, 582-1604.

Sharon, T. (2017). Self-tracking for health and the quantified self: Re-articulating autonomy, solidarity, and authenticity in an age of personalized healthcare, *Philosophy & Technology*, Vol.30, No.1, 93-121.

Tao, F. & Zhang, M. (2017). Digital twin shop-floor: a new shop-floor paradigm towards smart manufacturing. *Ieee Access*, Vol. 5, 20418-20427.

Umer, W., Li, H., Szeto, G. P. Y. & Wong, A. Y. L. (2016). Identification of biomechanical risk factors for the development of lower-back disorders during manual rebar tying, *Journal of Construction Engineering and Management*, Vol. 143, No. 1, 04016080.

Van Der Krieke, L., Wunderink, L., Emerencia, A. C., De Jonge, P. & Sytema, S. (2014). E-mental health self-management for psychotic disorders: State of the art and future perspectives, *Psychiatric Services*, Vol. 65, No.1, 33-49.

Village, J. & Ostry, A. (2010). Assessing attitudes, beliefs and readiness for musculoskeletal injury prevention in the construction industry, *Applied ergonomics*, Vol. 41, No. 6, 771-778.

Wang, D., Dai, F. & Ning, X. (2015). Risk assessment of work-related musculoskeletal disorders in construction: state-of-the-art review, *Journal of Construction Engineering and management*, Vol. 141, No. 6, 04015008.

Wang, J., Liu-Lastres, B., Ritchie, B. W. & Mills, D. J. (2019). Travellers' self-protections against health risks: An application of the full Protection Motivation Theory, *Annals of Tourism Research*, Vol. 78, 102743.

Yan, X., Li, H., Li, A. R. & Zhang, H. (2017). Wearable IMU-based real-time motion warning system for construction workers' musculoskeletal disorders prevention, *Automation in Construction*, Vol. 74, 2-11.

Yan, X., Li, H., Zhang, H. & Rose, T. M. (2018). Personalized method for self-management of trunk postural ergonomic hazards in construction rebar ironwork, *Advanced Engineering Informatics*, Vol. 37, 31-41.

Yusen, X., Bondaletova, N., Kovalev, V. & Komrakov, A. (2018). Digital twin concept in managing industrial capital construction projects life cycle, *Proceedings of Eleventh International Conference "Management of large-scale system development" (MLSD, 2018. IEEE, Moscow, Russia, 1-3.*

Zhuang, C., Liu, J. & Xiong, H. (2018). Digital twin-based smart production management and control framework for the complex product assembly shop-floor, *The International Journal of Advanced Manufacturing Technology*, Vol. 96, No. 1-4, 1149-1163.

HOLOGRAPHIC LEARNING ENVIRONMENT FOR BRIDGING THE TECHNICAL SKILL GAP OF THE FUTURE SMART CONSTRUCTION ENGINEERING STUDENTS

Omobolanle Ogunseiju, Abiola Akanmu, and Diana Bairaktarova
Virginia Polytechnic and State University, Virginia, United States

ABSTRACT: *The growth in the adoption of sensing technologies in the construction industry has triggered the need for graduating construction engineering students equipped with the necessary skills for deploying the technologies. One obstacle to equipping students with these skills is the limited opportunities for hands-on learning experiences on construction sites. Inspired by opportunities offered by mixed reality, this paper presents the development of a holographic learning environment that can afford learners an experiential opportunity to acquire competencies for implementing sensing systems on construction projects. The interactive holographic learning environment is built upon the notions of competence-based and constructivist learning. The learning contents of the holographic learning environment are driven by characteristics of technical competencies identified from the results of an online survey, and content analysis of industry case studies. This paper presents a competency characteristics model depicting the key sensing technologies, applications and resources needed to facilitate the design of the holographic learning environment. A demonstrative scenario of the application of a virtual laser scanner for measuring volume of stockpiles is utilized to showcase the potential of the learning environment. A taxonomic model of the operational characteristics of the virtual laser scanner represented within the holographic learning environment is also presented. This paper contributes to the body of knowledge by advancing immersive experiential learning discourses previously confined by technology. It opens a new avenue for both researchers and practitioners to further investigate the opportunities offered by mixed reality for future workforce development.*

KEYWORDS: *Mixed Reality; Sensors; Education; Workforce; Holographic*

1. INTRODUCTION

Uncertainties arising from the complex nature of construction projects have necessitated the need for investing in sensing technologies to improve situation awareness of project teams. Some construction companies are currently utilizing vision and component-based sensing systems such as laser scanners, Radio Frequency Identification (RFID), and Global Positioning System (GPS) for resource tracking (Miller, 2008), safety (Beatty, 2016), productivity (Skanska, 2009) and quality management (Turner, 2016, Skanska, 2009). Miller (2008) reported using passive RFID tags to track precast concrete seats from fabrication to installation during a stadium construction project. Implementation of the RFID tags resulted in a reduction of the project schedule by 10 days and cost savings of one million dollars. Turner (2016) reported deploying GPS for locating existing utilities on an infrastructure project. This resulted in minimal retrofitting of the new utilities and consequently reduced labor and material costs.

Considerable efforts have also been made by researchers: Laser scanners and drones/Unmanned Aerial Vehicles (UAV) have been investigated for capturing as-built data to create 3D models of facilities (Huber et al., 2010, Turkan et al., 2012). RFID, GPS, and ultra-wideband systems have been explored for material, and equipment tracking on the jobsite (Ko, 2010). According to Jang and Skibniewski (2009), tracking construction materials with RFID systems can yield up to a 64% reduction in labor costs over two years. Similarly, the potentials of proximity sensing technologies for improving safety on the jobsite have been explored (Hallowell et al., 2010, Marks and Teizer, 2012). For example, proximity sensors have been used for enhancing situation awareness by tracking workers' proximity to moving equipment (Oloufa et al., 2003, Choe et al., 2013), and automated construction vehicle navigation (Lu et al., 2007). Despite the efficacy and increasing deployment of these technologies, the construction industry is experiencing a shortfall of graduating construction engineering students and existing workforce equipped with the necessary skills to implement the technologies on construction projects (Hannon, 2007, Kapliński, 2018). This opinion was also shared by Zhang and Lu (2008) who posited that students are unaware of the potentials of sensing technologies in the construction industry.

For construction engineering students to acquire technical skills for implementing sensing technologies, it is pertinent to engage them in hands-on learning with the technologies. However, inaccessibility to construction sites for experiential learning and in some cases, high upfront costs of acquiring sensing technologies are encumbrances to equipping construction engineering students with the required technical skills. One way to reduce these barriers is by augmenting digital 3D representations of construction sites and sensing technologies in the form of an interactive

holographic scene (HS), a concept of mixed reality, into the physical classroom so that students can explore the technicalities involved in deploying sensing technologies on construction projects. With an interactive holographic learning environment, students can access different difficult situations that are too dangerous to access on real construction sites. The use of the term ‘holographic’ is meant to refer to augmented reality that appears to users as 3D objects existing in the physical world as popularized by Microsoft.

1.1 Theoretical Underpinning

The development of the holographic learning environment is grounded in competencies-based and constructivist learning theories. Competencies based theory involves connecting classroom learning with activities in the workplace for an accurate representation of the workplace and an easier transition of students into the workforce (Gonczi, 1999). This study supports this theory by identifying and incorporating the required competencies for deploying sensing technologies in the construction industry, in the holographic learning environment. While engaged in the holographic learning environment, students can interact with the jobsite characteristics, explore tasks, identify risks, and select appropriate sensing technology for mitigating the risks. Consequently, they can construct their knowledge of the diverse construction contexts for the application of sensing technologies. This also supports the notion of the constructivist learning theory which posits that students develop knowledge of a particular topic by being actively engaged in a social learning environment (Bada and Olusegun, 2015).

1.2 Mixed Reality Learning Environment

The emergence of digital learning environments such as virtual reality (VR) and Mixed Reality (MR) has spurred a prolific interest amongst researchers and educationists owing to its ability to experientially engage students in a social learning environment. The application of VR environments to enhance education has been embraced in medicine (Liu, 2014), construction (Messner et al., 2003), and industrial (Maffei and Onori, 2019) engineering programs. According to (Pantelidis, 2010), VR leverages on visualization techniques for enhancing the comprehension of abstract classroom concepts. However, the immersive feature of VR environments restricts self-localization of participants in the virtual and real-world (Psotka, 1995). All senses of participants are actively engaged in the virtual environment hence, participants may struggle to simultaneously maintain their position in the virtual and real world. Azhar et al. (2018) who introduced VR for teaching design communication reported that students immersed in a VR learning environment can become motion sick and unstable and often require more supervision from instructors. Contrary to VR, MR merges the real and virtual environment (Fig. 1), by superimposing virtual objects into the real world or integrating real-world objects into a virtual environment (Pan et al., 2006). In this way, students are consciously aware of the real world while engaged in the virtual learning environment. Through active engagement in the learning process, MR has been proven to improve students’ learning of spatial structure, and long-term retention of what is taught in the environment (Radu, 2014). MR learning environment affords students a hazard-free sharable virtual learning environment that can accommodate multiple learners (Pan et al., 2006). Furthermore, Azhar et al. (2018) who reported the efficacy of MR in improving design communication skills in construction education, concluded that MR was more effective for educating construction students about design plans when compared to traditional design reading processes. The study further revealed the potentials of MR for supporting hands-on learning in the classrooms. Therefore, this study employed MR for equipping construction engineering students with hands-on learning experience.

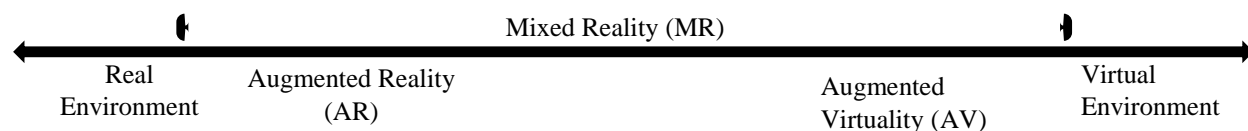


Fig. 1: Reality-Virtuality Continuum (Milgram and Kishino, 1994).

1.3 Research Objectives and Contribution

This study introduces an MR learning environment in the form of HS for bridging the technical skill gap of construction engineering students in deploying sensing technologies on construction projects. To develop the learning environment, the required competencies for implementing sensing technologies on construction projects were identified through a survey of industry practitioners and online case studies of industry applications. The study also explored the extent to which the sensing technologies are taught in construction engineering programs by surveying faculties across the United States (US). The results from the surveys and case studies provided the required

competencies for deploying sensing technologies on construction projects. Based on these competencies, the learning contents of the HS were identified. This paper elucidates preliminary findings from the surveys and case studies, and a description of the HS. Implications of the findings and the interactive learning environment for bridging the technical skill gap in the construction industry are also discussed.

2. METHODOLOGY

To develop the interactive HS, the research methodology illustrated in Fig. 2 was adopted. To provide evidence to support the need for the study, construction engineering instructors in institutions in the US were surveyed to capture the extent to which sensing technology-related contents are being taught. To identify the required competencies and learning content for the HS environment, an online survey of industry practitioners was conducted. The survey data were analyzed using cluster analysis and descriptive tools such as averages, and percentages. The study further performed content analysis of the industry case studies on the applications of sensing technologies. To extract the required competencies from the survey results and case studies, a mind mapping of identified applications of sensing technologies was conducted using a readily available mind mapping application. The sensing technologies and applications were modeled in the HS environment in the form of virtual objects using Unity game engine. Specific learning contents were guided by a general set of characteristics identified from the competencies and a taxonomic model of the operational characteristics of sensing technologies.

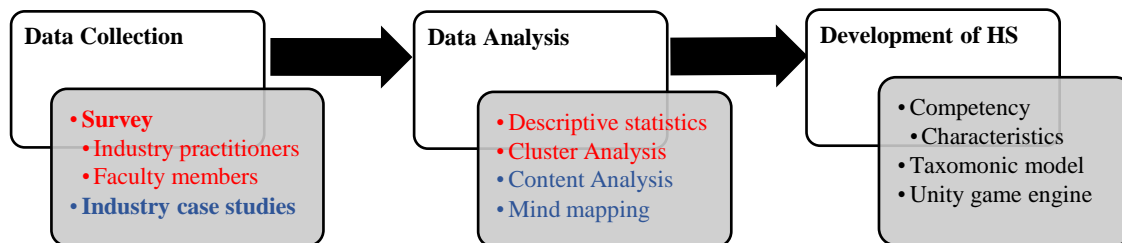


Fig. 2: Research methodology.

2.1 Data Collection

2.1.1 Survey

A total of 73 industry practitioners from 46 construction companies in the US were surveyed to obtain their perceptions on sensing technologies in the industry. The online survey included closed-ended questions regarding the types of sensing technologies currently deployed by construction companies, the current level of adoption of the sensing technologies, future sensing needs of construction companies, and skills required of the future construction engineering workforce to implement the sensing technologies on projects. The survey also included open-ended questions on the specific current and future construction applications of sensing technologies. Responses from the survey provided detailed information on the competencies and learning objectives for the HS. Further details on the characteristics of the respondent's companies are provided in Table 1.

Table 1: Company size of industry participants

Company size based on number of employees	Number
10- 50 employees	9
50 - 100 employees	4
100-500 employees	14
More than 500 employees	15

The study also surveyed a total of 37 faculty members across the US to understand the state of sensing technologies in construction engineering education. Generally, the faculty members were surveyed to obtain data on the percentage of institutions currently teaching sensing technologies curriculum. Close-ended questions were asked to obtain data on the extent to which sensing technologies are being taught in these institutions.

2.1.2 Industry case studies

To acquire a rich set of applications of sensing technologies in the construction industry, online construction industry case studies were reviewed. This involved surveying and documenting cases where different sensing technologies have been implemented on construction projects. A general survey of case studies on construction companies' websites was first conducted. This yielded a total of 17 case studies of laser scanners, drones, RFIDs, and ground-penetrating radar, and GPS from different companies. Thereafter, a thorough web search using "Laser scanner case studies in construction companies" search string was used. "Laser scanner" was then replaced in the search string with each sensing technology. The search was further filtered by omitting search results without the exact words "Sensing technologies", and "construction". Search results from marketers and developers of sensing technologies providers were excluded from this study. The web search produced 14 case studies for only laser scanners. Consequently, a total of 31 industry case studies were considered in this study. Construction applications from these case studies were analyzed for identifying the characteristics of the HS learning environment.

2.2 Data Analysis

Survey data on the types of sensing technologies currently deployed by construction industries, the current level of adoption of the sensing technologies, future sensing needs of construction companies, and skills required of the future construction engineering workforce to implement the sensing technologies on projects were analyzed using descriptive tools. Open-ended questions on different construction applications of sensing technologies were analyzed to categorize similar construction applications/activities for each sensing technology using cluster analysis. Similarly, content analysis of identified industry case studies of construction applications of sensing technologies was conducted. The contents of each case study were classified based on the case study title, sensing technology adopted, specific construction activities, meta description of the activity, identified benefits of the sensing technology, and appropriate website links to the case study. Similar construction activities from the survey and industry case study analysis of each sensing technology were grouped using mind mapping. Fig. 2 illustrates an example of mind mapping of construction applications of laser scanners.

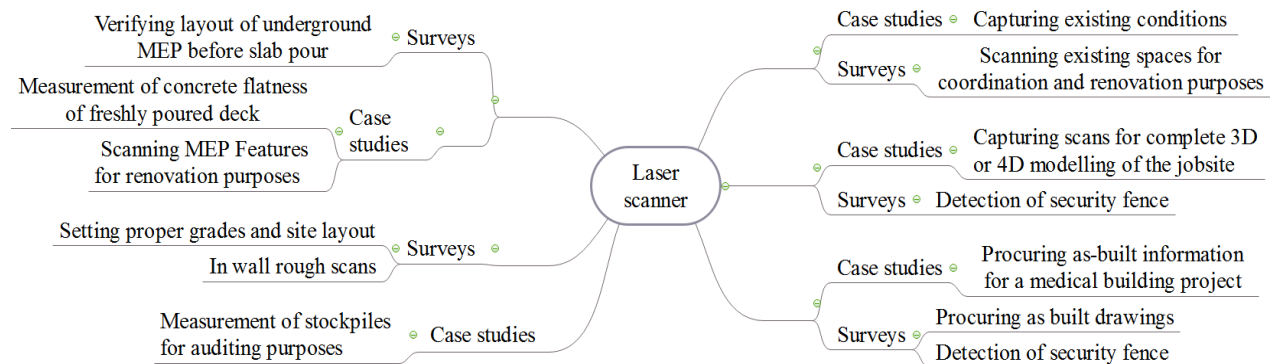


Fig. 2: Mind mapping of laser scanning construction applications.

2.3 Development of Holographic Scene Learning Environment

To develop the interactive learning environment, the characteristics of the HS need to include learning outcomes such as the required skills, knowledge, and abilities for deploying sensing technologies in the industry. These characteristics were categorized into two: (1) the jobsite characteristics which are the identified construction applications of each sensing technology; and (2) the operational characteristics of each sensing technology. To represent key construction applications of each sensing technology in the HS, a set of characteristics (Fig. 3) was developed to guide the process. The characteristics entail the construction applications to be represented, the performance metrics of each construction application, and the resources for executing the applications in the HS. As illustrated in (Fig. 3), construction applications of each sensing technology were classified into performance metrics in the construction industry such as productivity, safety, schedule, and quality control (Hughes et al., 2004, Battikha, 2003). These construction applications were further delineated into the required resources (avatar, materials, and equipment) for representing

them in the HS. For example, the jobsite consists of construction materials like stockpiles, 2 partially completed buildings, rebars, and woodpiles. Avatars were used for representing different construction trades like painters, carpenters, and construction craft laborers. Also, construction vehicles such as dump trucks, tower crane, bulldozers were represented as equipment in the holographic scene. Furthermore, to represent the operational characteristics of each sensing technology, a taxonomic model entailing the hierarchal development of each sensing technology was used to guide the development process of the sensing technologies as game objects in the HS. Fig. 4 shows an example of a taxonomic model for the development of the laser scanner in the HS.



Fig. 3: Set of characteristics needed by the HS learning environment.

The HS was developed using Unity game engine. As shown in the system architecture of the HS in Fig. 5, the HS consists of game objects, MR toolkit (MRTK), and services. The game objects in the learning environment entail the

digital representations of the jobsite characteristics and the virtual sensing technologies. Each game object in this scene consists of components that provide the functionalities and essence of each game object. The components of each game object are the mesh collider, transform component, and mobile game objects like avatars. The construction vehicles had animators as an additional component for defining their movements in the HS. Each game objects in the HS have scripts attached to them. The scripts are written in C# programming language in visual studio and allows responses to inputs from the students, and also control the coordination of the learning environment. The MRTK in the HS creates the interactivity when students are immersed in the holographic environment using the Microsoft HoloLens. The MRTK consists of scripts, spatial awareness, camera, gaze, hand, and cursor. This enables the usability of the learning environment in an MR environment using the HoloLens. For example, spatial awareness provides the geometry of the holographic scene and instigates an interaction between the holographic scene and the real world. While the gaze and cursor enable the students to focus on any game object by placing it in the center holographic scene. The Microsoft HoloLens only allows for the selection of objects through hand gestures such as air-tapping. To access the learning environment, the application is loaded into the HoloLens, and students can open the application and interact with it directly. The services enhance the user experience when using HoloLens (Akanmu and Olayiwola, 2019). As the students interact with the learning environment, their interactions are related to a first-person avatar.

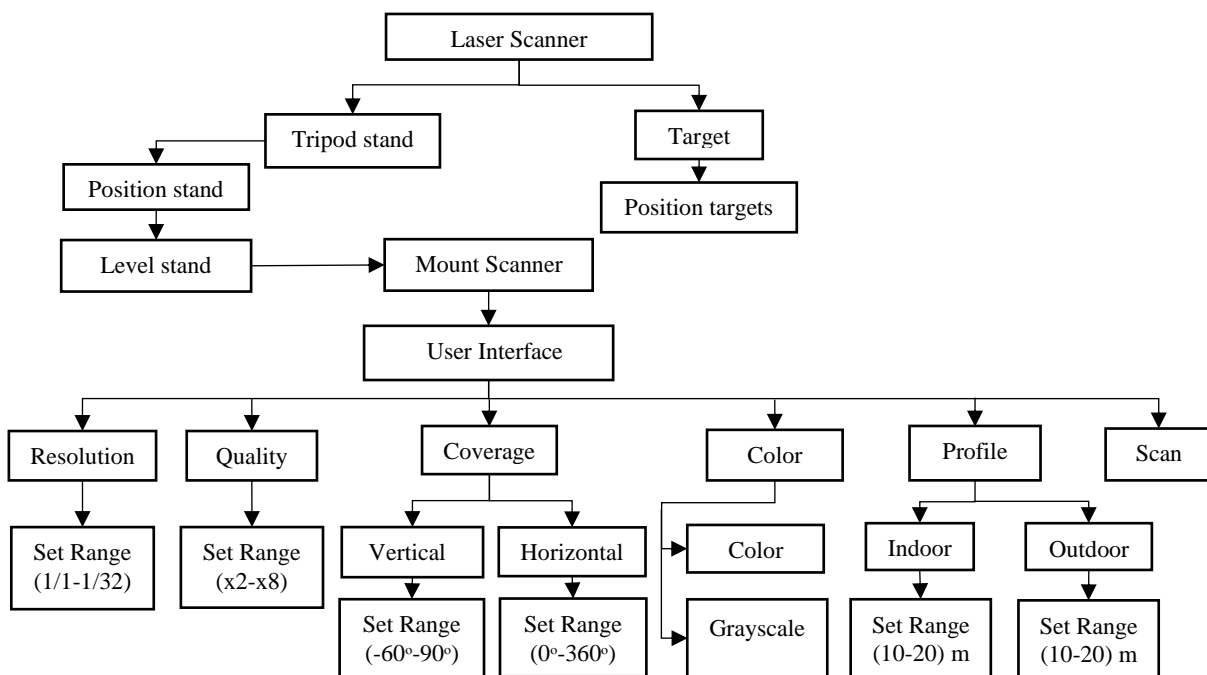


Fig. 4: Taxonomy of operation of virtual laser scanners in the HS.

3. RESULTS

This section presents the preliminary results of this study. Firstly, the results of the online survey of industry practitioners and construction faculty members were presented. The number of industry case studies of construction applications of each sensing technologies was also represented in this section. The developed holographic scene with an example of stockpile measurement using laser scanner was further elucidated in this section.

3.1 Survey Results

3.1.1 Industry practitioners

Preliminary survey results from the construction industry indicated a high rate of adoption of sensing technologies. 80% of the surveyed construction companies have started adopting sensing technologies while 20% are yet to adopt sensing technologies on their projects (Fig. 6). Fig. 7 revealed the rate of adoption of each sensing technology in the industry with cameras and laser scanners, GPS, RFID, and drones being the most frequently adopted on construction projects.

Respondents from the construction industry were asked to suggest sensing technologies to be included in construction engineering education. Fig. 8 shows the sensing technologies suggested by industry practitioners for inclusion in construction engineering education. Over 90% of the respondents suggested that laser scanner should be included in construction engineering education. The top 5 suggested and frequently adopted sensing technologies were represented in the HS.

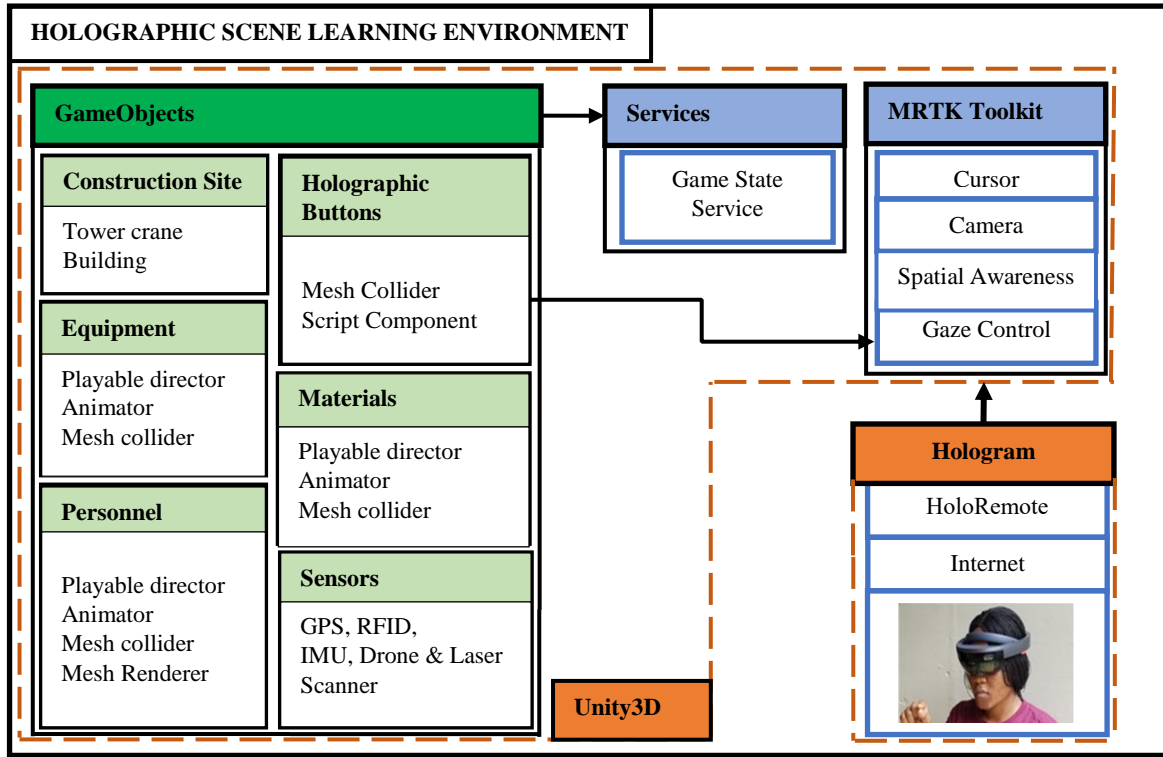


Fig. 5: System architecture of the holographic learning environment (Akanmu and Olayiwola, 2019).

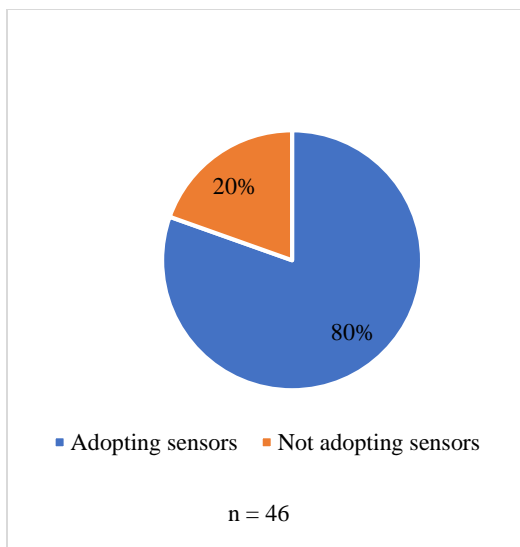


Fig. 6: Level of adoption of sensing technologies.

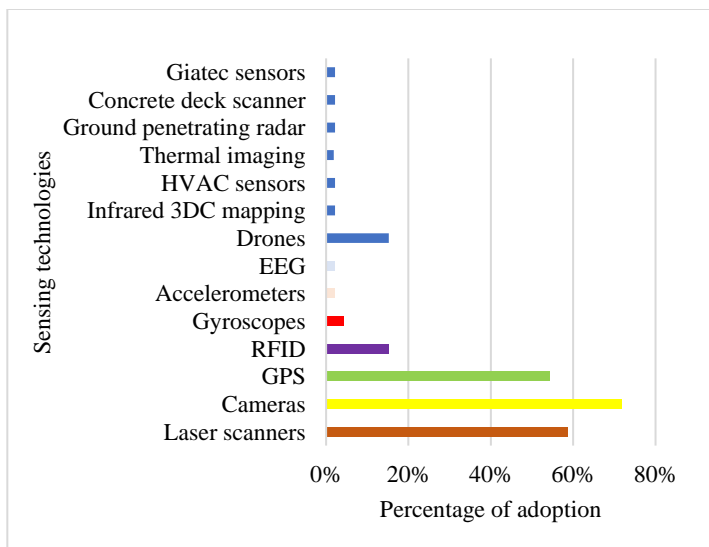


Fig. 7: Adoption rate of each sensing technologies.

3.1.2 Faculty members

Instructors from different institutions across the US were surveyed to explore the extent to which sensing technologies are currently taught in construction engineering education. Fig. 9 shows that 54% of the respondents have started teaching sensing technologies while 46% are yet to include sensing technologies in their curriculum. Fig. 10 reveals the percentages of institutions already teaching each sensing technologies in construction education. Similar to the high adoption rate of laser scanner in the industry (Fig. 7), most faculty members have started including laser scanners in their curriculum.

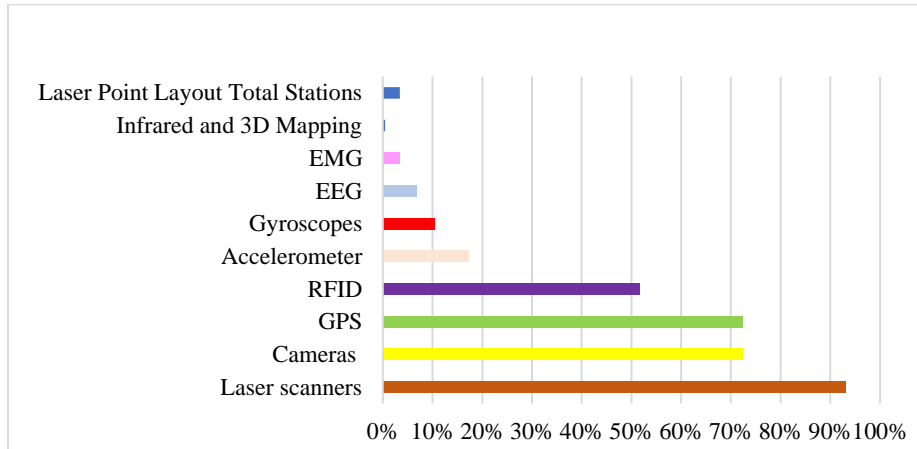


Fig. 8: Suggestions for the inclusion of sensing technologies in construction education.

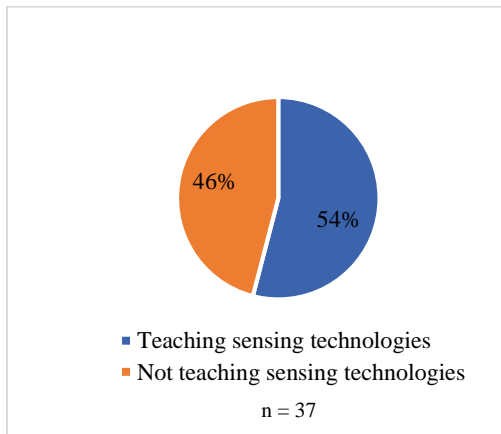


Fig. 9: Extent of teaching sensing technologies.

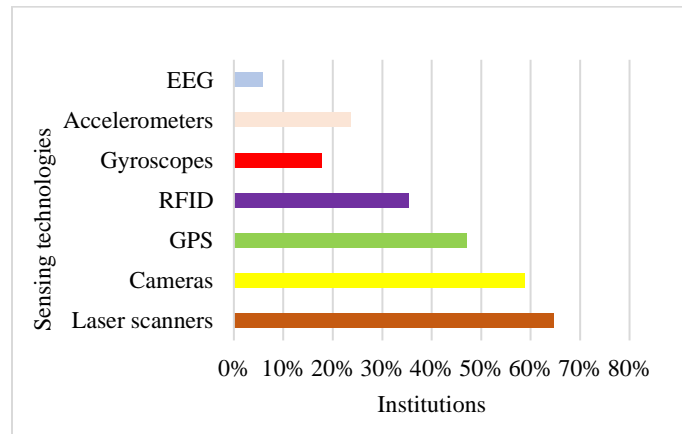


Fig. 10: Institutions teaching sensing technology.

3.2 Industry Case Studies

Preliminary results from the content analysis of the industry case studies on construction applications of sensing technologies showed that laser scanner has been widely used on construction projects. As depicted in Fig. 11, 18 case studies of laser scanner were retrieved. The construction applications of laser scanners extracted from the case studies include the following: measurement of the volume of metal piles; layout of existing mechanical, electrical, and plumbing systems; measuring existing conditions of buildings for renovation purposes; conducting site layout; and generating as-built models of construction projects.

3.3 Example Scenario of Stockpile Measurement using Laser Scanner

The HS aims to provide an interactive environment where students can digitally explore different construction activities and sensing technologies used in the construction industry. As depicted in Fig. 12, the HS allows students to investigate jobsite characteristics i.e. the tasks, operations, and dependencies. Students are also able to explore the

context for use of each sensing technology to address risks of construction projects. For example, to measure the volume of a stockpile in the HS, students were able to explore the stockpile on the jobsite and other surrounding activities. Students will need to decide on the possibility of utilizing the laser scanner or any other sensing technologies for the stockpile measurement. The selection of laser scanner for the stockpile measurement will guide the students in understanding the operations of a laser scanner. By clicking the laser scanner button, the laser scanner accessories such as tripod stand, scanner, targets, and scanner interface will appear on the user interface.

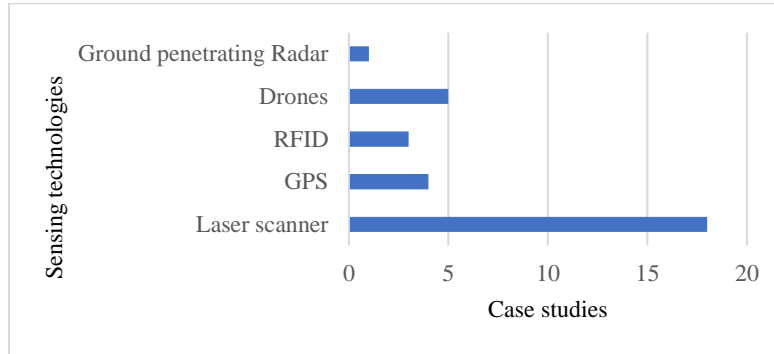


Fig. 11: Sensing technologies identified from the industry case studies

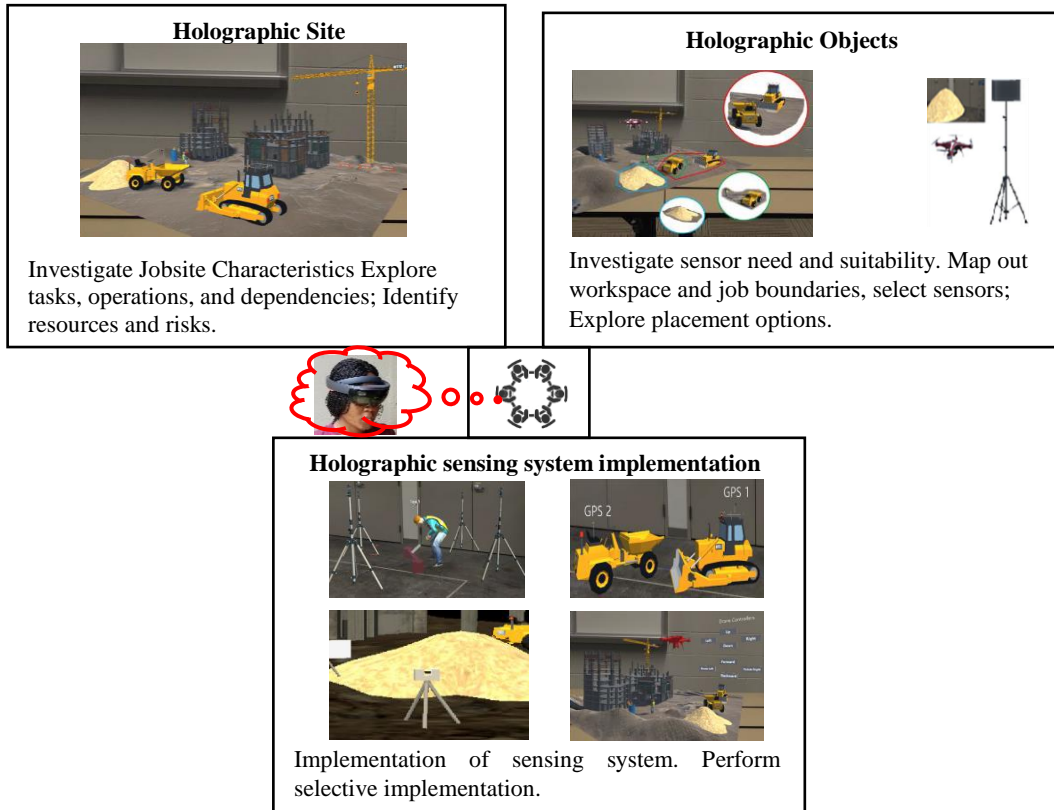


Fig. 12: Example of the HS learning environment (Akanmu and Olayiwola, 2019)

As illustrated in Fig. 13a, students will be required to position the tripod of the laser scanner. Students can decide on the most suitable location to place the laser scanner. This is an important step as the placement decision influences the coverage of the laser scanner and the number of scans captured.

On selecting the scanner button from the menus on the interface, the scanner appears on the tripod stand. The students can also select and position the targets around the stockpile (Fig. 13b) which has similar consequences as the

positioning of the tripod. After positioning the targets, students can interact with the scanner interface. As depicted in Fig. 13c, the interface of the laser scanner allows students to select the coverage, resolution, quality, color, and profile of the scans, which engages their decision-making skills. Students will be propelled to engage all the settings displayed on the scanner interface. This is achieved by deactivating the scan button until all settings on the scanner interface have been engaged (Fig. 13d). This process will educate the students on how resolution and quality can affect time taken to scan the stockpile. The higher the resolution and quality of the scan, the more the time required to scan the stockpile. On the selection of the scan button, the laser scanner will commence scanning the stockpile. After the scanning process has been completed, students will have the option of viewing the scans, and saving or discarding the completed scans. If the scans are saved, the students can close the HS learning environment and view their scans via the HoloLens.

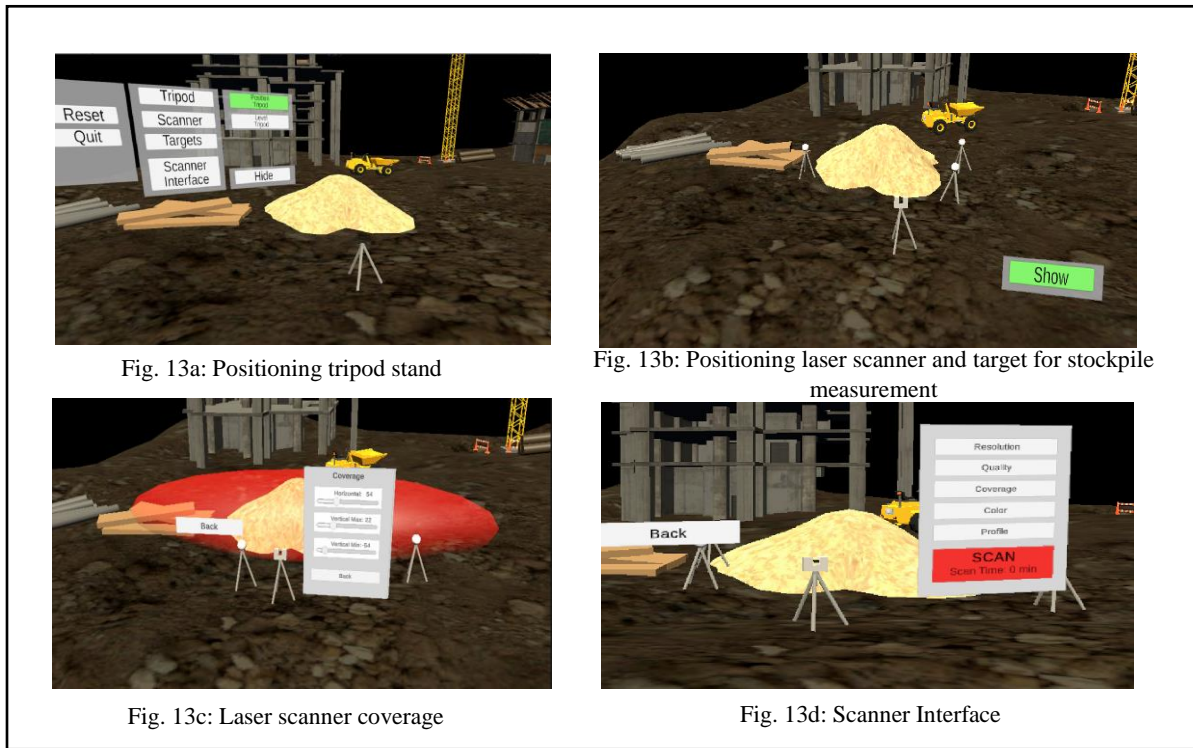


Fig. 13: Implementation of laser scanner in the HS learning environment.

4. CONCLUSIONS AND FUTURE WORKS

The need for timely and efficient completion of construction projects has resulted in a growing rate of adoption of sensing technologies in the construction industry. This in turn has triggered the need for future construction workforce with the necessary technical skills for deploying sensing technologies on construction projects. This paper presents the development of a flexible and captivating learning environment that affords learners an experiential opportunity to acquire sensing systems application knowledge and improve their risk-identification abilities. As a first step, this study surveyed construction engineering instructors to assess the extent to which sensing technology related contents are being taught in institutions. The study also surveyed industry practitioners to capture the required skills for deploying sensing technologies on construction projects and applications that would also benefit from the technologies. Results from the online survey revealed a gap between the technical skill needs of the construction industry and the offerings of construction engineering programs. Industry case studies were also analyzed to further enrich these skills. Based on the established skills and potential tasks and activities, a general set of characteristics was identified and leveraged for developing the interactive HS learning environment. Within the environment, students can explore the digitally represented activities, and associated risks and resources. Students can also explore the suitability of each sensing system for mitigating the risks of the activities. An example of how volumes of stockpile can be measured with the laser scanner within the learning environment is described. Future work will involve the following:

- Conducting cognitive walkthrough evaluation of the HS learning environment with construction industry practitioners to assess its learnability;
- Conducting usability studies with students to identify characteristics of the HS learning environment that facilitate problem solving with sensing technologies;
- Conducting a comparative analysis of student groups to investigate the potential of virtual sensors within the HS learning environment to enhance addressing construction problems.

5. ACKNOWLEDGEMENT

This material is based upon work supported by the National Science Foundation (Award #: IUSE – 1916521). Any opinions, findings, and conclusions or recommendations expressed in this material are those of the authors and do not necessarily reflect the views of the NSF.

6. REFERENCES

Akanmu, A. & Olayiwola, J. (2019). Interactive Holographic Scenes for Teaching Wireless Sensing in Construction Engineering and Management. *Proceedings of CIB (International Council for Research and Innovation in Building and Construction) W78 conference*, Northumbria University Newcastle, 926-934.

Azhar, S., Kim, J. & Salman, A. (2018). Implementing Virtual Reality and Mixed Reality Technologies in Construction Education: Students' Perceptions and Lessons Learned. *Proceedings of ICERI2018 Conference*, Seville, Spain, 3720-3730.

Bada, S. O. & Olusegun, S. (2015). Constructivism learning theory: A paradigm for teaching and learning. *Journal of Research & Method in Education*, Vol. 5, No. 6, 66-70.

Battikha, M. G. (2003). Quality management practice in highway construction. *International Journal of Quality & Reliability Management*, Vol. 20 No. 5, 532-550.

Beatty, B. (2016). *Balfour Beatty Awarded \$196 Million North Block at Capitol Crossing Contract*. Available: [https://www.balfourbeattyus.com/our-company/media/press-releases/balfour-beatty-awarded-\\$196-million-north-block-at](https://www.balfourbeattyus.com/our-company/media/press-releases/balfour-beatty-awarded-$196-million-north-block-at) [June, 2020].

Choe, S., Leite, F., Seedah, D. & Caldas, C. (2013). Application of sensing technology in the prevention of backing accidents in construction work zones. *Proceedings of ASCE International Workshop on Computing in Civil Engineering*, Los Angeles, California, 557-564.

Gonczi, A. (1999). 12 Competency-based learning. *Understanding learning at work*, p.180

Hallowell, M. R., Teizer, J. & Blaney, W. (2010). Application of sensing technology to safety management. *Proceedings of Construction Research Congress: Innovation for Reshaping Construction Practice*, Banff, Alberta, Canada, 31-40.

Hannon, J. J. (2007). Emerging Technologies for Construction Delivery. NCHRP Synthesis 372. National Cooperative Highway Research Program. *Transportation Research Board, Washington, DC*.

Huber, D., Akinci, B., Tang, P., Adan, A., Okorn, B. & Xiong, X. (2010). Using laser scanners for modeling and analysis in architecture, engineering, and construction. *Proceedings of 44th Annual Conference on Information Sciences and Systems (CISS)*. IEEE, Princeton, NJ, 1-6.

Hughes, S. W., Tippett, D. D. & Thomas, W. K. (2004). Measuring project success in the construction industry. *Engineering Management Journal*, Vol. 16, No. 3, 31-37.

Jang, W.-S. & Skibniewski, M. J. (2009). Cost-benefit analysis of embedded sensor system for construction materials tracking. *Journal of Construction Engineering and Management*, Vol. 135, No. 5, 378-386.

- Kapliński, O. (2018). Innovative solutions in construction industry. Review of 2016–2018 events and trends. *Engineering Structures and Technologies*, Vol. 10, No. 1, 27-33.
- Ko, C.-H. (2010). RFID 3D location sensing algorithms. *Automation in Construction*, Vol. 19, 588-595.
- Liu, Y. (2014). Virtual neurosurgical education for image-guided deep brain stimulation neurosurgery. *Proceedings of the 2014 International Conference on Audio, Language and Image Processing, IEEE*, Shanghai, China, 623-626.
- Lu, M., Chen, W., Shen, X., Lam, H.-C. & Liu, J. (2007). Positioning and tracking construction vehicles in highly dense urban areas and building construction sites. *Automation in construction*, Vol. 16, No. 5, 647-656.
- Maffei, A. & Onori, M. (2019). Evaluation of the potential impact of fully-immersive virtual reality on production engineering curricula. *Proceedings of the Institute of Electrical and Electronics Engineers AFRICON conference*, Accra, Ghana, 1-5.
- Marks, E. & Teizer, J. (2012). Proximity sensing and warning technology for heavy construction equipment operation. *Proceedings of Construction research congress: Construction challenges in a flat world*, West Lafayette, Indiana, United States 981-990.
- Messner, J. I., Yerrapathruni, S. C., Baratta, A. J. & Whisker, V. E. (2003). Using virtual reality to improve construction engineering education. *Proceedings of the American Society for Engineering Education Annual Conference & Exposition*, Nashville, Tennessee, 1-9.
- Milgram, P. & Kishino, F. A. (1994). Taxonomy of Mixed Reality Visual Displays. *IEICE Transactions on Information and Systems*, Vol. E77-D, No. 12, 1321-1329.
- Miller, J. (2008). *Skanska Uses Vela Systems on New Meadowlands Stadium Construction Project to Unite RFID and BIM for Materials Tracking* [Online]. Cision. Available: <https://www.prweb.com/releases/2008/04/prweb821184.htm> [Accessed June, 2020].
- Oloufa, A. A., Ikeda, M. & Oda, H. (2003). Situational awareness of construction equipment using GPS, wireless and web technologies. *Automation in Construction*, Vol. 12, 737-748.
- Pan, Z., Cheok, A. D., Yang, H., Zhu, J. & Shi, J. (2006). Virtual reality and mixed reality for virtual learning environments. *Computers & graphics*, Vol. 30, No. 1, 20-28.
- Pantelidis, V. S. (2010). Reasons to use virtual reality in education and training courses and a model to determine when to use virtual reality. *Themes in Science and Technology Education*, Vol. 2, No. 1-2, 59-70.
- Psozka, J. (1995). Immersive training systems: Virtual reality and education and training. *Instructional science*, Vol. 23, 405-431.
- Radu, I. (2014). Augmented reality in education: a meta-review and cross-media analysis. *Personal and Ubiquitous Computing*, Vol. 18, No. 6, 1533-1543.
- Skanska. (2009). *Rocky Mountain Arsenal*. Available: <https://www.usa.skanska.com/what-we-deliver/projects/57219/Rocky-Mountain-Arsenal/> [June, 2020].
- Turkan, Y., Bosche, F., Haas, C. T. & Haas, R. (2012). Automated progress tracking using 4D schedule and 3D sensing technologies. *Automation in construction*, Vol. 22, 414-421.
- Turner. (2016). *Turner project team at North Eagleville Road Phase IIIA project achieves substantial completion* Turner Construction Company. Available: <https://www.turnerconstruction.com/news/item/9170/Turner-project-team-at-North-Eagleville-Road-Phase-IIIA-project-achieves-substantial-completion> [June, 2020].
- Zhang, Y. & Lu, L.-W. (2008). Introducing smart structures technology into civil engineering curriculum: education development at Lehigh University. *Journal of professional issues in engineering education and practice*, Vol. 134, No 1, 41-48.

IMMERSIVE VIDEO CAPTURE TECHNOLOGY FOR CONSTRUCTION MANAGEMENT EDUCATION

Alireza Shojaei, Saeed Rokooei, Lee Carson, George Ford

Building Construction Science, Mississippi State University, P.O. Box 6222, Mississippi State, MS 39762

Amirsaman Mahdavian

Department of Civil and Environmental Engineering, University of Central Florida

ABSTRACT: *Immersive video technologies provide a unique opportunity for transferring and experiencing the real environment at a later time and location. The immersive experience and the real image that this emerging technology presents are well suited for education and training. Previously static 360° panoramas and virtual reality environments were being used for safety training. However, the use of immersive videos as an educational tool in construction management remains mainly unexplored. This study investigated the incorporation of 360° and 180° 3D immersive videos within a construction education class. Multiple configurations of 360°, 180° 3D (with depth perception), and flat video recording were used to capture construction processes by mounting cameras on students at different body positions during their hands-on construction training. One static camera was also used to record the construction process, mounted on a tripod. Then, different delivery systems were utilized to use the videos to reinforce students' educational experiences by reviewing their own, and their peers' work processes to learn from their mistakes and to get familiar with the work they did not execute themselves. A group of construction management freshman students reviewed the footages using different delivery systems. Students' perceptions toward this educational tool were collected and analyzed through a survey. The users' feedback analysis showed that they preferred the immersive video experience over the conventional videos and valued this educational method as a complementary tool in their education. Also, the head mount display was the favorite delivery device. Overall, the results showed that the outlook of using this technology for enhancing construction management education is positive.*

KEYWORDS: *Immersive Video, 360 Video, 3D video, Construction education, Virtual site visit, Mixed Reality.*

1. INTRODUCTION

Advanced visual skills are essential for practitioners in the Architecture, Engineering, and Construction (AEC) field. Virtual Reality (VR) and simulations have been used to assist students in increasing their awareness and advancing their perceptions of different concepts in AEC. VR has numerous features, which make it an exciting tool for educational purposes. Its naturally interactive environment gives a more pragmatic learning experience than conventional type lessons such as lectures. Traditionally, lecture courses have been combined with construction site visits and internships throughout the course of a program to complement the learners' education. However, going on a site visit in a large group of students has logistical challenges as well as safety concerns. Internships also provide valuable experience to the students. However, both internships and site visits take time to implement and are not accessible to all students at all times. VR has various applications in the construction industry, including simulation of construction processes, spatial construction understanding, and construction safety. This new technology provides an immersive experience to the users and allows them to experience scenarios which might be dangerous in real life. The Head Mount Display (HMD) is one of the delivery methods for such content, which provides the experience of being in a simulated environment. Besides the immersive visuals, such a technology can provide the user with spatial audio to make the experience even more realistic. Reality capture technologies such as laser scanning and immersive pictures and videos also provide a suitable platform for creating educational content in the AEC domain. Previously, immersive static pictures, both augmented and plain, have been used for providing students with real-like educational content. However, the use of immersive videos using reality capture technology in construction management education is still in its early development compared to virtual simulations and immersive pictures. This paper discusses the development and deployment of immersive video content for construction management education by implementing this technology in a classroom and presents the initial students' perceptions and feedback regarding this educational tool using a survey.

2. RELATED WORKS

The conventional teaching method, which is comprised of lectures (mostly) based on pure text with few visual components, often fails to provide the optimal engagement between the students and the content in practical fields such as construction (Deshpande & Salman, 2016). A purely lecture-based course often fails to simulate the real-world experience of the topic under study and seems abstract. On the other hand, experiential education methods, such as active learning, are usually superior compared to learning by typical cognitive methods (Lumpkin et al., 2015). The recent advancements in technology have enabled us to put construction learners in an immersive reality-based projection replicating the real world that allows them to feel and explore with a 3D virtual model of an actual construction project. This advanced visual communication can notably enhance the capability of learners to understand, learn, and obtain construction knowledge in classrooms which were not possible before in the same setting (Eiris Pereira et al., 2019; Eiris et al., 2018).

Different applications of VR to enhance students' perceptions of construction processes have been investigated. Lucas (2018) used VR content for construction education with a focus on wood frame construction assemblies and evaluated its impact on students' understandings. The results revealed that the VR content had a positive impact on the students' understating of the process. VR has also been utilized for various safety-related applications, such as actively monitoring the site and informing laborers about the site's likely dangers (Cheng & Teizer, 2013), and transferring the safety information to laborers (Guo et al., 2012). More recently, Zhao and Lucas (2015) developed a VR platform to educate workers on electrical power hazards. The outcomes of this research confirmed better active learning by the workers using this system. Hilfert and Konig (2016) investigated the use of HMDs to test human behavior in various hazardous job situations that generally require real-life practice when instructing novice workers. Pedro et al. (2016) used virtual content in a construction class to transfer safety knowledge by mobile-based virtual simulations.

Regardless of the advantages that VR can offer, its adaptation rate is very slow. This is arguably the result of several restraints of the technical aspects of this technology including display quality and lack of realism (Schwaab et al., 2011), usability parameters (Huang et al., 2010), high recognition inaccuracy rate (Gieser et al., 2013), equipment upfront cost (Wiecha et al., 2010), content development cost (Wiecha et al., 2010), and motion sickness (Abdul Rahim et al., 2012). VR settings produce computer-generated simulations, while 360° reality capture technologies create true-to-reality simulations of situations.

360° panoramas are uninterrupted stretches of the entire area surrounding a spectator, giving a sense of presence to the individual (Bourke, 2014). 360° video is a novel technology for generating immersive reality-based content. An educational gamified application that includes such technology could contribute to more involvement of the users and improve the level of user immersion (Pham, Dao, Pedro, et al., 2018). Eiris et al. (2018) stated that 360° panoramas use low computational processes, simple content creation process, and produce realistic simulations that are immersive. 360° reality taking techniques produce an un-modeled view of the real setting that resembles the actual reality, presenting an inherent advantage compared to other virtual reality methods.

The use of 360° videos for educational purposes is gaining momentum. Argyriou et al. (2017) discussed the production of an immersive application based on a 360° video on the value of cultural heritage education. They used a gamification framework to devise appealing experiences and improve the depth of the user's immersion in virtual environments built with the 360° videos. IZARD et al. (2017) employed 360° immersive visualization of an operating and an anatomical dissection room, to produce an immersive environment for training on equipment applications. They argued that interactive and visual learning tools motivate health science students to study more and enhance their long-term memory.

Static 360° panoramas have previously been employed as a tool to visualize the safety-related aspects of construction and evaluate the severity of the dangers. Eiris Pereira et al., (2019) developed a safety education program utilizing 360° panoramas augmented by layers of information. The developed educational framework leveraged augmentations such as animations, objects, or sounds, on 360° panoramas aiming to improve hazard-identification abilities. Pham, Dao, Kim, et al., (2018) designed a static 360° panorama program to present safety-related training to learners. They verified the effectiveness of the platform by observing no analytical variations in the danger identification scores of learners who visited actual construction sites and learners who only used the immersive content. Moore et al. (2019) conducted a study to design and analyze various safety hazard identification scenarios using VR and 360° panorama techniques. Even though the users recognized VR to be cleaner and simpler to use compared to 360° content, the 360° panoramas gave a true-to-life

depiction of an actual construction site which may be messy or dirty in reality and was more beneficial than VR in expressing how a construction site and related hazards may seem in reality (Moore et al., 2019).

3. ENABLING TECHNOLOGY

The recent technology advancements played an important role in the current movement towards a more digitalized industry in order to improve efficiency, productivity, safety, and many other key performance criteria. The particular enabling technology for this research includes the immersive video capture cameras and HMDs. Table 1 presents a comparison of immersive video capture cameras and their main features. This table is not comprehensive by any means. There are different cameras available in the market, and each camera has different features. However, the chosen cameras and their main features satisfy the purposes of this discussion, which is to provide an understanding of the current technology's advantages and limitations. There are two main configurations of the immersive video capture cameras. The ones with two lenses beside each other capture 180° videos with depth perception (180° 3D), and the ones with two lenses on the opposite site capture 360° videos without any depth perception (360°). Lenovo mirage can only capture 180° 3D videos while Qoocam can record both 360° and 180° 3D videos. The rest of the cameras can only capture 360° videos. The highest video resolution possible currently is 5.2K at 30 frames per second (fps).

In this study, a mix of four cameras, namely, GoPro fusion, Lenovo Mirage, Qoocam, and GoPro Hero (depicted in Figure 1- Left) were used to better understand each camera's advantages and limitations for the purposes of this study. The GoPro Fusion was chosen to bring the highest quality video and the best camera stabilization into the mix. Lenovo Mirage was used due to its lower price and capability of recording 180° 3D videos. Qoocam was used due to its versatility and unique feature of being able to record both 360° and 180° 3D videos and having the highest battery runtime. The GoPro Hero was used to provide a comparison point between the conventional videos and the immersive ones in the study.

Table 1: Comparison of immersive video capture cameras and their features

Features	Insta360 One X	GoPro Fusion	Ricoh Theta V	Samsung Gear 360	YI 360	QooCam	Lenovo Mirage
Type of videos	360	360	360	360	360	360 / 180 3D	180 3D
Number of Lenses	2 x f/2.0	2 x f/2.0	2 x f/2.0	2 x f/2.2	2 x f/2.0	3 x f/2.2	2 x f/2.1
Max Video Resolution	5.7K @ 30fps	5.2K @ 30 fps	4K @ 29.97fps	4K @ 24fps	5.7K @ 30 fps	4K @ 60 fps	4K @ 30 fps
Photo Resolution	18 Megapixels	18 Megapixels	15 Megapixels	15 Megapixel	5760×2880	4096 x 2160	13 Megapixel
Stabilization	Yes- 6 Axis	Yes - 6 Axis	Yes- limited	No	No	yes - 3 axis	No
Memory	MicroSD up to 128GB	2xMicro SD up to 128GB	Internal only -19GB	MicroSD Card up to 256GB	Micro SD up to 256GB	Micro SD up to 256GB	MicroSD up to 128GB
Battery	60 Minutes	60 Minutes	80 Minutes	100 Minutes	50 Minutes	3 Hrs	2 Hrs
Price	\$399	\$299	\$379	\$199	\$159	\$329	\$299

The other aspect of enabling technology for this research is the content delivery method. The content can be delivered through HMD (Figure 1- Right) or can be used through conventional displays such as laptops, tablets, and phones. The videos can be played locally from the device or through broadband access by using intermediary providers such as YouTube or Vimeo. In this study, all the content delivery was conducted locally.



Figure 1: Enabling technologies, Cameras (left), HMDs (Right)

4. METHODOLOGY AND MOTIVATION

Construction processes comprise of complex tasks involving many details. It is not always possible to provide an opportunity for every and each student to gain hands-on experience on each subject. Site visits, small mock-up construction, and internships can be used to complement the lecture-based education and provide students with a more realistic perception of the work process. However, each of these solutions comes at a price and accessibility of students to them varies depending on their location, status, and connections. As a result, this study explored the incorporation of 360° and 180° 3D immersive videos in construction education by implementing the system as a complementary tool to students' hands-on construction activities and evaluate their perceptions toward this educational tool through a survey. The authors were interested in learning whether this technology might be used to capture construction processes already being done by the students and use it to transfer knowledge in order to help them to learn from their mistakes and other students' mistakes, learn the construction process, get familiar with the conditions of the job site, and construction means and methods.

This study followed an Institution Review Board approved protocol (IRB-19-170) to conduct a pilot study of trial recordings followed by evaluation through a survey by a group of freshman students in a four-year construction management program to evaluate the feasibility and students' perception of the immersive video capture technology for construction education. Trial recordings took place during the construction process of two modular tiny houses as a hand on learning method for delivering construction means and methods while getting them acquaintance to other aspects of the work such as safety, scheduling, estimating, and more. The group that participated in this study was comprised of 12 students. The students watched different configurations of videos using different delivery methods and answered 15 questions to capture their perception and initial feedback toward this technology as a complementary educational tool to their routine education process. This study follows the

4.1 Content creation process

The content creation process includes raw video capture and then processing the video. Kavanagh's, et al. (2016) case study revealed that a natural point of view is critical for 360° video creation. As a result, in this study, all the video capture configurations in terms of the camera's point of view designed to be at head level to provide a natural point of view for the users. Two main approaches were tested in terms of the camera location, mounting the camera to a user and mounting the camera on a tripod. Figure 2 depicts the different configurations of the cameras' positions. Figure 2 (A) and (D) depict the use of shoulder mounts while Figure 2 (B) and (C) depict the use of helmet mounts for content recording. Figure 2 (E) shows a camera mounted on the tripod. The user mounted cameras were used to provide a close look at the user work process while the tripod-mounted camera was used to provide a more holistic view of the job site and simulate the job site surrounding experience for the final users.



Figure 2: Different camera positions

The video processing in this study was done through each camera's proprietary software. The 360° videos were compiled through stitching two 180° videos, and the 180° 3D ones were compiled through combining the videos from two adjacent lenses together. Most of the cameras have image stabilizers built-in and stabilize user movements. However, it is also essential to use a digital stabilizer during processing to ensure the final users will not get sick when they are watching the videos. One notable issue is the importance of the fps when the user is experiencing immersive videos using HMDs. Lower fps could potentially make users nauseated and make them feel sick. There is a trade-off between the video quality and fps as higher quality videos will be captured with lower fps and lower quality videos can use higher fps. Finding the right balance between the quality of the video and fps, considering the current limitations of the technology is a challenge that needs to be carefully considered before any video capture trials.

5. IMPLEMENTATION AND RESULTS

In contrast to VR content development where the developer controls everything, recording real-time 360° video is prone to capturing unwanted and even wrong scenarios. The video needs to be directed closely according to a previously decided scenario if the purpose is to convey a particular message in a specific way. In other words, to control the content, the creators need to control the real-time workflow in a pre-defined scenario. Multiple data collection trials were conducted where construction management freshman students were building a modular tiny house as a hands-on learning method. Figure 3 depicts a sample of a wide view 180° 3D video captured in one of the trials. The top image shows how two separate lenses see the job site and how it appeared in an HMD. The bottom picture shows the output video if the video is compiled for reviewing with a laptop or other flat-screen devices. The wide view data collection (depicted in figure 3) is aimed to capture the whole environment of the construction job site and its surrounding, so the users can experience it before even setting foot to an active job site.



Figure 3: A sample of the wide view 180° 3D videos

Another configuration of data collection was close takes from the actual workflow using 180° 3D cameras. Figure 4 depicts an example of the close take 180° 3D videos. These videos intended to provide the users with a more detailed view of the actual construction work process with an immersive and close to real-life detail and feel.



Figure 4: A sample of the close take 180° 3D videos

The last video configuration was the use of 360° cameras for data collection. The 360° videos were used only for close take of the construction process in this study. Figure 5 depicts two sample views of the 360° footage. It should be noted that the videos are spherical and depending on the delivery device, the user can rotate the viewpoint and watch any point of interest in the videos.



Figure 5: Two sample views of the 360° videos

The collected and processed videos were shown to a group of 12 freshman construction management students to experience different video configurations with different delivery methods (HMD and Laptop). Then, the students' perception and initial feedback regarding this technology as an educational method were collected and analyzed through a survey comprised of 15 questions. Following is the summary of the findings based on their feedback.

Table 2 presents the first six questions of the survey, which were Yes/No questions, and their results. All the students agreed that the quality of the videos was satisfactory (Q1). Also, it is evident that students saw a difference in the perceived information from different formats (Q2). This shows that while the students agreed that all the video configurations produce satisfactory quality, but the amount of knowledge transfer is different in them. This issue will be further investigated in question 7 to better understand their perception about the best configuration. The majority of the students (%92 percent, 11 students) chose that they would like to use this technology as an educational method (Q3). All the students agreed that the spatial sound helped in better experiencing the construction environment (Q4) and the majority of them (%92 percent, 11 students) agreed that the spatial sound provides more awareness of the construction site surroundings surrounding (Q5). Two students reported that they felt uncomfortable during the videos, while the majority (%83, 10 students) did not feel uncomfortable (Q6).

Table 2: Survey questions 1-6 and results

No.	Question	Yes	No
1	Is the quality of the videos satisfactory?	% 100 (12)	0
2	Do you see or perceive more information in different formats?	% 100 (12)	0
3	Would you use this system to learn about construction means and methods?	% 92 (11)	% 8 (1)
4	Does spatial audio help you in better experiencing the environment?	% 100 (12)	0
5	Does spatial audio provide more awareness about the construction site surroundings?	% 92 (11)	% 8 (1)
6	Did you feel uncomfortable during the videos?	% 83 (10)	% 17 (2)

Questions 7-10, presented in table 3, had multiple choice answers in which students could only pick one. These questions were designed to better understand the students' perception toward the different configurations of training videos and delivery methods. Seven students (%58) chose 360 videos as being more informative, while five students (%42) chose 180 3D videos, and most interestingly, none chose conventional flat videos (Q7). It clearly shows that immersive videos had an advantage over the conventional flat videos. Each student chose the same answer in question 8, where they were asked about the attractiveness of each video configuration. It can be deduced that there is a correlation between the perceived level of information and the attractiveness of each video configuration. The majority of students (%83) preferred having instruction naturally within the videos instead of having them added to the video later. (Q9). A majority of previous studies (such as Eiris Pereira et al., 2019; Eiris et al., 2018; Pham, Dao, Pedro, et al., 2018) that utilized immersive technologies in construction education had instruction and information augmentation added to the content as a post-capture process. This was mainly due to the fact that their content was based on static panorama pictures. This shows that immersive videos have the potential to be more attractive and informative compared to the commonly used static panoramas. The majority of the students (%83) preferred HMD as their favorite delivery method (Q10). The two students who reported they felt uncomfortable during the videos in question six preferred laptops as their favorite delivery method.

All the students except one stated that the HMD was their favorite delivery method as it was more immersive and they could easily change the viewpoints and focus on any point of interest. One student reported that the HMD made him feel sick, and he preferred using a laptop to review the videos.

Table 3: Survey questions 7-10 and results

No.	Question	Choices		
7	Which video configuration was more informative? (flat video, 180 3D, 360)	360 %58 (7)	180 3D %42 (5)	Flat (0)
8	Which Video format is more attractive?	360 %58 (7)	180 3D %42 (5)	Flat (0)
9	Is it better to have instructions within the video or added after the video?	Within %83 (10)	After %17 (2)	-
10	What was your favorite delivery method? Head mounted display (HMD) or laptop	HMD %83 (10)	Laptop %17 (2)	-

Table 4 presents questions 11 and 12 with their results. These two questions were designed based on a Likert scale to measure students' overall evaluation and usefulness of this technology in construction education in a more quantitative manner. The results show that students' overall evaluation of immersive videos as an educational method was positive (Q11) and they found this technology to be useful in construction education (Q12)

Table 4: Survey questions 11,12 and results

No.	Question	Mean	Mode	S.D.
11	What is your overall evaluation of this educational method? Likert (5-1)	4.42	5	0.64
12	How useful do you see such technologies to be used in construction education? Likert (5-1)	4.33	5	0.94

The last part of the survey were three open-ended questions (questions 13-15 presented in table 5) to capture students' feedback about the challenges, most interesting aspects, and suggestions for future use of this technology in construction education. The availability of HMD headsets and rare blurriness of video when the camera moves too much were identified as the main challenges by the students (Q13). Being so realistic and providing a better perspective in 3D format were identified as the most interesting aspects of this technology (Q14). Augmenting the videos with transcripts, better audio, and creating videos of ways no to do tasks as well as the right ways to do them were identified as suggestions to better use these tools in construction education (Q15). A few other comments made by students read as "feels like you are there", "in 3D view you can see everything happening around you all at once", "the videos help in explaining the process".

Table 5: Survey questions 13-15

No.	Question
13	What challenges do you see in using such technologies?
14	What is the most interesting aspect of these tools?
15	What do you suggest to better use these tools in construction education?

VR and immersive videos provide unique applications for education and many other areas. However, the use of them can cause different types of safety hazards if not implemented properly. It is paramount that educators take extra caution when they are deploying such a technology in their classrooms. These safety hazards can be categorized into physical and physiological. Posture, hygiene, and immersion injuries are among the physical ones. Immersion injuries such as spatial collision are important when multiple users are immersed in a virtual

environment and are operating in each other vicinity. The users are technically blind in the real world, and there is a possibility that they collide with each other if the safe operation of multiple users is not carefully planned beforehand. In such cases, it is recommended to use designated physical space for each user to minimize the risk of collision. Furthermore, a third party observer can be used to intervene when two users get close to each other. Physiological issues include visual and motion sickness. It is recommended that students take some time to get familiarized with the virtual world before the start of the educational experience. Also, they need to be aware of the motion sickness symptoms so they can stop the experience before pushing themselves over their limits.

6. CONCLUSION AND FUTURE WORK

This study implemented immersive video capture (360° and 180° 3D) in a freshman construction management class as a complementary tool to the students' conventional education and evaluated the students' perception and initial feedback through a survey. The results showed that the outlook of using immersive videos for construction education is positive. Students reported that they perceived a different amount of information in different configurations. Most of them preferred 360 videos, closely followed by 180 3D videos. Also, it was observed that spatial sound helped the students to get a better feeling and understating of the soundings. High-quality videos with high frame rates are a critical underlying requirement for this technology to become useful. The quality level that the currently available equipment can produce is satisfactory. However, improvement in this area will impact user acceptance and the wide adaptation of this technology as an educational method. An advantage of this educational method is the much higher outreach and increase accessibility due to the possibility of using broadband and remote access to the material, which would give the user an immersive and real-like experience of the content without being near there. Future work for this research includes a more in-depth study with more participants and a more comprehensive survey followed by quantitative analysis with a comparison of conventional educational methods, virtual simulations, and augmented static panoramas. Content creation from multiple viewpoints of the same content to allow the user to change the viewpoint plus gamification of the content using rules and user interfaces is also part of the future direction for this study.

7. REFERENCES

- Abdul Rahim, E., Duenser, A., Billinghamurst, M., Herritsch, A., Unsworth, K., Mckinnon, A., & Gostomski, P. (2012). A desktop virtual reality application for chemical and process engineering education. *Proceedings of the 24th Australian Computer-Human Interaction Conference*, 1–8.
- Argyriou, L., Economou, D., & Bouki, V. (2017). 360-Degree Interactive Video Application for Cultural Heritage Education. *Online Proceedings from the Third Immersive Learning Research Network Conference*, 297–304. <https://doi.org/10.3217/978-3-85125-530-0>
- Bourke, P. (2014). *The Panorama: Applications to Science and Heritage Visualization*. Lawrence Wilson Art Gallery. Available Online: [Http://Paulbourke.Net/Papers/Lawrencewilson/](http://Paulbourke.Net/Papers/Lawrencewilson/).
- Cheng, T., & Teizer, J. (2013). Real-time resource location data collection and visualization technology for construction safety and activity monitoring applications. *Automation in Construction*, 34, 3–15.
- Deshpande, A., & Salman, B. (2016). Think-pair-share: Application of an active learning technique in engineering and construction management classes. *Proc. Annu. Int. Conf. Assoc. Schools Construct.*, 1–7.
- Eiris Pereira, R., Moore, H. F., Gheisari, M., & Esmaeili, B. (2019). Development and Usability Testing of a Panoramic Augmented Reality Environment for Fall Hazard Safety Training. In *Advances in Informatics and Computing in Civil and Construction Engineering* (pp. 271–279). Springer International Publishing. https://doi.org/10.1007/978-3-030-00220-6_33
- Eiris, R., Gheisari, M., & Esmaeili, B. (2018). PARS: Using Augmented 360-Degree Panoramas of Reality for Construction Safety Training. *International Journal of Environmental Research and Public Health*, 15(11), 2452. <https://doi.org/10.3390/ijerph15112452>
- Gieser, S. N., Becker, E., & Makedon, F. (2013). Using CAVE in physical rehabilitation exercises for rheumatoid arthritis. *Proceedings of the 6th International Conference on PErvasive Technologies Related to Assistive Environments*, 1–4.

- Guo, H., Li, H., Chan, G., & Skitmore, M. (2012). Using game technologies to improve the safety of construction plant operations. *Accident Analysis and Prevention*, 48, 204–213. <https://doi.org/10.1016/j.aap.2011.06.002>
- Hilfert, T., & König, M. (2016). Low-cost virtual reality environment for engineering and construction. *Visualization in Engineering*, 4(1). <https://doi.org/10.1186/s40327-015-0031-5>
- Huang, H.-M., Rauch, U., & Liaw, S.-S. (2010). Investigating learners' attitudes toward virtual reality learning environments: Based on a constructivist approach. *Computers & Education*, 55(3), 1171–1182.
- Izard, S. G., Méndez, J. A. J., García-Peñalvo, F. J., López, M. J., Vázquez, F. P., & Ruisoto, P. (2017). 360° vision applications for medical training. *Proceedings of the 5th International Conference on Technological Ecosystems for Enhancing Multiculturality - TEEM 2017*, 1–7. <https://doi.org/10.1145/3144826.3145405>
- Kavanagh, S., Luxton-Reilly, A., Wüensche, B., & Plimmer, B. (2016). Creating 360° educational video. *Proceedings of the 28th Australian Conference on Computer-Human Interaction - OzCHI '16*, 34–39. <https://doi.org/10.1145/3010915.3011001>
- Lucas, J. (2018). Immersive VR in the construction classroom to increase student understanding of sequence, assembly, and space of wood frame construction. *Journal of Information Technology in Construction*, 23(November 2017), 179–194.
- Lumpkin, A., Achen, R. M., & Dodd, R. K. (2015). Student perceptions of active learning. *College Student Journal*, 49(1), 121–133.
- Moore, H. F., Eiris, R., Gheisari, M., & Esmaeili, B. (2019). Hazard Identification Training Using 360-Degree Panorama vs. Virtual Reality Techniques: A Pilot Study. *Computing in Civil Engineering 2019*, 55–62. <https://doi.org/10.1061/9780784482421.008>
- Pedro, A., Le, Q. T., & Park, C. S. (2016). Framework for Integrating Safety into Construction Methods Education through Interactive Virtual Reality. *Journal of Professional Issues in Engineering Education and Practice*, 142(2), 04015011. [https://doi.org/10.1061/\(ASCE\)EI.1943-5541.0000261](https://doi.org/10.1061/(ASCE)EI.1943-5541.0000261)
- Pham, H. C., Dao, N.-N., Kim, J.-U., Cho, S., & Park, C.-S. (2018). Energy-efficient learning system using web-based panoramic virtual photoreality for interactive construction safety education. *Sustainability*, 10(7), 2262.
- Pham, H. C., Dao, N., Pedro, A., Le, Q. T., Hussain, R., Cho, S., & Park, C. (2018). Virtual field trip for mobile construction safety education using 360-degree panoramic virtual reality. *Int. J. Eng. Educ*, 34(4), 1174–1191.
- Schwaab, J., Kman, N., Nagel, R., Bahner, D., Martin, D. R., Khandelwal, S., Vozenilek, J., Danforth, D. R., & Nelson, R. (2011). Using second life virtual simulation environment for mock oral emergency medicine examination. *Academic Emergency Medicine*, 18(5), 559–562.
- Wiecha, J., Heyden, R., Sternthal, E., & Merialdi, M. (2010). Learning in a virtual world: experience with using second life for medical education. *Journal of Medical Internet Research*, 12(1), e1.
- Zhao, D., & Lucas, J. (2015). Virtual reality simulation for construction safety promotion. *International Journal of Injury Control and Safety Promotion*, 22(1), 57–67. <https://doi.org/10.1080/17457300.2013.861853>

Part4. Building Information Modelling

CONVERTING OPEN STANDARD CAD FORMATS INTO DECENTRALISED COMMON DATA ENVIRONMENT

*Stephen Oliver & Farzad Pour Rahimian & Nashwan Dawood & Sergio Rodriguez
Teesside University, England*

*Saleh Seyedzadeh
University of Strathclyde*

ABSTRACT: *Communication plays a significant role in the success of construction projects, companies and overall industry performance. Quality of communication can affect inter-organisational relationships outwith and beyond individual projects, and failures to share information effectively or even consistently can cascade into disruptive conflicts. Standard data exchange formats help bridge interpretation gaps resulting from vendor-locked data formats regardless of communication efficiency, but they are only an improvement in the data structure, not communication. Common data environments are said to remedy several critical communication/social identity conflict sources through privileging all project stakeholders with mutual omniscience of a project's information ecosystem. In the construction industry, a common data environment, OpenBIM, is a precursor to the NBS BIM level 3. Previous research has demonstrated a centralised BIM server based on the IFC data fulfils the OpenBIM prerequisite. However, the existing research only fulfils of the first two sublevels on the NBS scale. The third, encapsulating autonomous organisations, requires a paradigm shift from trust in data to confidence which currently can only reasonably be achieved through decentralisation of the BIM model. This paper presents a method for creating BIM 3c-ready common data environments from existing open standards. A case study using the .dxf open standard was documented to demonstrate the transferable method.*

KEYWORDS: *Distributed ledger technologies, OpenBIM, Common data environments*

1. Introduction

Communication quality and trust play significant roles in the success of projects and the interorganisational relationships formed during them. In their most tangible form, communication failures have been observed to contribute on average 3% to 5% of project capital expenditure (Wu *et al.*, 2017). In more confounding contexts, the richness, salience and consistency of interactions can affect whether conflicts are settled or resolved (Oliver, 2019).

Common data environments (CDE) are fast becoming popular for collaboration, even in the construction industry which typically is one of the slowest in innovation uptake. Software-as-a-solution platforms offer access-anywhere building stock management, smart grids share node operational data for buying and selling energy from on-site renewable energy systems, even social media-style instant messaging has found its way into standard operating procedures. Some research CDEs for CAD/BIM virtual models, however, appear to be in relative infancy. Several software vendors offer modular software with some form of moderately low-latency data synchronisation, but they fall short on interactive virtual environments. Autodesk, for example, offers BIM360 for merging virtual models. The software supports semi-autonomous and low latency synchronisation, visualisation, and standardisation but not interactivity.

Du *et al.* (2018) demonstrated a two-way link between Autodesk's Revit and the Unity Game engine. They replicate assemblies from Revit as Unity prefabs to facilitate moving and rotating entities and insert/replace. Pour Rahimian *et al.* (2019) demonstrate a similar model built around the Industry Foundation Classes which reconstructs the planar geometry of the IFC model to bind the BIM model to the triangular mesh representations.

Pour Rahimian *et al.* (2019) demonstrated a proof of concept OpenBIM server with read-write user concurrency. In their framework, they designated a machine to take the role as the server to which all user interfaces connect, including the host. Users submit requests to modify the model state which if approved by the server, are distributed to the user interfaces to action in their environments. Their research demonstrates that OpenBIM can be achieved without scrapping existing standards which the standard can be improved rather than replaced. However, concurrent read-write access is only one feature of the bigger OpenBIM picture which is envisaged by the UK government to include confidence-based data management and decentralised autonomous organisations.

Both of which cannot be supported by centralised common data environments. Short of physically co-signing each environment state change, the confidence-based data management can only be facilitated by decentralised databases.

This paper furthers Pour Rahimian *et al.* (2019) 's research on centralised OpenBIM using the existing IFC standard data exchange formats by demonstrating how existing standards formats may be converted to a decentralised common data environment. In doing so, it demonstrates how trust-based data management can be replaced with confidence-based and subsequently how the UK government's vision may be introduced to the design phase.

The paper begins with a short literature review on communication and decentralised databases such as Blockchain. It proceeds by discussing the modifications to the model storage process is recorded, using the data exchange format (DXF) for illustration. A simple AutoLISP script is developed to generate insertion and modification records on the database. A simple Permissioned distributed ledger infrastructure is described. The paper concludes with notes on the limitations of the research and a summary of the paper's content.

2. Literature

Communication efficacy and trust play significant roles in the success of projects and the interorganisational relationships formed during them. They are the In their most tangible form, communication failures have been observed to contribute on average 3% to 5% of project capital expenditure (Wu *et al.*, 2017). In more confounding contexts, the richness, salience and consistency of interactions can affect whether conflicts are settled or resolved (Oliver, 2019, Calefato and Lanubile, 2010).

Communication and trust have a reciprocal relationship where excellence in one may mitigate periods of volatility in the other. The long-term development of 'generalised' trust may provide resilience to periods of volatility in the predictability of interaction outcomes between two or more parties (Trope and Liberman, 2010). Intergroup communication is suggested to mitigate some of the cultural barriers of trust in international collaborations (Pettigrew, 2008) The efficacy of which is in some way attributed to (Calefato and Lanubile, 2010) the relevant richness of communication (Dennis and Kinney, 1998) or the salience of the respondent's presence during interactions (Gunawardena, 1995). A collection of features particularly relevant to construction projects where perceptions of risk are said to be bound to social identity and ultimately trust as defined by Cheung *et al.* (2011) for construction projects, the willingness of share information. The risk association described by (Cheung *et al.*, 2011) where social identity disincentives groups from taking ownership of activity outcomes, may be alleviated by distributed ledgers. Distributed ledgers are in direct conflict with some intergroup interaction problems and traditional risk-sharing as trust is replaced with confidence in the data and equivocality with factualness.

One proposed solution to CAD/BIM and other challenges in the construction industry is distributed ledgers (Sund *et al.*, 2020, Theodoros Dounas, 2017, Hunhevicz and Hall, 2020). These decentralised immutable databases are updated by consensus on the outcome of transactions, which means a project state change is only achieved once it is accepted by all invested parties. If one is generous it should be seen not that intergroup risk aversion is no longer an important option but rather the equal measurement of fallibility, everyone's actions can be traced for ownership whether subordinate or coordinator and everyone agrees events occurred before they are broadcasted.

Distributed ledger technologies are not without conflict with courteous leniency in the event of an error and, in broader terms, social identity. Piroozfar *et al.* (2019) interviewed fifty-eight BIM practitioners with one encapsulating the concerns regarding one of their clients "Very aggressive client, an individual ran the project by trying to [sic] instil fear of humiliation into each of the consultants and then the contractor.". The statement highlights how the immutable quality may be exploited as the granularity of recording is shifted from operation to activity and actors notarise their every action. On the surface, it is a personal burden that is expected from the employer, but it conflicts with the interests of the employer when the employees are reluctant to share their work, i.e, their data. It is also in competition with employer-employee trust as it relates to job security, and as would be expected, strengthening the desirability of unions (Noda, 2020). The distrust may in some way be linked back to a perceived psychological distance in a similar theme to the salience of mediated communication. Hypotheticality, the distance attributed uncertainty is only exacerbated by everincreasing, largely out of context record of an individual's activities. It might affect collaborations and general employee dyadic relationships; employee A cannot act on behalf of employee B discretely.

Some research has suggested that creating CAD/BIM CDEs as the starting point digital twinning would result in disruptive innovation in the construction industry as unbounded media richness and salience potential could be leveraged by any interested party to improve communications (Oliver, 2019). Du *et al.* (2018) demonstrated a framework supporting concurrency features absent from existing systems linking Revit and a virtual environment built with Unity 3D. Their system facilitating insertion and positional updates with like-for-like, with material ensured object material retention, models using the Revit application programming interface. Pour Rahimian *et al.* (2019) proposed a framework for an open standard (IFC) based centralised CDE demonstrating how a shared interactive virtual environment may be maintained by delegating operations to a surrogate data structure host. In the case of Zou *et al.* (2018), linking the interfaces, in the case of (Pour Rahimian *et al.*, 2019) the interfaces are ignorant of each other.

Although CDEs for CAD/BIM are in their infancy, there is an indication that novel versions will be legislated soon. The UK, for example, has made asynchronous managed 3D environments (UK BIM level 2 - PAS 1192) a minimum requirement for construction project CAD data. The UK's ambition for their level 3 which while not yet clearly defined, (Du *et al.*, 2018, Pour Rahimian *et al.*, 2019) targets OpenBIM. Other criteria involving communication encompassed by the collaborative component of BIM paradigms require changes in the information ecosystem from trust-based agreements to state-based contracts.

2.1 Distributed ledgers

Distributed ledgers, first proposed by (Haber and Stornetta, 1991) as a mechanism for trustworthy digital document timestamping, are a peer-to-peer network of devices where every node hosts a synchronised copy of an immutable database. Concerning this paper, they are meaningfully distinct from centralised databases in two ways 1) they are immutable 2) no one user can update the database's content without consensus on the outcome between many nodes.

In a typical public ledger, whenever one or more nodes want to update the ledger, they transmit a request to add one or more transactions to the ledger. The transaction is verified by other nodes on the network and collated by special nodes who determine whether the transaction should be approved. The mechanism used for updating a ledger is dependent on the design and purpose of the ledger. On ledgers like Bitcoin, special nodes called miners compete to collate transactions and propose the next block to be added to the chain. Whichever node owns the accepted block receives a reward for their efforts. The infrastructure in isolation has numerous weaknesses which make it unsuitable for public ledgers since there would be almost no time or monetary cost for malicious nodes attempting to exploit the network. These problems are mostly remedied through the introduction of a proof system which miners must satisfy to have their blocks accepted and receive the subsequent reward (Bentov *et al.*, 2014, Fan and Chai, 2018, NovaCoin, 2015, PeerCoin, 2020). These proof systems can be thought of as proof of investment in producing an untampered block.

Bitcoin (Nakamoto, 2009), the cryptocurrency built on a public ledger, requires that miners demonstrate investment in their block proposal's integrity in the form of a Hashcash (Back, 2002) proof-of-work puzzle. The puzzle form at Before the miner can nominate its block it must find an alphanumeric string which when the hash of concatenating it with a given string results in a given number of preceding zero-value bits in the hash; the difficulty of the challenge maintained by the required number of preceding zero-value. This type of puzzle has no known solution with time complexity of at least 2^N operations, a puzzle whose best solution cannot beat a computationally infeasible brute force attack. The probability of finding a solution were forty preceding zeroes required is roughly one in a trillion which makes finding one computationally expensive with no guarantee of being the first node to solve the puzzle. Blockchain uses the longest proposed chain rule (Courtois, 2014) in the event two or more miners solve the puzzle simultaneously and the history does not match to reach consensus on which chain is valid. The puzzle's given string is a function of the previous block which means if a node changes the content of an earlier block, it must also solve the revised puzzles for all preceding blocks and the current block (Steinbrecher and Köpsell, 2003) before it can propose a chain of blocks which could redefine the transaction history on the chain. Nonetheless, no chain history is truly secure, only secure beyond reasonable doubt (Malin (2008). Courtois (2014) suggests the longest chain rule is not the right decision, noting the Least Common Mechanism (Saltzer and Schroeder, 1975) security paradigm, minimises the mechanism common to more than one user and depended on by all users to reduce opportunities for security exploits, suggests solving both proof-of-investment and correct history problems may be a security concern. Courtois (2014) additionally noting, it is very unlikely that the best solution to one problem is the best for the other.

Other ledgers including NovaCoin (NovaCoin, 2015), BlackCoin (Vasin, 2014) and PeerCoin (PeerCoin, 2020) implement proof-of-stake protocols. Nodes intent on proposing blocks demonstrate investment by escrowing a certain amount of currency, often additionally having time-sensitive value, as a bond. If they are suspected to be acting maliciously, they forfeit the bond. Proof-of-stake also exists in the more democratic form of delegated-proof-of-stake (Fn and Chai, 2018) where those with a proof stake vote for a node in a subset of all nodes with block generation permissions. Some distributed ledger's block mining permissions systems are hybrid combinations of proof-of-stake and proof-of-work, such as proof-of-activity (Bentov *et al.*, 2014) which let miners compete to make a valid block header but not the content of the block whose data is processed by one or more other nodes proposing the content to the winning miner.

In addition to the public ledger network permissions, there are two other permissions systems, Private or Federated (Permissioned/Consortium). In the case of the former, permission to participate in the network is invitation only and, in the latter, individual permissions are assigned on a node by node basis (Li *et al.*, 2018). These can be less susceptible to common security issues since the participants and/or participants' activities are controlled.

2.1.1 Distributed ledgers in construction

According to a recent journal article (Hunhevicz and Hall, 2020), the application of distributed ledgers in construction is purely theoretical with few case studies available. The research also explains many opportunities for distributed ledger's application, grouping those they identified into seven groups: Internal administration, Automated transactions (Das *et al.*, 2020), Immutable transaction histories, Immutable asset ownership histories (Sund *et al.*, 2020), incentive schemes- based currency, decentralised apps and decentralised autonomous organisations.

Smart grid systems harness features of distributed ledgers that fall within several of the groups proposed by (Hunhevicz and Hall, 2020) where the system needs to know and validate the state of other nodes on the grid and prove transactions were processed. This decentralised software buys and sells renewable energy from sites' renewables where generated energy may be more efficiently used by a site with different spatial and operational parameters.

Integrated project delivery using distributed ledger technology and smart contracts, scripts that can be added to the ledger during operation. Elghaish *et al.* (2020) leverage distributed ledger technologies and smart contracts to manage the delivery plan's financial transactions. They also propose a compensation model which is built into the distributed ledger that may analyse project states to nominate incentive to stakeholders. The framework they describe inherently requires the decentralisation or notary type qualities of distributed ledgers for proving agreements, and the project event history.

Theodoros Dounas (2017) suggests there are four levels to CAD/BIM integration of distributed ledgers, an action log, on-ledger calculation, embedding the ledger directly into existing CAD software, and a ledger-embedded CAD/BIM. He notes the lack of commercial solutions and few academic projects relating to decentralised CAD/BIM systems as the impetus for their proposition and to demonstrate a solution for the first two levels. Elghaish *et al.* (2020) similarly note from the literature that CAD/BIM would be an important development for distributed ledger IPD models. Erri Pradeep *et al.* (2019) elaborate that distributed ledgers at the CAD/BIM stage would resolve many common BIM workflow problems by instilling confidence in the data with traceability and transparency.

3. Methodology

In this paper, a prototype CDE file format is built upon a distributed ledger which is demonstrated via an extension to AutoCAD using a small AutoLISP event script. For the sake of demonstration, the data exchange format (DXF) which preceded industry foundation classes (IFC) as the open standard CAD format is used to represent unique entities. Each distinct entity in the virtual environment is represented on the ledger as an entity definition block with a unique ID which contains its physical definition, any predefined metadata or external reference identifiers. Whenever an entity is inserted to the virtual environment, a new X-Ref record is created which assigns a unique ID to the entity instance and tracks its physical state via its position on the world coordinate system, its orientation and the ID of the user who created it. Future updates including deletion of an entity instance are performed by creating modification records which either dictate the updated state of the properties of the insert definition or blocks of subentity DXF properties, '(8 . "some_layer_name")' to modify

an entities layer for example. Whenever a user opens the model, its operations are iteratively performed in the order they appear in the ledger. A virtual ledger network is simulated using a simple for-purpose Ruby programming language which uses a gossip protocol for message dissemination and 51% consensus for transaction approval.

3.1 AutoCAD ledger interface

```
(defun makeQuery (queryType conditions properties / query where properties log)
  (setq query (strcat (strcase queryType) " userKey=" USER_CREDENTIALS ""))
  (where ""
    queryProperties "")
  (if conditions
    (progn
      (foreach condition conditions
        (setq conditionValue (if (listp (cdr condition))
          (vl-prin1-to-string (cdr condition))
          (vl-string-subst "" "" "" (cdr condition)))
          where (strcat where " AND " (nth 0 condition) "=" conditionValue ""))))))
  (if properties
    (progn
      (foreach property properties
        (setq propertyValue (if (listp (cdr property)) (vl-prin1-to-string (cdr property)) (cdr property))
          queryProperties (strcat
            queryProperties " " (car property) " = " propertyValue ""))))))
  (strcat query "\nWHERE" where "\nSET " queryProperties ";"))
(defun createObject (reactor data / entData entID entOrigin entRotation)
  (setq entData (entget (nth 1 data))
    entOrigin (cdr (assoc 10 entData))
    entID (cdr (assoc 5 entData)))
  (makeQuery "CREATE"
    (list (cons "id" entID))
    (list (cons "origin" entOrigin)
      (cons "rotation" entRotation)
      (cons "definition" entData))))
(defun removeObject (reactor data /)
  (makeQuery "DELETE" (list (cons "id" (cdr(assoc 5 (entget (nth 1 data)))))) nil)
(defun modifyObject (reactor data / entID entData entOrigin entRotation)
  (setq entData (entget (nth 1 data))
    entID (cdr (assoc 5 entData))
    entOrigin (cdr (assoc 10 entData)))
  (makeQuery "UPDATE"
    (list (cons "id" entID))
    (list (cons "origin" entOrigin)
      (cons "rotation" entRotation))))
```

Fig 1. AutoLISP query generation

```
(if dbReactorCreate (vlr-remove dbReactorCreate))
(if dbReactorUpdate (vlr-remove dbReactorUpdate))
(if dbReactorRemove (vlr-remove dbReactorRemove))
;Add database reactors
(setq dbReactorCreate (vlr-acdb-reactor "Object creation reactor"
  '(:vlr-objectAppended . createObject)))
dbReactorRemove (vlr-acdb-reactor "Object deletion reactor"
  '(:vlr-created . removeObject))
dbReactorUpdate (vlr-acdb-reactor "Object modify reactor"
  '(:vlr-objectModified . modifyObject))
```

Fig 2. AutoLISP event management

Figure 1 shows the AutoLISP, AutoCAD’s Lisp-like language, the process for generating queries ledger transactions. As seen in Figure 2, the creation of queries is delegated to the ACAD entity database event handler such that new objects are treated as insertions, existing entities are modified and deleted object are flagged as removed.

3.1.1 Data structures

The first block (genesis block) contains the project arbitrary metadata related to the site along with its relative world coordinate system origin. Proceeding blocks contain JavaScript Object Notation (JSON) formatted records of users’ activities in the virtual environment. Transactions records represent one of the create, read, update and delete (CRUD) actions, each indicating an event in the history of a single entity. Figure 3 shows the structure of a transaction. The properties identify the user who acted, what action they performed, on which object, what are the object’s physical position properties and supplementary DXF formatted data. The positioning data suited to external reference modelling typical of BIM which can be enforced to a lesser extent in IFC. The DXF properties

field “def” is where the user might add additional information in a text field or change other properties that does not affect the entity directly such as layer.

```
{
  "user":      "<string, not null>",
  "action":    "<string[:CREATE, :READ, :UPDATE, :DELETE], not null>",
  "object":    "<integer, not null[:UPDATE, :DELETE]>",
  "x":         "<real, not null[:CREATE, :UPDATE]>",
  "y":         "<real, not null [:CREATE, UPDATE]>",
  "z":         "<real, not null [:CREATE, UPDATE]>",
  "xR":        "<real, not null [:CREATE, UPDATE]>",
  "yR":        "<real, not null [:CREATE, UPDATE]>",
  "zR":        "<real, not null [:CREATE, UPDATE]>",
  "def":       "<string, not null[:CREATE]>"
}
```

Fig 3. CRUD action transaction format

This metadata handling has been leveraged to reduce the number of distinct properties which are necessary for each insert/modification record. The definitions column. Instead, a text field for modifications is added to the default columns which is expected to store DXF individual or hierarchical lists. In the AutoCAD environment, the assoc method is used to find the existing property definition in the DXF object and the entmod method used to switch out the existing value with the new. This method can be leveraged to add entity instance-specific properties, associated physical asset condition description, for example.

3.1.2 The distributed ledger

A simple for-purpose virtual ledger network was created in Ruby which implements rudimentary forms of features and protocols described previously. Each node is assigned a structured repository representing the ledger and facilitating the communication system. Each node listens to its respective messages folder for a new block of transactions proposed by any node, processing each in the order they arrive. When a new block is received, the file it is stored in is named by the ID for the messenger node.

The purpose of the ledger is to allow pre-approved users to modify the content of the shared environment while ensuring transactions are never altered once they have been committed to the ledger. Since users cannot predict the future and their investment in document integrity are shared, the permissions system can be and is Private.

The secondary consensus mechanism on Bitcoin which, in the event of a deadlock between to differing blocks which are the network agreed are valid, will fall back on the longest chain to decide which ledger is correct. In contrast, this ledger should never be rolled back under any circumstance. To implement a distributed concurrence between nodes, the ledger implements fork-consistency. This means that in the event a subset of nodes disagrees with the state of the ledger, they are forked into their group, users with different states cannot view each other’s ledger changes from the point of forking.

Dissemination of the messages needs to reach all active nodes for every proposed transaction. This was achieved by implementing the gossip-protocol. The protocol, occasionally referred to as the epidemic protocol, replicates how information is spread amongst peer groups. This project used an eager epidemic-based where every node spreads the same message to every other node on the network.

Nodes reach assume consensus is reached transactions’ validity when the number of messages agreeing with them accounts for at least 51% of all nodes.

4. Discussion

This section considers how this project aligns with the CAD/BIM integration of distributed ledgers levels introduced by Theodoros Dounas (2017).

The first is a basic representation of the virtual environment’s state. The data structure described in the previous section represents the state the model in such a way that there is no dependence on any interfacing application. It also maintains the register of the contained entities’ lifecycle. In the AutoCAD example, entity actions are monitored using AutoLISP’s vl-reactors, the mechanism for defining events in AutoCAD, ObjectARX¹ notwithstanding. Whenever an entity is created or modified the appropriate event is triggered to extract the

relevant properties and send them to the ledger.

The second is to be able to perform read-only operations on the entities in the CDE directly and can interact with external systems without a mediating interface. The description from (Theodoros Dounas, 2017) offers a smart contract which finds the highest point on a registered plane as an example. This has been taken to more broadly encompass performing any operation in the CDE without a mediating interface and Turing completeness. This is facilitated using the DXF object model. Since the DXF is an open standard, any compliant object model could be embedded into the ledger to interpret the data and perform analyses. Ruby, for example, has the “dxf-in-ruby” module and several others, Python has “ezdxf”, C# has “NetDXF”, C++ has “dxfliib”, and in many cases even use the common object model to link to your interface’s DXF object model. Alternatively, in the case of the highest point on the curve example, parse dotted lists with either assoc ID 10 (origin) or 11 (other points) to find the geometric data without understanding or interpreting the rest of the object.

The third is to embed the ledger directly into the CAD/BIM interface. Due to the nature of this research, the question is not particularly relevant. Where their target is to embed the ledger into Grasshopper, this research entirely decouples the ledger from all interfaces. The decoupling or agnosticism inherent of this research is dependent entirely on the use of an open standard data exchange format all

The fourth is having the full CAD/BIM environment embedded into a ledger outside of an interface similar to the centralised, IFC-based model proposed by (Pour Rahimian *et al.*, 2019). As the proposed ledger is interface-agnostic and the operations performed by the interface are low-level retrieval of positional data, the environment exists independently as much as in an interface. A less forgiving interpretation of (Theodoros Dounas, 2017)’s definition is a unified, lossless format which is a barrier faced by all CAD/BIM interoperability formats including IFC, however, it seems unlikely that was the intended definition.

The proposed model’s exploitation of the DXF open standard might be better described as facilitating the features of the levels proposed by (Theodoros Dounas, 2017) rather than demonstrating them, on some fronts. Nonetheless, the ledger is effectively a decentralised DXF with immutable history which means the ledger is 1) representative of the virtual environment 2) contains the data necessary to perform any operation that an interface may, assuming the function has access to the ledger data 3) is as much of an interface as any other intermediary interface such as AutoCAD which could reasonably be considered embedded into an interface and 4) is built on an open standard meaning that not only is it an interface in its own right, its operations can be verified by consensus using instances of the ledger and any interfacing

The problem with this type of system, however, is the qualities of distributed ledger technologies which remedy many personal identity-related conflicts and facilitate integrated project delivery can be exploited which may defeat the purpose of unified distributed ledger solutions. Much like social media, events and statements are recorded with little to no regard for context. They also interfere with professional relationships where it is no longer possible to subtly cover for a colleague and ownership of operation is no longer fuzzy; currently, ownership is negotiable or expressible as informally shared.

There is a clear interest in distributed ledger technologies in construction and it seems the UK government’s BIM ambitions will inevitably require a ledger-based solution. However, while such solutions may greatly improve communication and support some of the UK’s autonomous management ambitions, they fundamentally redefine work responsibility and are inevitably precursor exploitation by stakeholders as several responses to (Piroozfar *et al.*, 2019) lament.

5. Limitations / constraints

This paper use DXF and AutoCAD rather than IFC and any supporting interface for the illustrative convenience, though the principles are much the same. However, unlike using IFC, there is no prerequisite for using assemblies or blocks which means that entities are effectively unique rather than external references. There are two quick solutions, either create blocks in AutoCAD for the entities and use the “insert” command or use “copy” with previously created entities. This paper chose the “copy” method.

AutoCAD’s Reactor’s event system does not support on-mouse-move capturing.

6. Conclusion

Communication and trust play a significant role in all aspects of social and professional life. In construction, communication failures have been attributed 3% to 5% average project capital expenditure. Many of the problems whether stemming from social identities, exploiting finance release agreements or otherwise, are symptoms of poor data management and notary processes. The immutable and factual qualities of data in distributed ledgers make the technology an ideal if not the only practical solution to the barriers these problems raise. However, the same qualities which resolve existing problems introduce new social challenges and the inevitable data-driven exploits. The literature readily acknowledges these benefits of a distributed ledger for CAD/BIM but the progress largely appears to be at theory. This paper demonstrated a distributed ledger model for existing standard data exchange formats which fulfils many requirements indicated by the literature, including separation of CAD database and interface.

This process presented in this paper is a simple block reference method for creating decentralised common data environments from existing open standard data exchange formats. A rudimentary distributed ledger was developed to facilitate data management and the DXF CAD format was used to demonstrate the external reference-based method. The model demonstrates a decentralised OpenBIM format which leverages an existing open standard data exchange format. This is an important step towards implementing the features of the next generation of project lifecycle management like escrow-based payment systems. It also introduces the more significant but less tangible benefits that are said to be inherent of distributed ledgers.

7. References

- Back, A. (2002), "Hashcash - A Denial of Service Counter-Measure". <http://www.hashcash.org/hashcash.pdf> accessed: 22nd September 2020
- Bentov, I.Lee, C.Mizrahi, A. and Rosenfeld, M. (2014), "Proof of Activity: Extending Bitcoin's Proof of Work via Proof of Stake [Extended Abstract]". Vol. 42 No. 3 %J SIGMETRICS Perform. Eval. Rev., 34-37. doi: 10.1145/2695533.2695545
- Calefato, F. and Lanubile, F. 2010. Chapter 6 - Communication Media Selection for Remote Interaction of Ad Hoc Groups. *Advances in Computers*, Vol. 78, Elsevier, 2010, pp. 271-313. doi: [https://doi.org/10.1016/S0065-2458\(10\)78006-2](https://doi.org/10.1016/S0065-2458(10)78006-2)
- Cheung, S. O.Wong, W. K.Yiu, T. W. and Pang, H. Y. (2011), "Developing a trust inventory for construction contracting". *International Journal of Project Management*, Vol. 29 No. 2. 184- 196. doi: <https://doi.org/10.1016/j.ijproman.2010.02.007>
- Courtois, N. (2014), "On The Longest Chain Rule and Programmed Self-Destruction of Crypto Currencies".
- Das, M.Luo, H. and Cheng, J. C. P. (2020), "Securing interim payments in construction projects through a blockchain-based framework". *Automation in Construction*, Vol. 118. 103284. doi: <https://doi.org/10.1016/j.autcon.2020.103284>
- Dennis, A. and Kinney, S. (1998), "Testing Media Richness Theory in the New Media: The Effects of Cues, Feedback, and Task Equivocality". *Information Systems Research*, Vol. 9. 256-274. doi: 10.1287/isre.9.3.256
- Du, J.Zou, Z.Shi, Y. and Zhao, D. (2018), "Zero latency: Real-time synchronization of BIM data in virtual reality for collaborative decision-making". *Automation in Construction*, Vol. 85. 51-64. doi: <https://doi.org/10.1016/j.autcon.2017.10.009>
- Elghaish, F.Abrishami, S. and Hosseini, M. R. (2020), "Integrated project delivery with blockchain: An automated financial system". *Automation in Construction*, Vol. 114. 103182. doi: <https://doi.org/10.1016/j.autcon.2020.103182>
- Erri Pradeep, A. S.Yiu, K. T. W. and Amor, R. 2019. *Leveraging Blockchain Technology in a BIM Workflow: A Literature Review*. doi: <https://doi.org/10.1680/icsic.64669.371>
- Fan, X. and Chai, Q. 2018. *Roll-DPoS: A Randomized Delegated Proof of Stake Scheme for Scalable Blockchain-Based Internet of Things Systems*. ISBN: 978-1-4503-6093-7

- Gunawardena, C. N. (1995), "Social Presence Theory and Implications for Interaction and Collaborative Learning in Computer Conferences %J International Journal of Educational Telecommunications". Vol. 1 No. 2. 147-166.
- Haber, S. and Stornetta, W. S. (1991), "How to time-stamp a digital document". *Journal of Cryptology*, Vol. 3 No. 2. 99-111. doi: 10.1007/BF00196791
- Hunhevicz, J. J. and Hall, D. M. (2020), "Do you need a blockchain in construction? Use case categories and decision framework for DLT design options". *Advanced Engineering Informatics*, Vol. 45. 101094. doi: <https://doi.org/10.1016/j.aei.2020.101094>
- Li, Z. Barenji, A. V. and Huang, G. Q. (2018), "Toward a blockchain cloud manufacturing system as a peer to peer distributed network platform". *Robotics and Computer-Integrated Manufacturing*, Vol. 54. 133-144. doi: <https://doi.org/10.1016/j.rcim.2018.05.011>
- Malin, B. (2008), "k-Unlinkability: A privacy protection model for distributed data". *Data & Knowledge Engineering*, Vol. 64 No. 1. 294-311. doi: <https://doi.org/10.1016/j.datak.2007.06.016>
- Nakamoto, S. (2009), "Bitcoin: A Peer-to-Peer Electronic Cash System". *Cryptography Mailing list at <https://metzdowd.com>*. accessed: 22nd September 2020
- Noda, T. (2020), "Employee trust in management and mutual gains hypothesis in Japanese firms". *Journal of the Japanese and International Economies*, Vol. 55. 101062. doi: <https://doi.org/10.1016/j.jjie.2020.101062>
- Novacoin (2015), "Proof-of-stake". <https://github.com/novacoin-project/novacoin/wiki/Proofofstake>
- Oliver, S. (2019), "Communication and trust: rethinking the way construction industry professionals and software vendors utilise computer communication mediums". *Visualization in Engineering*, Vol. 7 No. 1. 1. doi: 10.1186/s40327-019-0068-y
- Peercoin (2020), "Proof-of-stake". <https://docs.peercoin.net/#/proof-of-stake>. accessed: 22nd September 2020
- Pettigrew, T. F. (2008), "Future directions for intergroup contact theory and research". *International Journal Intercultural Relations*, Vol. 32 No. 3. 187-199. doi: <https://doi.org/10.1016/j.ijintrel.2007.12.002>
- Piroozfar, P. Farr, E. R. P. Zadeh, A. H. M. Timoteo Inacio, S. Kilgallon, S. and Jin, R. (2019), "Facilitating Building Information Modelling (BIM) using Integrated Project Delivery (IPD): A UK perspective". *Journal of Building Engineering*, Vol. 26. 100907. doi: <https://doi.org/10.1016/j.jobbe.2019.100907>
- Pour Rahimian, F. Chavdarova, V. Oliver, S. Chamo, F. and Potseluyko Amobi, L. (2019), "OpenBIMTango integrated virtual showroom for offsite manufactured production of self-build housing". *Automation in Construction*, Vol. 102. 1-16. doi: <https://doi.org/10.1016/j.autcon.2019.02.009>
- Saltzer, J. H. and Schroeder, M. D. (1975), "The protection of information in computer systems". *Proceedings of the IEEE*, Vol. 63 No. 9. 1278-1308. doi: 10.1109/PROC.1975.9939
- Steinbrecher S., Köpsell S. (2003) Modelling Unlinkability. In: Dingledine R. (eds) Privacy Enhancing Technologies. PET 2003. Lecture Notes in Computer Science, vol 2760. Springer, Berlin, Heidelberg. https://doi.org/10.1007/978-3-540-40956-4_3
- Sund, T. Löf, C. Nadjm-Tehrani, S. and Asplund, M. (2020), "Blockchain-based event processing in supply chains—A case study at IKEA". *Robotics and Computer-Integrated Manufacturing*, Vol. 65. 101971. doi: <https://doi.org/10.1016/j.rcim.2020.101971>
- Theodoros Dounas, D. L. (2017), "A CAD-Blockchain Integration Strategy for Distributed Validated Digital Design". *eCAADe BIM Applications Conference* 36. http://papers.cumincad.org/data/works/att/ecaade2018_226.pdf
- Trope, Y. and Liberman, N. (2010), "Construal-level theory of psychological distance". *Psychological review*, Vol. 117 No. 2. 440-463. doi: 10.1037/a0018963
- Vasin, P (2014), "BlackCoin's Proof-of-Stake Protocol v2". <http://blackcoin.co/blackcoin-posprotocolv2-whitepaper.pdf> accessed: 22nd September 2020

Wu, G.Liu, C.Zhao, X. and Zuo, J. (2017), "Investigating the relationship between communication conflict interaction and project success among construction project teams". *International Journal of Project Management*, Vol. 35 No. 8. 1466-1482. doi: <https://doi.org/10.1016/j.ijproman.2017.08.006>

A PROPOSAL OF A SITE OBJECT LIBRARY FOR CONSTRUCTION WORKERS' SAFETY TRAINING USING BIM-BASED IMMERSIVE VIRTUAL REALITY

Vito Getuli*

University of Florence - Department of Architecture, Florence, Italy

*Corresponding author – e-mail address: vito.getuli@unifi.it

Pietro Capone, Alessandro Bruttini, Tommaso Sorbi

University of Florence – Department of Civil and Environmental Engineering, Florence, Italy

ABSTRACT: Workforce Health and Safety (HS) training in the construction sector has recently witnessed the growing adoption of immersive Virtual Reality technologies (VR) reaping the benefits of the enhanced workers' involvement and safety contents' transfer of on-site training while cancelling the related risks and costs.

However, despite the diffusion of Building Information Modeling (BIM) and of BIM tools for construction simulation and planning, most VR training experiences are still based on generic construction site environments and are not included in a comprehensive training program that takes into account and leverages project-specific information and contents comprised in BIM Site models.

For this reason, in previous work (Getuli, Capone and Bruttini, 2020) the authors proposed a prototype implementation protocol of BIM and VR for the planning, management and administration of three typologies of VR safety training (Layout, Activity and Emergency) via a game technology-based workflow encountering in the production of the VR training experiences a limitation in the lack of a standard categorization and informative requirements definition for construction site objects.

In order to address this issue, the present work proposes a BIM-based Site Object Library oriented to the production of VR safety training experiences as a result of a three-step process with the definition of: 1) Object list and categories from the analysis of construction sector's regulations, case studies and site scenarios' imagery; 2) Object requirements from the analysis of their real features (e.g. visual aspects, sounds, motion patterns); 3) Object Information Sheet for the inclusion of any site objects in the library.

The implementation and validation of the proposed Site Object Library is currently in progress for the production of BIM-Based VR safety training experiences on a case study project and will be discussed in future works.

KEYWORDS: Site Object Library, BIM, Health & Safety training, Construction workers, Virtual Reality, Game technology.

1. INTRODUCTION

In recent years the adoption of advanced visualization technologies, such as Virtual and Augmented Reality (VR/AR), in the AECO industry has increased for several purposes (e.g. design review, stakeholder's engagement, training, etc) during the whole project lifecycle, from early design iterations to construction and operation, but, despite promising outcomes, still struggles to gain momentum due to existing development gaps (Davila Delgado et al., 2020).

In this context, the adoption of immersive VR for workforce Health and Safety (HS) training represents one of the most interesting use-cases both for the academy and the industry because of the reported benefits in terms of safety contents' transfer related to an enhanced workers' involvement and of the reduction of risks and costs related to on-site training (Sacks, Perlman and Barak, 2013; Li et al., 2018).

The introduction of users in immersive virtual environments comprising the vivid and interactive reproductions of real building and site configuration for construction education and training produced interesting results enabled by a real-scale first-person space perception (Bashabsheh, Alzoubi and Ali, 2019; Castronovo et al. 2019)

The adoption VR-enabled systems for the visualization of the project information demonstrated to provide significant improvements in term of collaboration and information sharing among different stakeholders (Pour Rahimian, 2019). Interactive VR reproductions of site layout configurations in the different planned phases (Boton,

2018) and, moreover, of relevant construction activities placed in their expected site environments proved to be an effective tool for the evaluation of safety procedures and for the inclusion of the elicited workers' field knowledge in the H&S management process (Getuli et al., 2020).

Furthermore, concerning workers' safety training, document-based traditional training methods are overcome by VR-based methods and experiences due to the higher level of involvement and presence provided to the trainees (Perlman, Sacks and Barak, 2014). In this regard, the immersion in multi-user interactive VR environments have been proven highly effective in the training for complex tasks and construction site activities such as tower crane operation and oil and gas facilities' maintenance simulation (Guo et al., 2012; Hou et al., 2017).

Nonetheless, the diffusion of immersive VR for safety training is still limited to few early adopters mainly due to the existing implementation barriers related to the required specialistic know-how and to the poor integration with other established technologies and methodologies in the field.

For this reason, acknowledging Building Information Modeling (BIM) as the leading methodology and the common ground for the development of innovative applications, the authors already identified in previous works the opportunity to integrate BIM and game technology to foster VR safety training (Getuli et al., 2018; Getuli Capone and Bruttini, 2019). Moreover, in order to demonstrate a larger-scale feasibility of immersive VR for workers' safety training, an implementation protocol for planning, management and administration of HS contents with BIM and VR has been proposed and tested on a real case study project (Getuli, Capone and Bruttini, 2020). From the development and the results obtained in the aforementioned research work, it emerged among other issues the urgent need for an asset of resources that supported this implementation.

Therefore, this work aims to address this issue with a proposal of a BIM-based Site Object Library oriented to the production of VR safety training experiences. Since the study is currently ongoing, the results related to the problem analysis and to the library framework definition are here discussed, along with the proposition of a dedicated implementation support tool, leaving the discussion of the library implementation and validation to future works.

2. RESEARCH CONTEXT

The present work is to be considered as a branch of a broader authors' research effort regarding the development and implementation of a prototypical protocol for the integration of BIM and immersive VR technologies for construction workers' safety training as can be found in (Getuli, Capone and Bruttini, 2020). For this reason, in this paragraph a brief overview of the cited protocol is reported with reference to the issues that motivated this work (see Figure 1).

The proposed protocol aims to define a workflow for the implementation of workers' safety training sessions via immersive VR centred on the exploitation of the site model resulting from a BIM-based construction planning process for the representation of the workers' training scenario. It consists in a five-stepped cross-platform workflow which starts in a BIM authoring environment (1) with the acquisition of a multidisciplinary BIM model which is then enriched (2) with construction planning and H&S data oriented to the definition of site-specific workers' training scenarios (3). For this purpose, three training typologies, with the related aims and contents, have been defined (see Table 1) along with a decision support tool based on the identification of specific training milestones upon the construction schedule. Once modelled the training scenarios accordingly to the target training typology, the site's layout geometries and information are exported to a game-engine environment for their integration with additional multimedia contents and for the scripting of the necessary users' interactions (4). As final step of the process, the proper VR training experiences are eventually delivered according with the training schedule and administered to the workers via a supported immersive VR device (5).

The protocol was tested in a real case study project that comprised the production and administration of three VR training experiences and pointed out several implementation issues. Among these, it emerged the need for an organised asset of digital safety contents dedicated to the identified training typologies and optimized both for the BIM-based site modeling and the VR experience production (steps 2-4).

In particular, to facilitate the protocol's implementation the authors focused in the development of a Site Object Library with the following characteristics:

- Progressive objects classification system oriented to the scope of the different typologies of safety training and suitable for various site configurations, construction activities and emergency events occurrences.

- BIM-ready version for each site object whose representation in the BIM model of the site has relevance for a safety training purpose, including object's geometry and the related H&S data and workspaces. This version is intended for a BIM-authoring environment and is mostly replaced later in the game-engine environment with more suitable versions for their VR representation.
- VR-ready version for each site object intended to the production of realistic and interactive experiences able to foster the trainee involvement and therefore the training effectiveness and the safety contents' transfer. In this regard all the multimedia aspects contributing to the immersivity of the VR experience must be considered: graphic fidelity, audio contents and interactivity features.

All site objects included in the site layout modelled in the BIM authoring environment are usually present also in the delivered VR training scenario, whether they are directly transferred or replaced with more suitable VR versions. Nonetheless, depending on the objects or on the training typologies, site objects can present just a VR implementation due to their subsidiary function for immersivity and interactivity purposes related to the VR training experience (e.g. materials in storage areas, risks placeholders, PPE, manual tools, emergency equipment, etc).

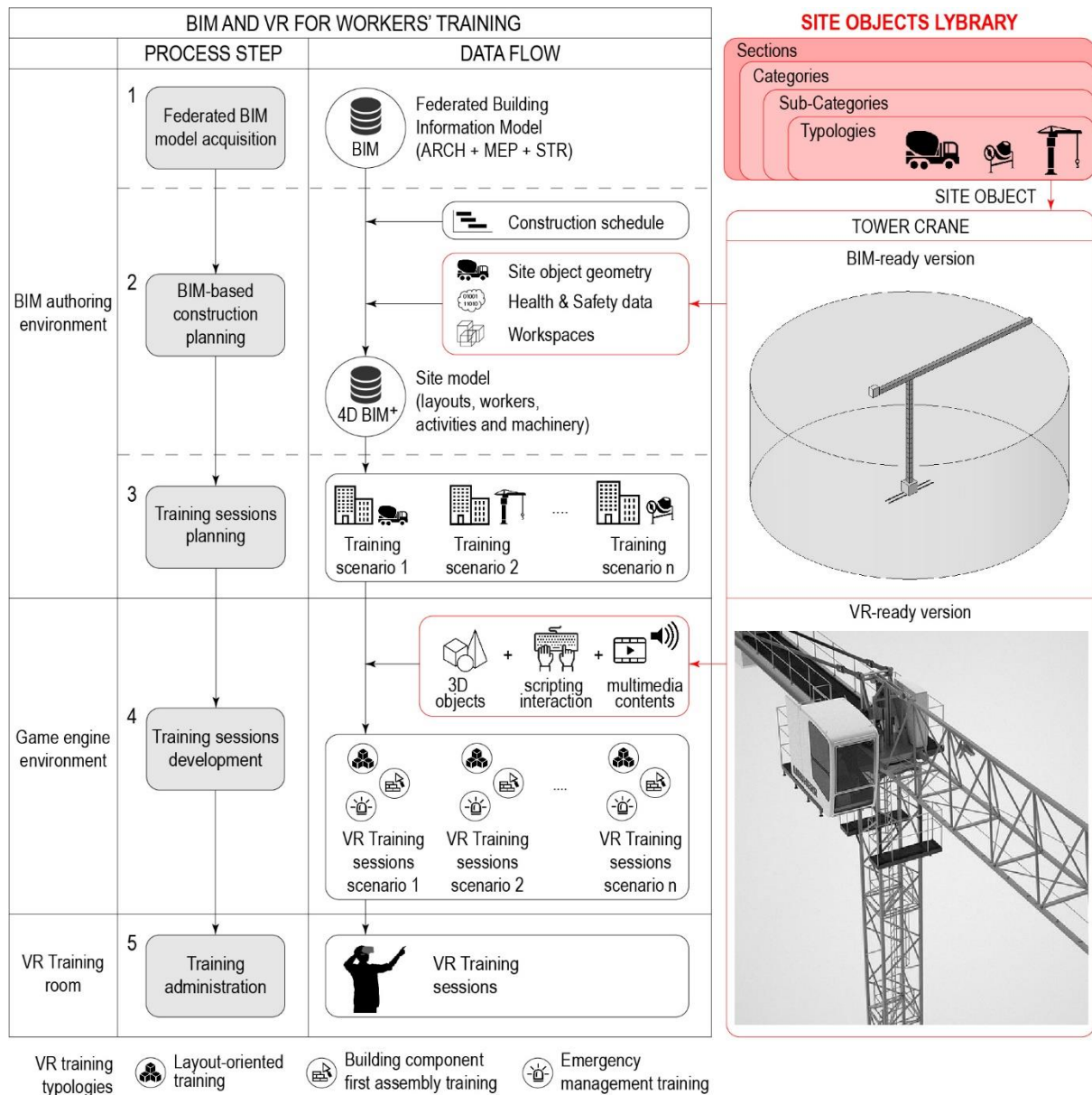


Fig. 1: Integration of the Site Objects Library in the proposed BIM-based implementation protocol for workers' safety training with Virtual Reality

Table 1: Typologies of safety training.

Training typology	Aims and contents
Layout-oriented training	The workers can experience the virtual reproduction of a forthcoming specific site layout configuration acknowledging the position, safety procedures and access and usage authorization for: site areas, equipment, facilities, plants, circulation paths, activity workspaces and specific risk zones.
Building component first assembly training	The workers can experience the virtual reproduction of a relevant construction activity (e.g. Building component first assembly occurrence) in the specific site layout in which it will take place, visualizing and interacting with the planned workspaces and learning about both the site and activities-related risks and the safety procedures to implement.
Emergency management training	The workers can experience the virtual reproduction of an emergency situation that could occur during a specific construction phase (and site layout/activities configuration), learning and implementing the planned emergency procedures, emergency equipment position and functioning, escapes route and rescue vehicles' paths. For the training purposes two typologies of emergency are distinguished: 1) Workers' illness or accident; 2) Fire.

3. RESEARCH OBJECTIVES AND METHOD

In order to provide a coherent framework for a library of virtual objects dedicated to the production of BIM-based immersive VR experiences for construction workers' safety training according to the aforementioned implementation protocol, the research focused on the following objectives:

- 1) *Site Objects' classification*: Identify and classify the objects required for the modeling and simulation of virtual reproductions of construction sites to be used for workers' safety training via immersive VR.
- 2) *Site Objects' requirements definition*: Define the objects' requirements in terms of geometry, information, graphics and interactivity features with reference to their uses; namely: worker's Health and Safety training, construction site BIM-based modeling and planning (4D) and construction site and activities simulation via immersive VR technologies.
- 3) *Site Objects' Information Sheet*: Design an information sheet common to all the objects' categories and serving as a library implementation support tool. In fact, all the relevant information identified for every object in the library are reported in the sheet allowing for a consistent object's choice and implementation in the construction site model dedicated for workers' training.
- 4) *Site Object Library's implementation and validation*: Implement the library with objects related to every identified category and according to the defined requirements. Validate the implemented objects with their adoption for the production of immersive VR safety training simulations based on the BIM model of the construction site.

The library implementation and validation are currently object of an on-going research and concerns the production of several immersive VR training experiences to be tested directly with the workers involved in the construction of the children's hospital "Stella Maris" in the city of Pisa (Italy). Therefore, leaving the detailed discussion of the related approach and results to future works, in the following steps is presented the method adopted for the library development (see Figure 2):

- 1) *Characterization of a generic construction site for workers' safety training purpose*: The first step in the development of the proposed site object library consisted in answering the following questions:
 - Which tangible objects, different from the building components, can be found in a construction site and are relevant for workers' safety training purposes? (equipment, scaffolding, fences, machinery, workers, etc.)
 - Which non-tangible objects could be relevant for workers' safety training purposes? (workspaces, site areas definitions, risks identification, etc.)
 - How could these objects be classified for their consistent implementation of BIM and VR site models for a generic construction project?

In order to address these questions, it has been conducted the analysis of different knowledge sources, namely: literature (case studies); construction site imagery and national (Italian) Health and Safety regulation about construction site and workers' training.

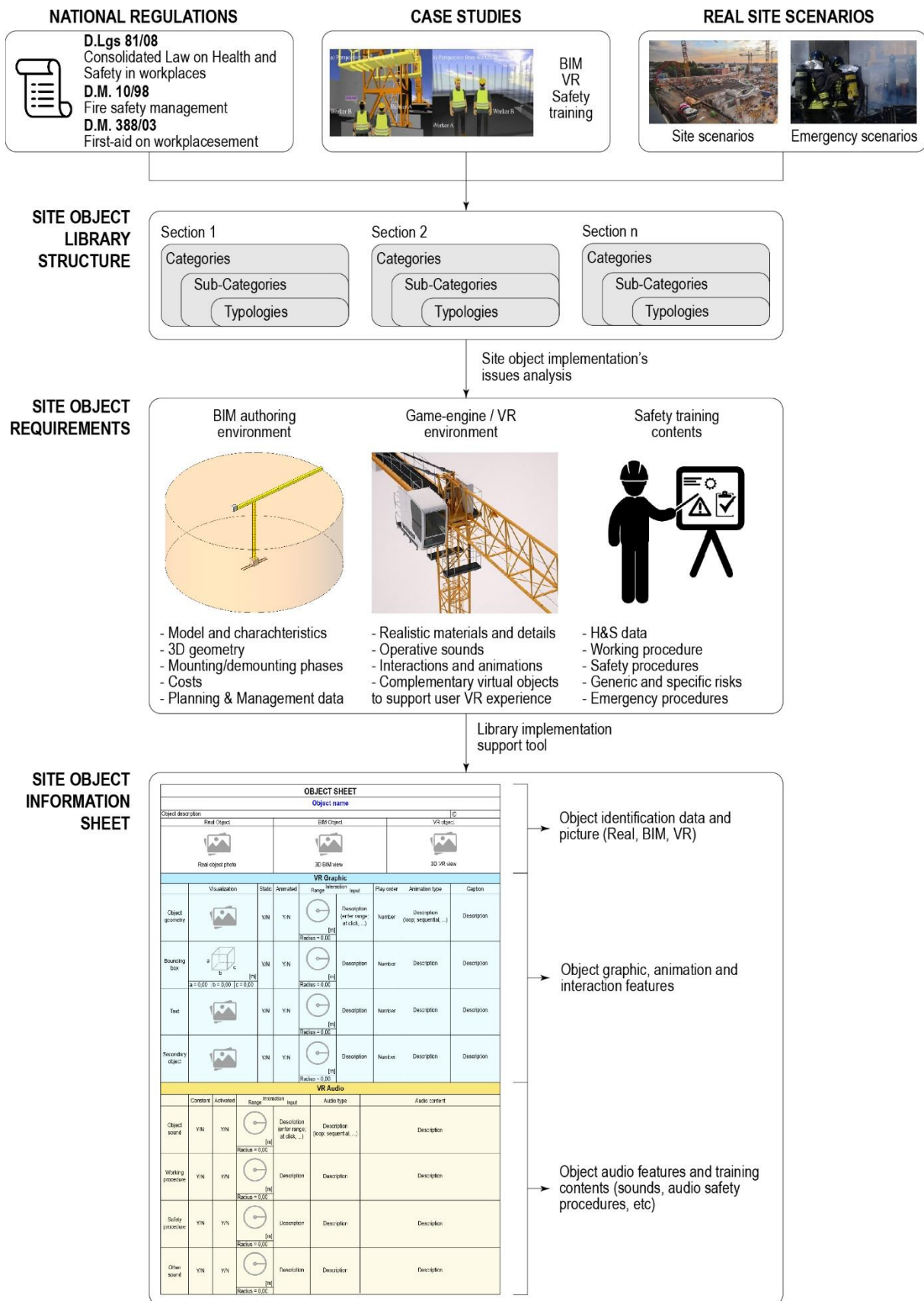


Fig. 2: Site Object Library development workflow

- 2) *BIM and VR site objects' requirements*: In order to define the objects' requirements in terms of geometry, information, graphics and interactivity features, the authors focused on their implementation processes in the BIM authoring environment (site planning) and in the game-engine environment (VR training experience production), keeping in mind the objects' purpose in term of transfer of H&S contents.
- 3) *Site objects' Information Sheet design*: After the identification of the objects' requirements, a further research effort regarded the design of a single-page sheet comprising all the relevant information of each object. Thereby the H&S managers using the library are provided with an effective implementation support tool, so that they could search and choose the most suitable object just going through their information sheets, before importing them in BIM or VR authoring environment.

4. SITE OBJECT LIBRARY FOR BIM-BASED WORKERS' SAFETY TRAINING WITH VIRTUAL REALITY

4.1 Structure of the Site Object Library

The results of the analysis conducted for the characterization of the general construction site (literature, case studies, national regulation) with the purpose of the production of workers' safety training-oriented contents, determined the division of the proposed Site Object Library into the following three main sections (see Fig. 3):

- 1) *Construction site layout and activities*: This section comprises all the tangible and non-tangible objects which can be identified in a construction site and are relevant for the description of its layout configuration and on-going activities. The objects classified under this section are used to represent in a virtual site model not only the physical components and equipment but also the workspaces and the risks related to the environment and construction activities. They allow the production of BIM site models and VR scenarios dedicated to "Layout-oriented" and "Building component first assembly" training typologies.
- 2) *Emergency management – Fire*: This section comprises all the objects which can be identified in case of fire on a construction site and are relevant for the emergency management training.
- 3) *Emergency management – Illness*: This section comprises all the objects which can be identified in case of workers' illness or accident on a construction site and are relevant for the emergency management training.

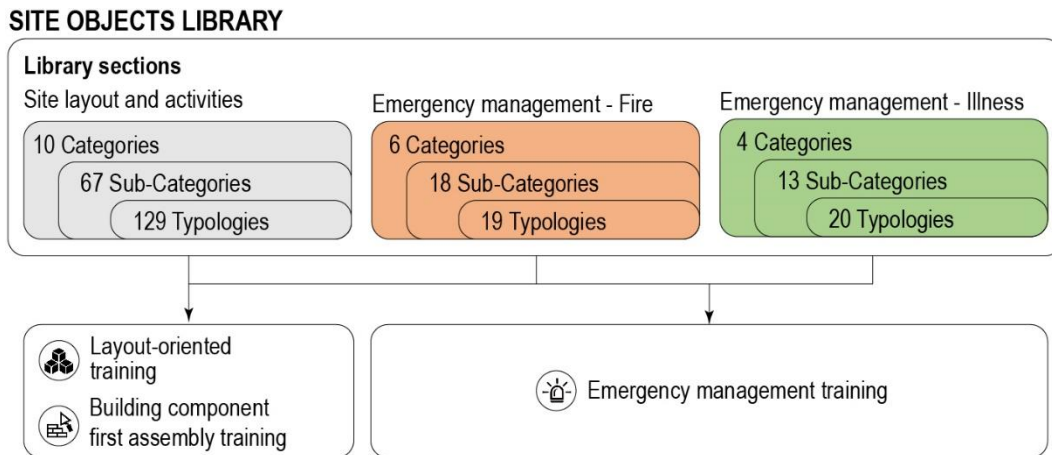


Fig. 3: Structure of the Site Object Library

Each section presents a three-level progressive classification for the objects based on categories, sub-categories and typologies. The "Emergency management" sections of the library dedicated to both Fire and Illness emergency training are currently in progress and will be discussed in future works. The object classification of the "Site layout and activities" section is reported in the following Table 2-3.

Table 2: Site Object Library: Construction site layout and activities modeling (continues).

		Real site	BIM	VR	
Workspaces	Construction site		X	X	
	Main entrance	Main gate guard house	X	X	
		Access barrier	X	X	
	Materials staging areas	Mechanical materials area	X	X	
		Instrumentation materials area	X	X	
		Garbage area	X	X	
		Excavation ground area	X	X	
	Machine areas	Fabrication area	Iron	X	X
			Wood	X	X
			Concrete	X	X
	Working area	Dig			
	Parking	Worker	X	X	
Site construction machines		X	X		
Warehouses	Office		X	X	
	Sanitary facilities		X	X	
	Portable toilet		X	X	
	Changing facilities		X	X	
	Storage of personal protective equipment		X	X	
	Perishable materials		X	X	
	Refectory		X	X	
	Dormitory		X	X	
	Medical room		X	X	
	Waste container		X	X	
Worker	Workman			X	
	Engineer			X	
	Electricity		X	X	
Service lines	Grounding set				
	Water supply	Service water			
		Sewage			
Gas line		X	X		
Preparations	Fences for construction site	Polyethylene orange net	X	X	
		Stand alone panel	X	X	
		Hiding fence	X	X	
		Road barriers		X	
		Concrete road barriers	X	X	
	Parapet		X	X	
	Scaffolding		X	X	
	Wheeled tower		X	X	
	Forklift		X	X	
	Construction site elevator		X	X	
Viability	Driveway entrance		X	X	
			X	X	
			X	X	
			X	X	
	Driveway	Internal	X	X	
		External	X	X	
	Walkway	Internal			
External					
Risk identity	High-altitude fall			X	
	Slipping			X	
	Opening in the floor			X	
	Material falling from above			X	
	Interaction with other works			X	
	Risk of burning			X	
	Risk of electrocution			X	
Site construction machines	Digging and loading	Excavator	X	X	
		Dredge			
		Loader	X	X	
	Heavy earth moving	Transport	Dumper		
			Lorry	X	X
		Bulldozer			
	Digging and transport	Trailblazer			
		Leveler			
		Telehandler			

Table 3: Site Object Library: Construction site layout and activities modeling.

		Real site	BIM	VR	
Site construction machines	Lifting and material handling machinery	Crane	Jib crane for scaffolding		
			Column slewing jib		
			Bridge crane		
			Gantry crane		
			Tower crane	X	X
	Concrete machine		Batching plant	X	X
			Concrete mixer truck	X	X
			Concrete mixer	X	X
			Truck concrete pump	X	X
		Forklift			
	Truck	X	X		
	Truck crane				
	Bobcat				
Various		Red speaker		X	
		Private cars		X	
		Van	X	X	
		Bag of cement		X	
		Block of cement		X	
		Cable reel		X	
		Pallet		X	
		Worktable		X	
		Ground aggregation		X	
		Text - Score		X	
		Text - Input		X	
	Poster advertising	Construction site poster			
Prohibition		No access for unauthorised person		X	
		Smoking and naked flames forbidden		X	
		Work in progress			
		Do not extinguish with water			
		Not drinkable			
Warning		Do not remove the emergency devices and protections		X	
		Corrosive material			
		Toxic material			
		Explosive material			
		High temperature			
		Drop			
		Opening on the ground			
		Oxidant material			
		Overhead load		X	
		Danger:electricity			
		Danger: digging		X	
		Work in progress			
		High-altitude fall material			
		Obstacles			
		Industrial vehicles			
		Scaffolding under construction			
		Vehicles exit		X	
Mandatory		Wear respiratory		X	
		Wear ear protection		X	
		Wear safety helmet		X	
	Wear safety shoes		X		
	Wear safety gloves		X		
	Wear safety overall		X		
	Wear safety harness		X		
	Wear eye protection		X		
	Wear face protection		X		
	Pedestrians on right				
Safety	Check ropes and chains				
	Vehicle at walking pace				
	See related Library section				
	See related Library section				
	See related Library section				
Signs	Sign for marking obstacles				
	Sign for marking dangerous locations				
	Sign for marking traffic routes				

4.2 Requirements of the Site Objects (BIM vs VR)

From the implementation of the cited BIM-based protocol for the development and administration of VR experiences for workers' safety training and from the analysis of similar applications in case studies, real site scenarios and national health and safety regulation, emerged that the virtual representation of a site object has the following different requirements depending of the purpose and the environment for which they are intended to be used.

4.2.1 BIM Site object

BIM site objects commonly used for the construction site planning process have different graphical and informative development levels (LOD-LOI) set depending on the project phase and requirements. In order to leverage the site layouts resulting from this process for the development of site-specific VR safety training scenarios, the graphical detail of the site objects should be limited in order not to affect the file performance in the selected BIM authoring platform, considering moreover that they are mostly replaced with more detailed objects in the VR development environment for immersivity purposes. Nonetheless, is crucial that the information regarding the following safety training aspects is added to the site model via dedicated objects or customized parameters: workspace and paths, risks evaluation results and placeholders, workers' positions, working and safety procedures. This information serves then for the development and customization of the VR objects' features: multimedia contents (audio/video), animation, interaction.

4.2.2 VR Site object

The production of immersive VR experience for workers' safety training based on site-specific scenarios exported from BIM models involves the replacement of the most part of the implemented site objects with their dedicated VR-oriented counterparts. According to the exported safety training-related contents cited above, the VR site objects are in fact customized in terms of audio, graphic and interactivity features to enhance the experience realism and immersivity and therefore to improve the trainee involvement and the safety contents transfer. In this regard, the identified features which characterizes a VR-oriented site objects can be distinguished for Graphic and Audio contents as reported below (see also Fig. 4):

- VR Graphic: The visualization of the site object in the VR environment comprises 4 aspects that exceed the BIM object capabilities:
 - *object geometry* with an appropriate level of detail and realism depending on the selected VR technology,
 - *object tridimensional bounding box*
 - possible additional *text information* (e.g. labels with identification references, etc)
 - *secondary objects* for safety training purposes (e.g. virtual object for training supports such as direction arrows, interaction placeholders, etc).
















Depending on the training purposes and object characteristics, each cited aspect can be visualized with graphic elements which are static, animated or both. In case of animations, they can be activated within a certain *range* or in response of an user *input* in the VR environment and they can be presented in various *types* (e.g loop, sequential, etc) and in *ordered* combinations with other animations.

- VR Audio: The delivery of appropriate audio contents adds depth to the VR experience and strongly contribute to the training contents transfer in several ways. Considering the immersivity aspect of the VR experience, specific sound related to the site objects, construction activities and even the background sound of the construction site, can raise the realism of the experience and the involvement of the trainee if carefully controlled in order not to be too distracting for the training purposes. Nonetheless, the most important aspects regarding the audio features consists in the chance the offer to deliver training contents related to *working procedures*, *safety procedure* and interaction-related sounds (e.g. training notifications, objects activations etc). The mentioned procedures can be implemented on the scripted instructions included in the BIM version of the site object with dedicated voice recording or directly "read" from a speech synthesizer. As discussed above for the graphical animations, also the audio contents can be presented in different types (e.g. loop, sequential, etc), can be constant or activated within a certain *range* or in response of an user *input* in the VR environment.

4.3 Site Object Information Sheet

The following Site Object Information Sheet (Fig. 4) has been designed accordingly to the requirements identified above and in order to provide an operative tool which could both facilitate the implementation of the site objects

in the proposed library and drive and support the choices of the H&S manager during the production of the safety training experiences both in the BIM and VR environments. The proposed single-page sheet comprises all the relevant site object data in three sections, namely: *Object identification*, *VR Graphic* and *VR Audio*. Since the characteristics of the BIM version of the site objects is more limited and dependent on the safety contents which have to be transferred in the VR experience, the sheet focuses mainly on the VR graphical and audio aspects related to the requirements discussed in the previous paragraph and leaves the BIM information to the object representation in the top section (Object identification).

SITE OBJECT SHEET									
Site object name									
Object description									ID
Real Object			BIM Object			VR object			
									
Real object photo			3D BIM view			3D VR view			
VR Graphic									
	Visualization	Static	Animated	Range	Interaction	Input	Play order	Animation type	Caption
Object geometry		Y/N	Y/N	 [m] Radius = 0,00	Description (enter range; at click, ...)	Number		Description (loop; sequential, ...)	Description
Bounding box	 a = 0,00 b = 0,00 c = 0,00	Y/N	Y/N	 [m] Radius = 0,00	Description	Number		Description	Description
Text		Y/N	Y/N	 [m] Radius = 0,00	Description	Number		Description	Description
Secondary object		Y/N	Y/N	 [m] Radius = 0,00	Description	Number		Description	Description
VR Audio									
	Constant	Activated	Range	Interaction	Input	Audio type	Audio content		
Object sound	Y/N	Y/N	 [m] Radius = 0,00	Description (enter range; at click, ...)		Description (loop; sequential, ...)	Description		
Working procedure	Y/N	Y/N	 [m] Radius = 0,00	Description		Description	Description		
Safety procedure	Y/N	Y/N	 [m] Radius = 0,00	Description		Description	Description		
Other sound	Y/N	Y/N	 [m] Radius = 0,00	Description		Description	Description		

Object identification
- Name
- Brief description
- ID
- Pictures

Object VR graphic
Visualization, animation and interaction features:
- Object geometry
- Bounding box
- Text information
- Secondary object

Object VR audio
Characteristics, interaction and contents for:
- Object sound
- Working procedure
- Safety procedure
- Other sound

Fig. 4: Site Object Information Sheet (blank fac-simile)

5. CONCLUSIONS

At this development stage, the research achieved its first three objectives with the proposition of a Site Object Library for the BIM-based production of VR experiences for workers' safety training according to a prototypical dedicated protocol. In fact:

- 1) Site objects that are relevant for H&S purposes have been identified and classified within a three-level framework comprising three sections with three progressive sub-categories for a total of 168 objects' typologies;
- 2) The information requirements for the virtual site objects for safety training purposes have been outlined considering both the BIM and VR contents' development environments comprised in the safety training protocol, stressing the importance of the multimedia and interaction features that they should provide for their effectiveness during the training experiences.
- 3) A Site Object Information Sheet has been designed as an operative support tool for the library implementation and in order to support H&S managers during the VR training scenarios and contents' production.

The next steps of the research, that is currently focused on the production of VR safety training experiences for the workers involved in the construction of the new children's hospital "Stella Maris" in the city of Pisa (Italy), will concern the full library implementation, along with all the objects identified at this stage and its use and validation for the cited case study project. Therefore, the analysis and the discussion of the related results will be reported in a future comprehensive work.

ACKNOWLEDGEMENTS

The authors acknowledge the contribution of Eng. Clara Barsotti and Eng. Valentina Fornasari who collaborated to the development of the present research as part of their master thesis in Building Engineering at the University of Florence.

REFERENCES

- Bashabsheh A. K., Alzoubi H. H. and Ali M. Z. (2019), "The application of virtual reality technology in architectural pedagogy for building constructions", *Alexandria Engineering Journal*, Vol. 58, pp. 713-723, available at: <https://doi.org/10.1016/j.aej.2019.06.002>.
- Boton C. (2018), "Supporting constructability analysis meetings with Immersive Virtual Reality-based collaborative BIM 4D simulation", *Automation in Construction*, Vol. 96, pp. 1-15, available at: <https://doi.org/10.1016/j.autcon.2018.08.020>.
- Castronovo F., Nikolic D., Mastrolembo Ventura S., Akhavian R., Gaedicke C. and Yilmaz S. (2019), "Design and development of a virtual reality educational game for architectural and construction reviews", *Proceeding of 126th ASEE American Society for Engineering Education Annual conference & Exposition*, Tampa FL.
- Davila Delgado J. M., Oyedele L., Demian P. and Beach T. (2020), "A research agenda for augmented and virtual reality in architecture, engineering and construction", *Advanced Engineering Informatics*, Vol. 45, 101122, available at: <https://doi.org/10.1016/j.aei.2020.101122>
- Getuli V., Giusti T., Capone P., Sorbi T. and Bruttini A. (2018), "A Project Framework to Introduce Virtual Reality in construction Health and Safety", *AlmaDL Journals, in_bo, New Frontiers of Construction Management Workshop*, Vol. 09 No. 13, pp. 166-175.
- Getuli V., Capone P. and Bruttini A. (2019), "Game technology and Building information Modelling for the adoption of Virtual Reality in construction safety training: a prototype protocol", *Proceedings of the 36th CIB W78 Conference - Advances in ICT in Design, Construction and Management in Architecture, Engineering, Construction and Operations (AEEO) (Newcastle, UK)*, Newcastle (UK), pp. 594-607
- Getuli V., Capone P. and Bruttini A. (2020), "Planning, management and administration of HS contents with BIM and VR in construction: an implementation protocol", *Engineering, Construction and Architectural Management*,

ahead-of-print, available at: <https://doi.org/10.1108/ECAM-11-2019-0647>.

Getuli V., Capone P., Bruttini A. and Isaac S. (2020), "BIM-based immersive Virtual Reality for construction workspace planning: A safety-oriented approach", *Automation in Construction*, Vol. 114, 103160, available at: <https://doi.org/10.1016/j.autcon.2020.103160>.

Guo H., Li H., Chan G. and Skitmore M. (2012), "Using game technologies to improve the safety of construction plant operations", *Accident Analysis and Prevention*, Vol. 48, pp. 204-213, available at: <https://doi.org/10.1016/j.aap.2011.06.002>.

Hou L., Chi H., Tarng W., Chai J. and Panuwatwanich K. (2017), "A framework of innovative learning for skill development in complex operational tasks", *Automation in Construction*, Vol. 83, pp. 29-40, available at: <http://dx.doi.org/10.1016/j.autcon.2017.07.001>.

Li X., Yi W., Chi H., Wang X. and Chan A. P. C. (2018), "A critical review of virtual and augmented reality (VR/AR) applications in construction safety", *Automation in Construction*, Vol. 86, pp. 150-162, available at: <https://doi.org/10.1016/j.autcon.2017.11.003>.

Pour Rahimian F., Chavdarova V., Oliver S. and Chamo F. (2019), "OpenBIM-Tango integrated virtual showroom for offsite manufactured production of self-build housing", *Automation in Construction*, Vol. 102, pp. 1-16, doi: 10.1016/j.autcon.2019.02.009.

Sacks R., Perlman A. and Barak R. (2013), "Construction safety training using immersive virtual reality", *Construction Management and Economics*, Vol. 31, No. 9, pp. 1005-1017, available at: <https://doi.org/10.1080/01446193.2013.828844>.

AUTOMATED PROGRESS MONITORING VIA SCHEDULE UPDATING BY USING CONVOLUTIONAL NEURAL NETWORKS AND A SPECIALIZED LABELED DATASET FOR CONSTRUCTION COMPONENTS

Reza Hedayat Nejad

Auckland University of Technology, New Zealand

Ali Ghaffarianhoseini

Auckland University of Technology, New Zealand

Amirhosein Ghaffarianhoseini

Auckland University of Technology, New Zealand

ABSTRACT: Computer vision has recently gained a lot of popularity in the construction industry by simplifying classification, detection, and segmentation tasks. The majority of studies in the construction field have been focused on the application of convolutional networks in damage detection, monitoring and safety. However, only a few studies have evaluated the importance of automated progress monitoring by the use of automatic task detection. One of the benefits of deep learning, which has been successfully tested, is training a model for task classification and creating semantic content learning. By using this ability, images can be labeled and translated into tasks that are understandable, comparable and measurable for a machine. This paper proposes a novel method of automatically updating schedules in construction projects by accessing the schedules, and comparing the WBS with real progress in on the site through convolutional neural networks. To reach this goal, the first step is to make a dedicated and comprehensive dataset of construction elements and label them. This dataset, called ConsNet, plays the role of ImageNet, but for the construction industry. This paper shows, that the proposed method can define an automatic progress monitoring system with an accuracy of up to 96%. In addition the introduction of ConsNet opens up new horizons for future construction works built upon the basis of deep learning. Additionally, the aforementioned dataset not only increases computing speed by transferring learning, but also by significantly reducing overfitting issues normally occurring due to the small size of ad-hoc datasets..

KEYWORDS: computer vision; construction projects; convolution network; 4D BIM; automated progress monitoring, ConsNet; schedule update; Inception v4.

1. INTRODUCTION

The ability to update schedules in construction projects is a vital tool for project managers in order to evaluate the status of the projects in terms of costs, assets and delays. A realistic schedule is on its own considered an indispensable part of automated progress monitoring [1]. The majority of delays in such projects are attributed to unrealistic scheduling or the lack of control of schedules. Traditional monitoring methods prompt the project managers to consume 30%–49% of their time on gathering, visualizing, and analyzing data to get an overall view of the project status [2]. Despite these efforts, the expense of progress monitoring of construction sites is estimated to occupy approximately 1% of the project's gross budget [3]. Currently, manual updating happens to be the norm when tracking progress on construction sites in which the discrepancies, between as-built and as-planned data, are delineated by supervisors, and shared with the managers [4]. The process of manual progress updating is labor-intensive, significantly time-consuming and prone to be biased [5]. In recent years, lots of efforts have been focused on the automatization of progress monitoring and schedule updating via the application of technologies like surveillance cameras [6], cloud point [7], 3D scanners [8], UAV [9] and LiDAR.

The main approach to automatic construction progress tracking, lies in the automation of object recognition by the alignment of site images with the BIM-based object recognition [10]. The vision-based techniques, which use imaging devices such as sensors and scanners, are now emerging as the most effective tool for inspection and monitoring [11]. This technology has garnered much attention due to the ability of processing big data and visual information at a lower cost, and with higher accuracy [12]. The maturity of deep learning algorithms especially CNN (Convolution Neural Network), impels scholars to broadly deploy them for construction issues such as object detection and safety.

However, there are still hurdles preventing a wider utilization of this computer vision in construction projects. One of the vulnerabilities is the need for a huge dataset of localized labeled data [13]. Currently, a large dataset of labeled construction images is not available. Data has to be gathered and labeled manually, a tedious and

time-consuming process. Making a dedicated dataset, as well as automatically generating these labels, can drastically reduce the preparation efforts for the training and improvement of such a model [9].

The first objective of this paper is to introduce the concept of a specialized constructional dataset. Although the application of CNNs is being tested for ad-hoc construction problems such as damage detection, change detection, and safety monitoring, scholars normally use undedicated image datasets to train their models. Most of them suffer from a lack of containing enough images in their dataset and thus face overfitting. Besides, images for such dataset are limited in number and normally gathered by non-standard methods using search engines for unique problem solution, such as detecting cracks. Those databases are normally unusable for other purposes. A specialized dataset that supports most of the construction tasks and elements can bring huge benefits to construction projects as an open-source and extendable tool for related works.

The second objective of this paper is to examine automate progress monitoring by automatically updating the schedule in the 4D BIM equipped projects with the application of deep learning methods like convolutional neural networks. The first step is to make a huge dataset of construction elements and label them. Using such a specialized dataset not only avoids overfitting, but also increases accuracy, and can be later used for Transfer Learning.

2. LITERATURE REVIEW

Many efforts have been and are made on the escalating level of automation in projects, and one of the popular methods used is by comparing the current status of a project with an as-planned model. For example, many papers have been focused on the fusion of BIM, photogrammetric and point-cloud data. Authors in [14] have used fixed as well as UAV cameras to generate point cloud images (as-built), and compare them with 4D BIM (as-planned). Similarly, Braun and Bormann [9] discuss an automated labeling method for photogrammetric point-cloud images and BIM data. Dimitrov and Golparvar-Fard [15] propose a method for material detection by training a deep learning classifier. Another paper discusses an automated monitoring method for indoor drywall tasks [16]. Authors in [17] evaluate an automated method for updating schedules and the progress of IFC-based BIM by employing information available for the project's elements. Deep learning techniques have been successfully tested for the recognition of constructional machines with 96% precision. This study verified the effectiveness of CNN in the detection of constructional machines [18].

A technique for updating schedule was discussed in a paper where point-cloud data produced by a laser scanner (as-built) is compared with a 4D model (as-planned) and the result is embedded in the BIM schedule [4]. However, the proposed model is limited by the necessity of using a costly laser scanner. Besides, 3D registration of model and localization used manual processes. Similarly, IFC-based BIM is exploited for proposing a colored-code method by measuring the progress ratio of as-built images and updating the BIM internal schedule [17]. The accuracy of the model, nevertheless, was vulnerable when the schedule or 3D model was too detailed.

For the task of progress monitoring, authors in [9] utilized transfer learning for material image classification. In this research, the SVM (Support vector machine) algorithm was used as a classifier. In novel research, the progress is monitored by automatically detecting spatial changes at the site [19]. Subsequently, the changes are quantified and the completed work is calculated in an unsupervised environment.

3. A COMPREHENSIVE CONSTRUCTIONAL DATASET (CONSNET)

ConsNet is a proposed dataset project for the construction industry, aiming to cover almost all construction projects and components for highly detailed engineering projects in the form of an image-dataset. Datasets are back-bones and training feed for the machine learning models. In computer vision, the datasets are mostly digital sources like images, point-clouds and videos gathered either from free available datasets like ImageNet or researchers' image acquisition techniques. Making a robust dataset for a CNN model is a determining key for reaching a high level of precision.

In most of the academic projects, the proprietary datasets are either not publicly available or they focus on a specific niche that is impractical for use in future projects. On the other hand, openly available datasets like

ImageNet, typically cover general fields like plants, animals, and people that scarcely embrace detailed engineering components. In terms of deep learning for specific cases that need detailed training models researchers need to manually gather their own datasets either by using search engines or self-captioning. These kinds of datasets are normally very small and suffer from a resolution threshold and overfitting, although some of these issues can later be compensated for by transfer learning method [9].



Figure 1. A holistic construction database for deep learning projects

Overfitting occurs when the model perfectly learns a training set, but shows poor performance on a validation or a test set. To cope with a small database, a model with the ImageNet dataset has been trained on base of fine-tuning method for a smaller dataset [18]. Similarly, a fine-tuned model was used for the surface detection model on Con4 instead of fully connected layers with a smaller dataset of construction components like bricks or concrete [20].

To bridge this gap, ConsNet provides a dedicated dataset that targets the hierarchical relationship of all the components in the construction industry. As an ambitious goal, the ConsNet project entails four steps that should be accomplished by 2022. In the first step the images for residential building projects in 50 subsets in 10 categories are provided by the methods that are elaborated in the next section. **Figure 2** shows ConsNet completion processes. AUT University along with global partners gather around three million images from different projects covering all subsets that have been listed in this paper. In the last step, participants are supposed to gather more specialized images used for inspection, monitoring and facility management. We aim to have 1,000 to 10,000 images per subset and it is feasible through augmentation, multi-language searching methods and task-sharing.

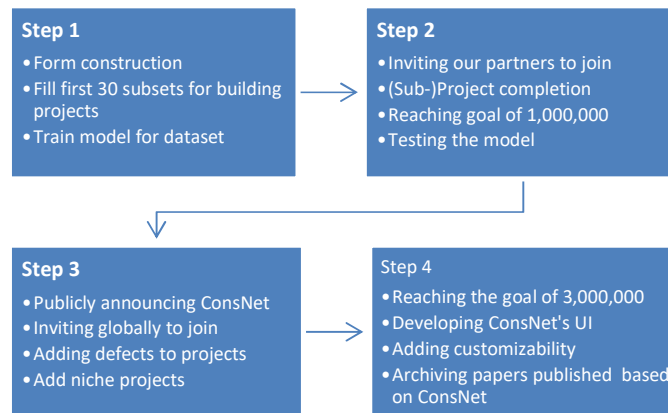


Figure 2. ConsNet's completion processes by 2022

3.1 Properties

The ConsNet is intended to be a freely available and customizable dataset for educational and research purposes. ConsNet at its completion would be a collection of hierarchical images that cover almost all types of projects in the construction industry such as dams, piping, tunnels, highways and buildings. Although in the preliminary step the dataset covers components for the residential buildings, the final version encompasses almost all varieties of the construction categories ranging from heavy infrastructures to housing projects.

Table 1 is an estimation of the number of pictures for 60 main classes and 140 sub-classes with a reservoir of four million medium and large-size images.

Table 1 ConsNet structure of building category

Classes	Classes	Sub-C.	#Elements	#Images
Constructional Material	10	50	210	500000
Constructional Components	10	40	120	1000000
Constructional machineries	4	15	20	500000
Constructional tasks	10	10	50	1000000
Safety equipment	5	10	35	500000
Defects	30	15	60	500000
Total	69	140	485	4000000

3.1.1 Interconnection

ConsNet’s structures are built upon the hierarchical interrelationships of tasks and components in a project. Five construction parameters, including tools, materials, machinery, safety, defects and extras are connected to several tasks for each project, and these connections demonstrate the hierarchical array of elements. **Figure 3** shows the project-based hierarchical structure of ConsNet. Tasks in the construction projects are categorized on the basis of different phases like the excavation phase, foundation phase, welding phase and so on. For each task, correspondingly, there are a number of components. There might also be some extra components connected to each task like personal workers’ apparel or temporary structures that are erected for some specific tasks such as scaffolding.

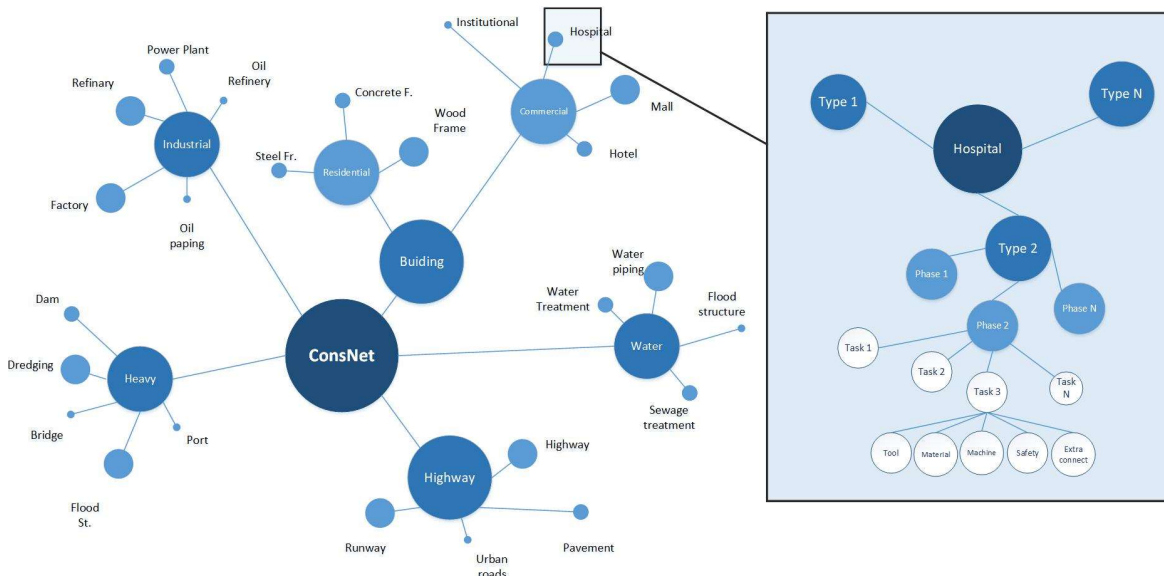


Figure 3. Hierarchical project-based structure of ConsNet on completion

ConsNet encompasses huge collections of labeled images that cover almost all the aforementioned items. There is also another hierarchical structure for each component showing their interconnection relationships. For material components, for example, there is a relationship chart showing the interconnection of material classes, material types and material items with a unique item number that later is used for generating a task matrix. An online API later provides the users with a customizable ConsNet dataset on the base of project type, location and image count

and resolution.

3.1.2 Image Acquisition and Augmentation

For ConsNet the images should be gathered from two distinct sources. Firstly, private archives of companies and volunteers, and secondly web-based images such as Google images, which are downloaded through ConsNet dedicated API. For the small subsets or highly detailed tasks or components that haven't met expectations, augmentation is applied. The data augmentations increase the size of the training dataset up to 100 times [21]. In some cases, especially with very detailed fields, gathering a big dataset of images is impossible. In that case a minor alteration and augmentation can be a solution [22].

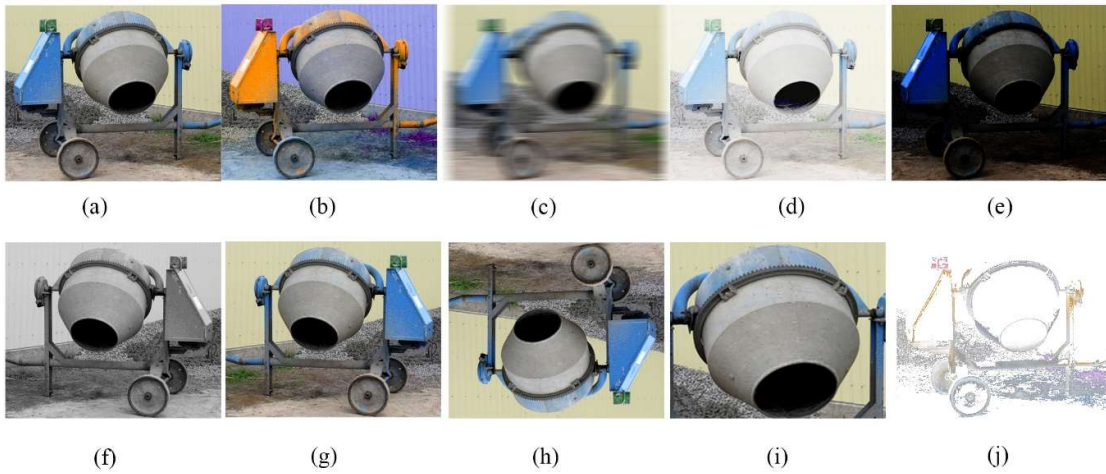


Figure 4. Augmentation samples for concrete mixer (a) original image, (b) color adjusting, (c) motion blur, (d) contrasting higher brightness, (e) lower contrast, (f) grayscale, (g) horizontally rotate, (h) vertical rotate, (i) 100% zoomed (j) edging

3.1.3 Labeling

The main advantage of ConsNet is providing labeled images for the users. Millions of labels can be provided by task-sharing, and international volunteers who would like to participate in this project. Infrastructures like AWT (Amazon Mechanical Turk) can be widely utilized to assign tasks, manage the users and monitor the progress [23] [24].

4. AUTOMATED SCHEDULE UPDATING THROUGH CNN

This process has two distinct sections. The first section exports the schedules from different sources into a reasoning algorithm. The latter section collects as-built images and forwards them to a convolutional network for object and task detection. The result of the two sections is compared and the output reveals project status, delay and subsequently updates the schedule.

4.1 Section One: Schedule reasoning

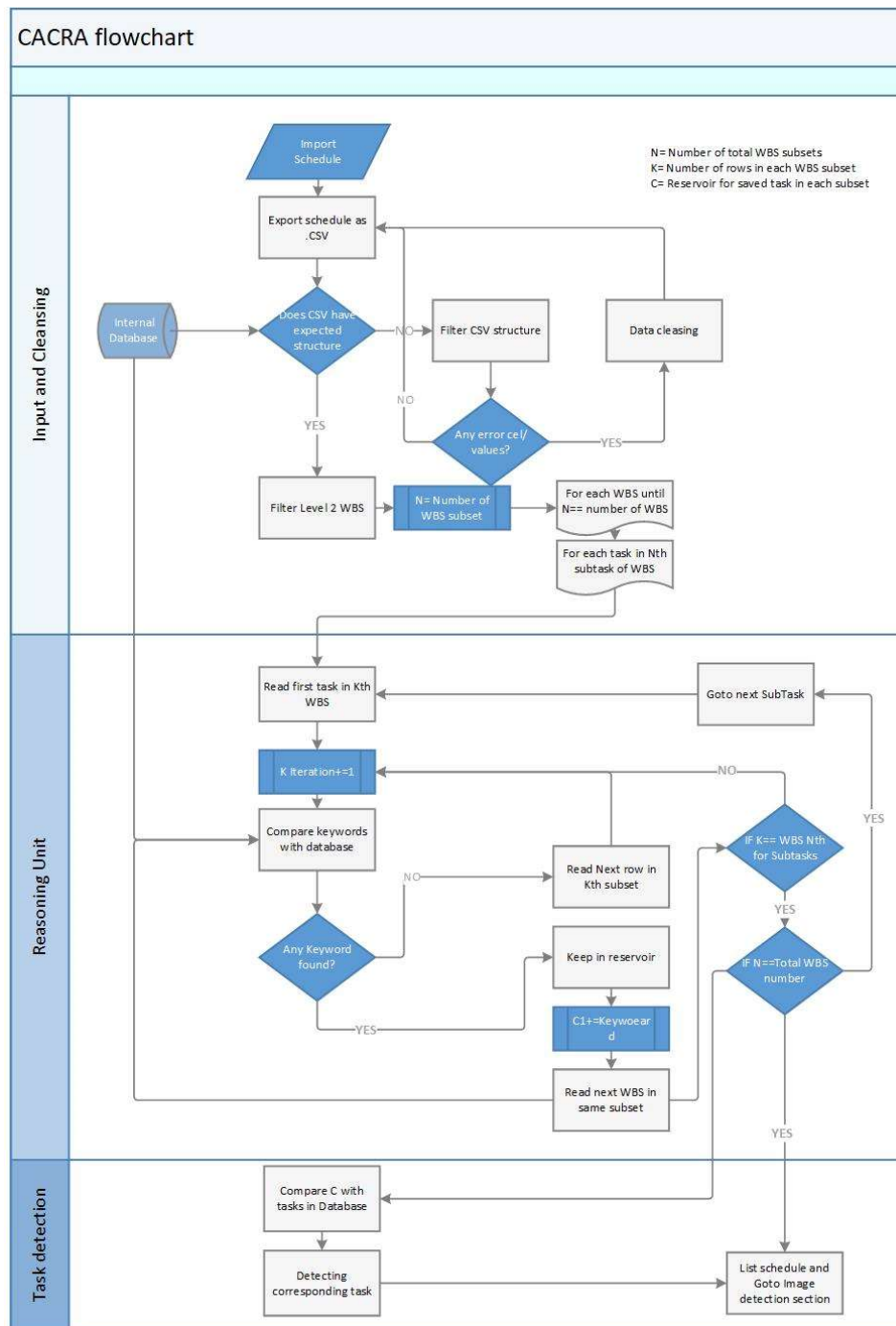


Figure 5. A flowchart of CACRA's function

To automatically update the schedule in 4D BIM projects, the schedule needs to be called, evaluated and sorted. This schedule is driven from two different sources consisting of BIM software (Revit or Vico Office) and project management software (Ms. Project). Since the CSV files are one of the standard exports for the machine learning algorithms, the schedule is exported as a CSV file to a python reasoning and cleansing algorithm. This algorithm has two explicit functions: firstly, the CSV file needs to be cleansed and error data should be deleted. For

instance, in our case, “resource” and “cost unit” columns are considered as surplus data, secondly, a reasoning algorithm sorts the WBS into a standard hierarchical context, understandable and comparable for a machine. In this paper, this algorithm is called CACRA which stands for Cleansing And Contextual Reasoning Algorithm. The whole process and the CACRA functions are elaborated in the following diagram in *Figure 5*.

4.2 Section two: Automated progress monitoring through ConvNet

4.2.1 Convolutional Neural Networks

Convolutional Neural Network (CNN) is a powerful tool for analyzing visual imagery and contextual understanding through convolutional layers [25]. Convolutional network (ConvNet) is a network of interconnected layers that convert an image to a value. **Figure 5** shows the overall structure of all the ConvNet convolutional layers, consisting of activation functions, pooling layers and fully connected layers (FC). ConvNet, on the one hand, diminishes the dimensions of the image through several convolutional or hidden layers and on the other hand, increases the number of features or depth at the output. In such a network, the preliminary patterns are processed in the first layers and complex patterns are learned in the fully connected layers [26]. Pooling layers reduce the size of each layer and make a lower resolution of the image by keeping the main dominant features of the previous layer and losing the simple features. Rectified Linear Unit (ReLU) is an activation function that adds nonlinearity into the model and returning zero or positive values in order to decrease the fading gradient effect

[11].

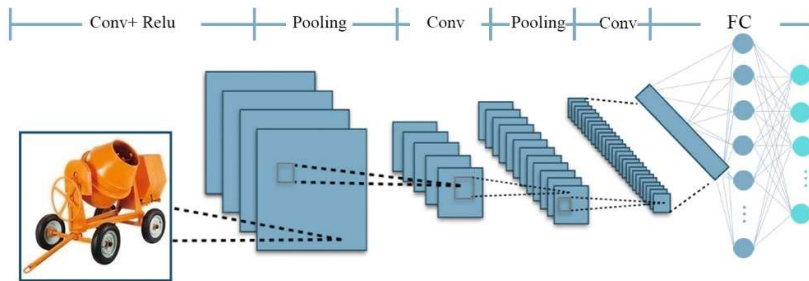


Figure 5. General components of a convolutional neural network

$$f(x) = x^+ = \max(a, x)$$

$$\max(0, ax) = a \max(0, x) \text{ for } a \geq 0$$

Another type of activation function is Softmax which is used mostly in the last layers to keep the value in a range of 0 and 1. In the above equations, a is a hyperparameter, z and σ are input and output vectors respectively [27].

$$\sigma(\mathbf{z})_i = \frac{e^{z_i}}{\sum_{j=1}^K e^{z_j}} \text{ for } i = 1, \dots, K \text{ and } \mathbf{z} = (z_1, \dots, z_K) \in \mathbb{R}^K$$

4.2.2 Automated progress monitoring through ConvNet

The updating process in construction projects, especially for 4D models, is a tedious and demanding job that entails assigning a team of inspectors and planners [28]. The precision of automated progress monitoring highly depends on the accuracy of as-built data [29]. ConvNets’ highly accurate precision can be exploited for analyzing and processing as-built data in the projects. As illustrated in **Figure 6**, a ConvNet can be utilized for training a model in order to detect the construction objects from site images in real-time and subsequently predicts the current task, objects, zone and completion status. The model, in the last step, updates the schedule (by generating a CSV updating file) and helps the project managers to keep track of project indices like variation and delay.

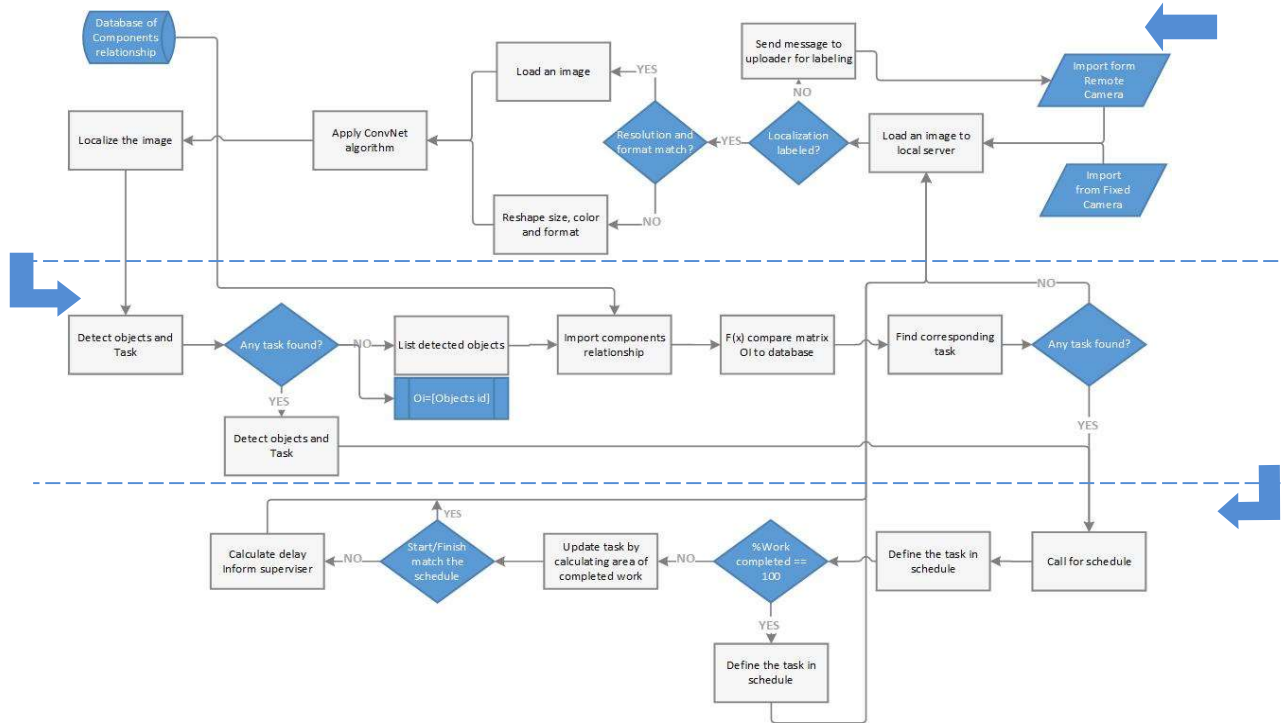


Figure 6. The task detection process at a ConvNet

Detected components by the above algorithm for each image are transferred to a task matrix. In this matrix columns equal to the number of parameters and row items show the number of items in each parameter, Sso the matrix looks as follows:

$$\begin{bmatrix} x_1^{(1)} & x_2^{(1)} & \dots & x_n^{(1)} \\ x_1^{(2)} & x_2^{(2)} & \dots & x_n^{(2)} \\ \vdots & \vdots & \ddots & \vdots \\ x_1^{(n)} & x_2^{(n)} & \dots & x_n^{(n)} \end{bmatrix} \rightarrow \begin{bmatrix} x_1^{(1)} & \dots & x_n^{(1)} \\ \vdots & \ddots & \vdots \\ x_1^{(n)} & \dots & x_n^{(n)} \end{bmatrix}$$

Index $x_j^{(i)}$ implies i th row and j th columns in the database for component parameters and if j_m, j_v, j_t, j_s, j_x respectively are components' parameters for materials, machines, tools, safety, defect, etc. the weight of each task in a subset can be calculated as follows:

$$\sum_n p_i \begin{bmatrix} J_{m1}^{(1)} & J_{v1}^{(1)} & J_{t1}^{(1)} & J_{s1}^{(1)} & J_{x1}^{(1)} & \dots & J_{i1}^{(1)} \\ J_{m2}^{(2)} & J_{v2}^{(2)} & J_{t2}^{(2)} & J_{s2}^{(2)} & J_{x2}^{(2)} & \dots & J_{i2}^{(2)} \\ \vdots & \vdots & \vdots & \vdots & \vdots & \dots & \vdots \\ J_{mn}^{(n)} & J_{vn}^{(n)} & J_{tn}^{(n)} & J_{sn}^{(n)} & J_{xn}^{(n)} & \dots & J_{in}^{(n)} \end{bmatrix}$$

5. CASE STUDY

A five-story building project has been considered for this paper where images from a ConsNet dataset are trained with a ConvNet on the base of the Inspection v4, which is a modern network architecture. To streamline the process, we considered the third stage of the construction phase (Foundation) in our normal schedule template for

a residential building. A preliminary version of ConsNet that encompass a building project has been applied.



Figure 7. Four common types of digital image processing through deep learning ConvNet

5.1 Image acquisition and labeling

As-built images were gathered from two sources consisting of fixed cameras installed on adjustable site projector posts and workers' smartphones. Besides, images shared in BIM 360 were manually labeled and localized by one of the IT personnel, and subsequently, they were sent to a trained model to test our prediction. The training dataset is fed by two different sources. The first source used a Python API for Bing Image Search [30]. This API provides wide filtering features including resolution, image type, layout, freshness, and license and allows batch downloading. The process for the application of API starts by adding thresholds for query results and saving URLs in a JSON file. Later these URLs are called for batch downloading.

The second source is an extension plugin called DAL (Download_All_Images) a customizable server extension platform for queries. The augmentation was not applied for the sake of this project since our dataset for each subset met the expected threshold. Furthermore, two online labeling platforms, MakeSense and SentiSight provided enough facilities. For simplifying the process and saving time on the labeling of 50,000 images, a single labeling method was used for most of the categories. Multiple labeling was used just for the "Task" category since in this case most of the images entailed more than one object. [31] [32].

5.2 Task-Components relationship

For this project, a diagram of the task-components' relationship was designed. **Figure 8** is a section of the diagram only for the foundation phase and demonstrates the interconnection of the three most common components including components, materials and machinery for each task. The Safety component will be supported in the second version of ConsNet. The diagram is deployed for image processing to predict a task by counting the number of objects and transferring them to a task-matrix.

5.3 ConvNet structure

The ConvNet model applied for this case study is Inception-v4, a model with three main module blocks, 43 million parameters as well as a new feature called "Reduction Blocks" [33]. Specification of the computer for this test was a PC with 8 GB RAM CPU core i7/gen4, an NVIDIA 6400 GPU and Linux Ubuntu. In total around 30,000 images were used for training the model in which the proportion consisted of 70% training, 15% validation and 15% test.

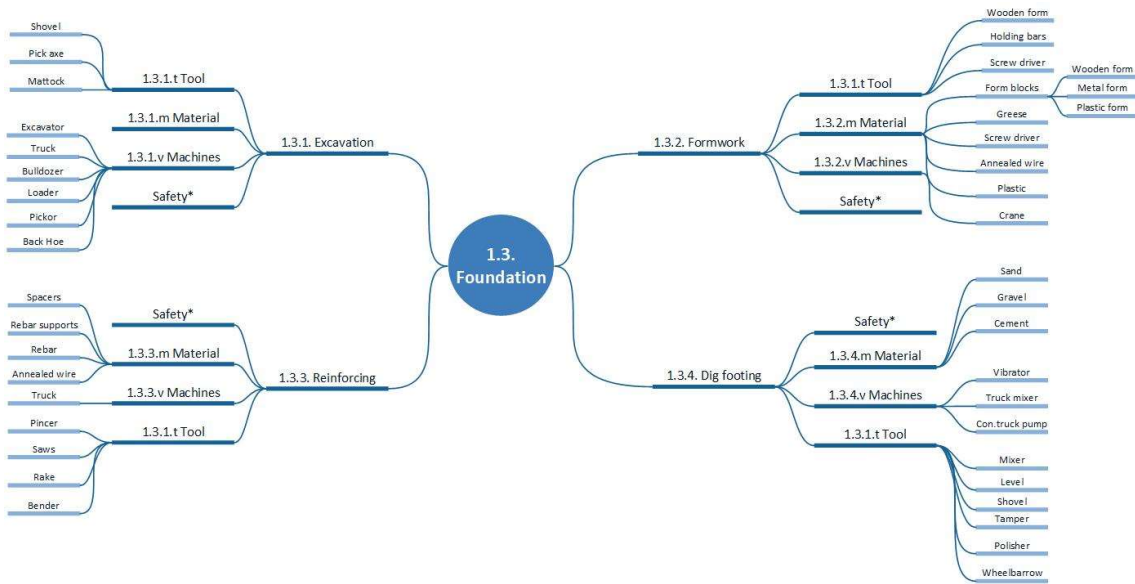


Figure 8. A sample of Task-Components relationship for building foundation operation.

5.4 Outcome

In this case study, 90% to 95% precision for foundation tasks was obtained. Having done the test twice with ConsNet and with regular Google search, the output showed a significant increase in favor of ConsNet dataset. The improvement is highlighted especially when it comes to Rebar and Formwork. Considering the similarity of these two tasks due to an extended area of rebar in the images, this improvement can be generalized for other construction works with similar patterns and edges.

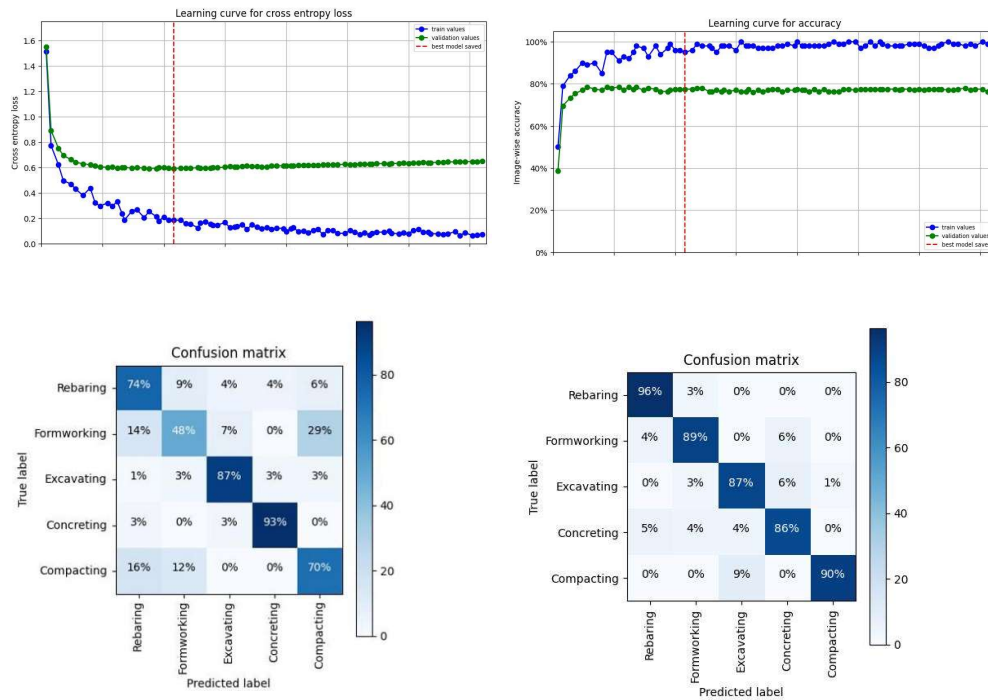


Figure 9. Left-Top: Learning curve for loss, Right-Top: Accuracy learning curve Left-Bottom: Confusion matrix when random dataset used, Right-Bottom: Confusion matrix improvement after using ConsNet dataset

For machinery, due to the shapes, colors and unique edges of machines, the result oscillated between 90% and 96% with a medium-range image dataset. Figure 9 and Figure 10 illustrate the learning curves and confusion matrix for two tests with Inception ConvNet.

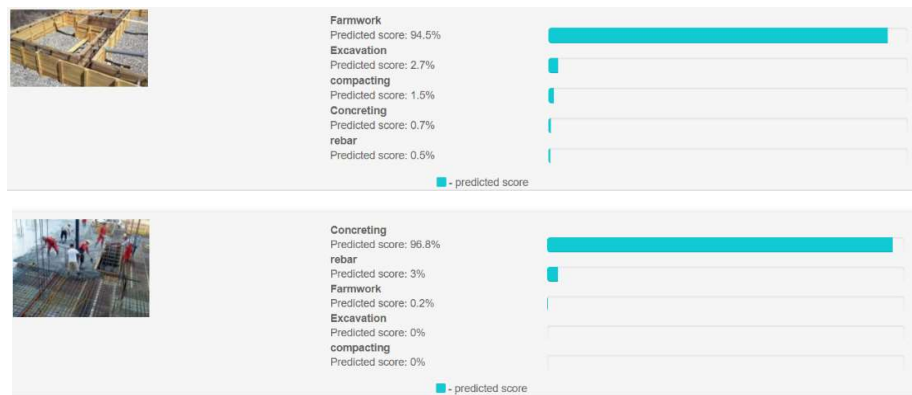


Figure 10. Two examples of test dataset with prediction score of 95% and 97%

6. CONCLUSION

In this paper, ConsNet as a reference image-dataset for construction projects is introduced. Besides, a novel method for updating the schedule through ConvNet is elaborated by CACRA, a reasoning algorithm, read schedule from 4D BIM and then translated into a standard contextual form, and subsequently, a model has then been trained to detect objects and tasks in the project. Detected objects are transferred to a task-matrix for each image. The matrix is used as the as-built model to be compared with as-planned data, and the output updates the CSV schedule file. However, elaborating the relationship between tasks and components needs to be widened and redesigned for more complicated projects.

In future works, interconnection relationships and task-matrix for more components are developed. Controlling dataset images for each subset was a manual process. We will focus on automation of this process, by training the model that detects the relevant images, skip the rest and delete duplicated ones. Further studies, also, will concentrate on the percentage of task completion by measuring the area of ongoing tasks and comparing the result with as-planned data on the 4D BIM.

7. REFERENCES

- [1] X. X. Chen, L. Liu and Y. Li, "An improved method for project duration forecasting," in *Conf. on 3-Business and E-Government*, Guangzhou, 2010.
- [2] B. McCullouch, "Automating field data collection in construction," in *Construction Congress V*, Reston, 1997.
- [3] E. Jaselskis, T. Elmisalami and B. Stephan., "Radio frequency identification tagging: Applications for the construction industry," Report to the Construction Industry Institute., Austin, 2000.
- [4] H. Son, C. Kim and Y. K. Cho, "Automated Schedule Updates Using As-Built Data and a 4D Building Information Model," *ASCE Journal of Management in Engineering*, vol. 33, no. 4, 2017.
- [5] L. Y. Liu, A. L. Stumpf, S. Y. Chin, R. Ganeshan and D. Hicks, ""Construction daily log management system

- using multimedia technology.”, *Computing in Civil Engineering*, p. 1084–1089, 1995.
- [6] J. Kim and S. Chi, "Multi-camera vision-based productivity monitoring of earthmoving operations," *Automation in Construction*, vol. 112, p. 103121, 2020.
- [7] C. Kim, H. Son and C. Kim, "Automated construction progress measurement using a 4D building information model and 3D data," *Automation in Construction*, vol. 3, pp. 75-82, 2013.
- [8] C. Wang and Y. K. Cho, "Smart scanning and near real-time 3D surface modeling of dynamic construction equipment from a point cloud," *Automation in Construction*, vol. 49, pp. 239-249, 2014.
- [9] A. Braun and A. Borrmann, "Combining inverse photogrammetry and BIM for automated labeling of construction site images for machine learning," *Automation in Construction*, vol. 102879, p. 106, 2019.
- [10] Q. Wanga and M.-K. Kim, "Applications of 3D point cloud data in the construction industry: A fifteenyear review from 2004 to 2018," *Advanced Engineering Informatics*, vol. 39, pp. 306-319, 2019.
- [11] B. Kim and S. Cho, "Automated Vision-Based Detection of Cracks on Concrete Surfaces Using a Deep Learning Technique," *Sensors*, vol. 18.10, p. 3452, 2018.
- [12] M.-W. a. I. B. Park, "Continuous localization of construction workers via integration of detection and tracking," *Automation in Construction*, vol. 72, pp. 129-142, 2016.
- [13] B. F. S. Jr., V. Hoskere and Y. Narazaki, "Advances in Computer Vision-Based Civil Infrastructure Inspection and Monitoring," *Engineering*, vol. 5, pp. 199-222, 2019.
- [14] A. Braun, S. Tutas, A. Borrmann and U. Stilla, "Automated progress monitoring based on photogrammetric point clouds and precedence relationship graphs," in *In ISARC. Proceedings of the International Symposium on Automation and Robotics in Construction*, 2015.
- [15] A. Dimitrov and M. Golparvar-Fard, "Vision-based material recognition for automated monitoring of construction progress and generating building information modeling from unordered site image collections," *Advanced Engineering Informatics*, vol. 28, no. 1, pp. 37-49, 2014.
- [16] K. Christopher, C. Koch and M. König, "Interior construction state recognition with 4D BIM registered image sequences," *Automation in construction*, vol. 86, pp. 11-32, 2018.
- [17] H. Hamledari, B. McCabe, S. Davari and A. Shahi, "Automated Schedule and Progress Updating of IFC-Based 4D BIMs," *American Society of Civil Engineers*, vol. 31, no. 4, 2017.
- [18] H. Kim, H. Kim, Y. W. Hong and H. Byun, "Detecting Construction Equipment Using a Region-Based Fully Convolutional Network and Transfer Learning," *Journal of computing in Civil Engineering*, vol. 32, no. 2, 2018.
- [19] L. Lei, Y. Zhou, H. L. and P. E. Love, "A CNN-based 3D patch registration approach for integrating sequential models in support of progress monitoring," *Advanced Engineering Informatics*, vol. 41, no. 100923, 2019.
- [20] S. Bunrit, N. Kerdprasop and K. Kerdprasop, "Evaluating on the Transfer Learning of CNN Architectures to a Construction Material Image Classification Task," *International Journal of Machine Learning and Computing*, vol. 9, no. 2, 2019.
- [21] S. Alizadehsalehi and I. Yitmen1, "A Concept for Automated Construction Progress Monitoring: Technologies Adoption for Benchmarking Project Performance Control," *Arabian Journal for Science and Engineering*, vol. 44, p. 4993–5008, 2018.
- [22] T.T. Um, F. Pfister, D. Pichler, M. L. S. Endo, S. Hirche, U. Fietzek and D. Kulić, "Data augmentation of wearable sensor data for Parkinson's disease monitoring using," in *Proceedings of the 19th ACM International*, New York, 2017.

- [23] Amazon, "Amazon Mechanical Turk," Amazon inc., 2020. [Online]. Available: <https://www.mturk.com/>.
- [24] J. Deng, W. Dong, R. Soche, L.-J. L. K. Li and L. Fei-Fei, "ImageNet: A Large-Scale Hierarchical Image Database," in *IEEE Computer Society Conference on Computer Vision and Pattern Recognition*, 2009.
- [25] M. Valueva, N. Nagornov, P. Lyakhov, G. Valuev and N. Chervyakov, "Application of the residue number system to reduce hardware costs of the convolutional neural network implementation," *Mathematics and Computers in Simulation*, vol. 177, pp. 232-243, 2020.
- [26] Y. LeCun and Y. Bengio, Convolutional networks for images, speech, and time-series,, Brain Theory Neural Networks,, 1995.
- [27] C. M. Bishop, Pattern recognition and machine learning, Springer, 2006.
- [28] R. Lopez, Chong, H.-Y., X. Wang and J. Graham, "Technical review: Analysis and appraisal of four-dimensional building information modeling usability in construction and engineering projects," *Journal of construction engineering*, no. 06015005, 2015.
- [29] V. Patraucean, I. Armeni, M. Nahangi, J. Yeung, I. Brilakis and C. Haas, "State of research in automatic as-built modelling.," *Advanced Engineering Informatics*, vol. 29, no. 2, pp. 161-171, 2015.
- [30] M. Azure, "Bing Image Search APIÆSearch for images and get comprehensive results," 2020. [Online]. Available: (<https://azure.microsoft.com/en-us/services/cognitive-services/bing-image-search-api/>).
- [31] MakeSense, "MakeSense Labeling AI," 2002. [Online]. Available: <https://www.makesense.ai/>.
- [32] SentiSight, "CNN basic workflow tutorial," 2020. [Online]. Available: <https://www.sentisight.ai/basic-workflow-tutorial/>.
- [33] C. Szegedy, S. Ioffe, V. Vanhoucke and A. A. Alemi, "Inception-v4, Inception-ResNet and the Impact of Residual Connections on Learning," in *Thirty-first AAAI conference on artificial intelligence*, 2017.

AUTOMATIC GENERATION OF 3D BUILDING MODELS FOR BIM BY POLYGON PARTITIONING AND RECTIFICATION

Kenichi Sugihara

Gifu Kyoritsu University, Japan

Zhenjiang Shen

Kanazawa University, Japan

Takahiro Murase

ChukyoGakuin University, Japan

ABSTRACT: 3D building models are of great use for many applications. The GIS and CG integrated system for automatic generation of 3D building models was proposed, based on building footprints (building polygons) on a digital map. The proposed integrated system partitions an approximately orthogonal building polygon into a set of quadrilaterals ('quads' for short) and rectifies them, placing rectangular roofs and box-shaped building bodies on these rectified quads (rectangles). Our contribution is the new methodology for partitioning and rectifying a building polygon for automatic generation. For polygon shape rectification, the vertices labelling of dividing quads is used for each quad to know which quad is adjacent to and which edge of the quad is adjacent to, which will avoid unwanted intersection of windows and doors when building bodies are combined. In this paper, the new and extended methodology is proposed for polygon shape rectification and orthogonalizing by the quad vertices labelling. In the proposed system, each quad's inclination will be parallel to or perpendicular to the inclination of 'main angle' (the average inclination of all polygon edges). However, the measured inclination of some quads can be almost opposite angle to 'main angle'. For example, if the main angle of the building polygon is -89.5 degree and the measured inclination of a certain quad is 89.5 degree, then this quad should be flipped. Since a quad will rectify itself and reconstruct according to 'adjacency', this 'flip' causes wrong reconstruction. Thus the quad vertices labelling is necessary for proper reconstruction.

KEYWORDS: automatic generation, 3D building model, polygon partitioning, quadrilateral vertices labelling, orthogonal building polygon

1. INTRODUCTION

For urban planning and architectural design, e.g., BIM (Building Information Model), it is important to create 3D building models efficiently. 3D building model creation is of great use for many applications. However, creating these 3D models needs lots of labor; manual modeling of a house with roofs by Constructive Solid Geometry (CSG) using 3D modeling software such as 3ds Max or SketchUp.

In order to automate the laborious steps, a GIS (Geographic Information System) and CG integrated system was proposed for automatic generation of 3D building models, based on building footprints (building polygons) on a digital map shown in Fig.1 left (Sugihara 2012, 2019). An orthogonal polygon can be partitioned into a set of rectangles. The proposed integrated system partitions an orthogonal building polygon into a set of rectangles and places rectangular roofs and box-shaped building bodies on these rectangles. In order to partition an orthogonal polygon, a useful polygon expression (RL expression: consecutive edges' Right or Left turns expression) and a partitioning scheme were proposed for deciding from which vertex a dividing line (DL) is drawn (Sugihara 2012).

Not all building polygons are accurately orthogonal, since technicians are drawing building polygons manually with digitizers, depending on aerial photos or satellite imagery as shown in Fig.1 left. When placing a set of boxes as building bodies for forming the buildings, there may be gaps or overlaps between these boxes if building polygons are not strictly orthogonal. To come up with the solution, the methodology has been proposed for rectifying the shape of building polygons and constructing 3D building models without any gap and overlap.

In our proposal, after approximately orthogonal building polygons are partitioned into a set of quadrilaterals ('quads' for short) and rectified into a set of mutually orthogonal rectangles, each rectangle knows which rectangle is adjacent to and which edge of the rectangle is adjacent to, which will avoid unwanted intersection of windows

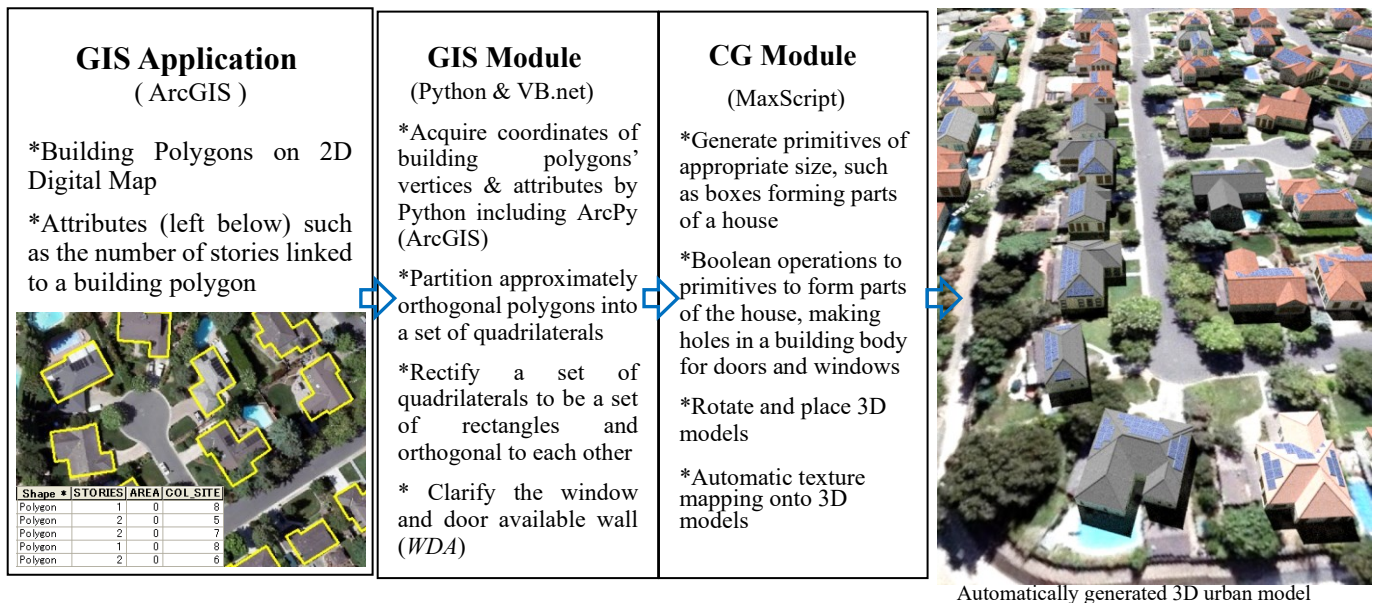


Fig.1: Pipeline of Automatic Generation for 3D Building Models

doors when building bodies are combined.

In this paper, the new and extended methodology is proposed for polygon shape rectification and orthogonalizing by the quad (quadrilateral) vertices labelling. In the proposed system, each quad's inclination will be parallel to or perpendicular to the inclination of 'main angle', i.e. the angle of a longest sum-up length of all polygon edges. However, the measured inclination of some quads can be almost opposite angle to 'main angle'.

For example, approximately vertical line segments may have the inclination of 89.5 degree or -89.5 degree, and segment vertices are labelled as such. So, if the main angle of the building polygon is -89.5 degree and the measured inclination of a certain quad is 89.5 degree, then this quad's orientation should be flipped. Since an active quad will rectify itself and reconstruct according to 'adjacency' of the active quad, this 'flip' causes wrong reconstruction. And the quad vertices labelling reveals the inclination and adjacency of all quads. To avoid wrong formations, the detection of the 'flip' and right formation are necessary.

2. RELATED WORK

When creating 3D building models, there are two types of creation approach; one is to create 3D models for existing architectures and the other for non-existing architectures. The formers are computer vision, photogrammetry, and remote sensing, which will use 3D scanner, and take stereo pictures of target architectures. The latter are architectural design and procedural modelling. Nowadays, architectural design world is experiencing a rapid shift from 2D CAD drawings to BIM 3D modellings. Previously designers create 3D models by drawing 2D CAD documents of grand plan (top view), elevation (front view) and cross section (side view), and then 3D models are created for constructing architectures which are not existing now. In architecture, designers can be said to create 3D CG building models for non-existing architectures.

Procedural modelling also aims at creating 3D models for non-existing architectures by sets of rules such as L-systems, fractals, and generative modelling language (Parish and Müller 2001). Müller et al. (2006) have created the suburbia model of Beverly Hills by using a shape grammar. They import data from a GIS database and try to classify imported mass models as basic shapes in their shape vocabulary. If this is not possible, they use a general extruded footprint together with a general roof obtained by the 'straight skeleton' computation defined by a continuous shrinking process (Aichholzer et al. 1995). Schwarz and Müller (2015) refined a procedural modeling method (grammar language CGA++) by directly accessing shapes and shape trees, operations on multiple shapes, rewriting shape (sub)trees, and spawning new trees (e.g., to explore multiple alternatives).

By using the 'straight skeleton', Kelly and Wonka (2011) present a user interface for the exterior of architectural models to interactively specify procedural extrusions, a sweep plane algorithm to compute a two-manifold architectural surface.

Even for any shape of building polygons including non-orthogonal, the straight skeleton computation makes it possible to build a roof for buildings. The limitation of a straight skeleton method is that the roofs created are only hipped roofs, since the polygon as a whole is treated for shrinking process in which each edge of the polygon moves inward at a fixed rate, resulting in a skeleton equidistant to its boundaries, i.e., a hipped roof.

By our generation method, an orthogonal building polygon is partitioned into a set of quads, and build an individual roof on each quad independently.

More recently, image-based capturing and rendering techniques, together with procedural modelling approaches, have been developed that allow buildings to be quickly generated and rendered realistically at interactive rates. Bekins et al. (2005) exploit building features taken from real-world capture scenes. Their interactive system subdivides and groups the features into feature regions that can be rearranged to texture a new model in the style of the original. The redundancy found in architecture is used to derive procedural rules describing the organization of the original building, which can then be used to automate the subdivision and texturing of a new building. This redundancy can also be used to automatically fill occluded and poorly sampled areas of the image set.

Vanega et al. (2010) interactively reconstruct 3D building models with the grammar for representing changes in building geometry that approximately follow the Manhattan-world (MW) assumption which states there is a predominance of three mutually orthogonal directions in the scene. They say automatic approaches using laser-scans or LIDAR data, combined with aerial imagery or ground-level images, suffering from one or all of low-resolution sampling, robustness, and missing surfaces. One way to improve quality or automation is to incorporate assumptions about the buildings such as MW assumption.

By the interactive modelling, 3D building models with plausible detailed façade can be achieved. However, the limitation of these modelling is the large amount of user interaction involved (Nianjuan et al. 2009), and the models created are surface models by sweeping or extruding, revolving 2D primitive geometries. When creating 3D building models for architectural design and BIM, 3D building models should be made up of solid geometries primitives which will be parts of the building, created through Boolean operation. Thus, the GIS and CG integrated system that automatically generates 3D building models immediately by CSG is proposed.

3. PIPELINE OF AUTOMATIC GENERATION

Fig.1 shows the proposed automatic building generation system consisting of GIS application (ArcGIS, ESRI Inc.), GIS module and CG module. The source of the 3D urban model is a digital residential map that contains building polygons linked with attributes data shown in Fig.1 left below, consisting of the number of storeys, the image code of roof, wall and the type of roof (gable roof, hipped roof, gambrel roof, mansard roof, temple roof and so forth). The maps are then preprocessed at the GIS module, and the CG module finally generates the 3D urban model. As a GIS module, a Python program including ArcPy (ArcGIS) acquires coordinates of building polygons' vertices and attributes. Preprocessing at the GIS module includes the procedures as follows:

(1) Calculate the length, inclination and internal angle of each edge of a building polygon. **(2)** Filter out an unnecessary vertex whose internal angle is almost 180 degrees. **(3)** Calculate a 'main angle'; the angle of a longest sum up edge length after the length of all edges are sum up according to the snapped angle of all edge inclination. **(4)** By straight skeleton computation, generate outside contours for building foundation and surrounding objects such as a fence, and also generate inside contours for placing doors, windows, and shop façades which are setback from the original building polygon. **(5)** Followed each edge of a building polygon clockwise, calculating 'cross product' of successive edges to find out an edge turns to the right ('R' vertex) or to the left ('L' vertex) by 90 degrees. **(6)** The system counts the number of consecutive 'R' vertices (= ' n_R ') between 'L' vertices. **(7)** Classify the branches by ' n_R ' and by the edge length especially incident to 'L' vertex, and by the branch dividing pattern.

(8) Prioritize the branch pattern by ' n_R ' classification, and execute dividing by the most prioritized branch. **(9)** Partition or separate approximately orthogonal polygons into a set of quads. **(10)** Rectify a set of quads to be a set of rectangles and orthogonal to each other. **(11)** Clarify 'window and door available wall' (*WDA*) on each edge of a rectangle. **(12)** Export above pre-processed data such as the coordinates of *WDA* (line segment) end vertices, each edge length of a partitioned rectangle, and attributes of buildings and so on.

The CG module receives the pre-processed data that the GIS module exports, generating 3D building models.

In GIS module, the system measures the length and inclination of the edges of the partitioned rectangle. The CG module generates a thin box (as a wall) of the length and width, measured in GIS module. In case of modelling a building with roofs, the CG module follows these steps: (1) Generate primitives of appropriate size, such as boxes, prisms or polyhedra that will form the various parts of the house. (2) Boolean operations applied to these primitives to form the shapes of parts of the house, for examples, making holes in a building body for doors and windows, making trapezoidal roof boards for a hipped roof and a temple roof. (3) Rotate parts of the house according to the inclination of the partitioned rectangle. (4) Place parts of the house. (5) Texture mapping onto these parts according to the attribute received. (6) Copy the 2nd floor to form the 3rd floor or more in case of building higher than 3 stories.

CG module has been developed using Maxscript that controls 3D CG software (3ds MAX, Autodesk Inc).

Fig.2 shows the specific example of ‘pipeline of automatic generation’ where an approximately orthogonal building polygon is given and processed, finally generating a 3D building model. When we follow the vertices and edges of an orthogonal polygon in clockwise order, an edge turns to the right or to the left by 90 degrees. Thus, an orthogonal polygon can be expressed as a set of its edges’ turning direction: an edge turning to the ‘Right’ or to the ‘Left’ (RL expression).

The orthogonal polygon with 18 vertices shown in Fig.2 is expressed as a set of its edges’ turning direction; RLLRRLRLRLRLRLRRRRL where R and L mean a change of an edge’s direction to the right and to the left, respectively. The more vertices a polygon has, the more partitioning scheme a polygon has, since the interior angle of a ‘L’ vertex is 270 degrees and two dividing lines (DLs) can be drawn from a L vertex. In our proposal, among many possible DLs, the DL (dividing line) that satisfies the following conditions is selected for partitioning.

- (1) A DL that cuts off ‘one rectangle’.
- (2) A DL whose length is shorter than the width of a ‘main roof’ that a ‘branch roof’ is supposed to extend to, where a ‘branch roof’ is a roof that is cut off by a DL and extends to a main roof.
- (3) A DL whose vertices are not shared by another DL.

These conditions (1) and (3) guarantee a complicated orthogonal polygon being partitioned into a set of rectangles by cutting a thin branch part of the polygon one by one. The condition (2) avoids the height of a branch roof is higher than the main roof’s height. How the system is finding ‘branches’ is as follows. The system counts the number of consecutive ‘R’ vertices ($=n_R$) between ‘L’ vertices. If n_R is two or more, then it can be a branch. One or two DLs can be drawn from ‘L’ vertex in a clockwise or counter-clockwise direction, depending on the length of the adjacent edges of ‘L’ vertex.

How the DL is drawn (‘Forward DL’ or ‘Backward DL’ or both ‘F&B DL’ in terms of polygon vertices that are labelled in clockwise order), that is, ‘Dividing Pattern’ is used for reconstructing a rectified polygon and saved at ‘Active Quad’ such as active quad1&2&3 shown in Fig.2 below that will extend its branch roof.

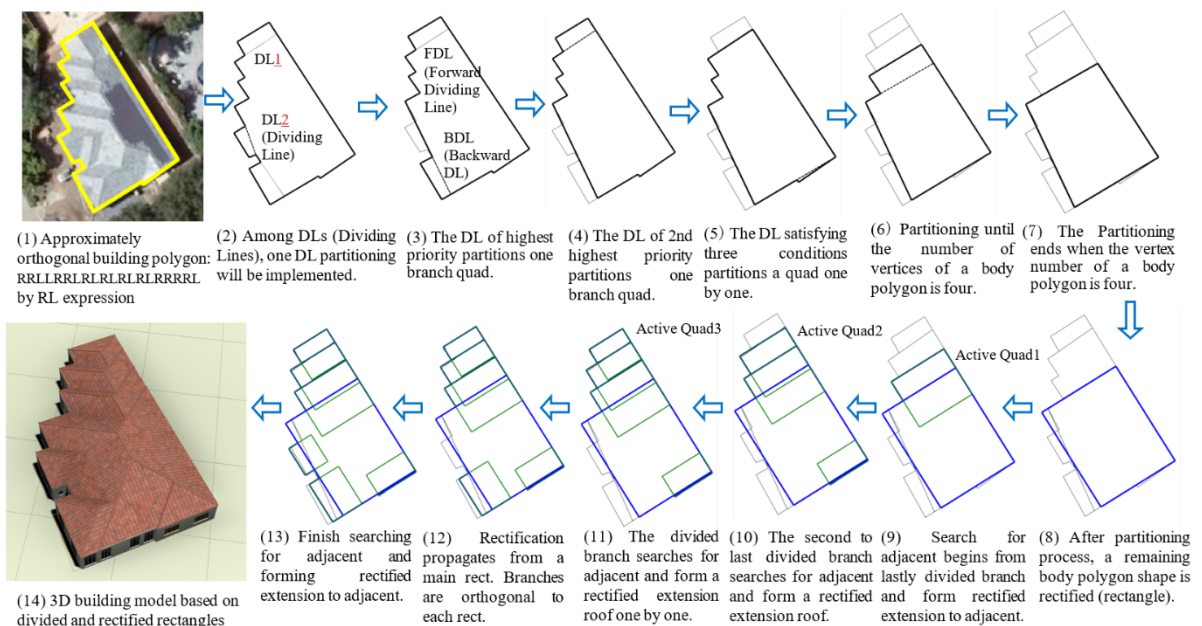


Fig.2: Detailed process of polygon partition and shape rectification, generation of 3D model

The process (polygon partitioning and rectification) at the GIS module, shown in Fig.2, is as follows. (1) The DL (Dividing Line) satisfying three conditions and the one of highest priority partitions one branch quad among DL candidates. (2) The DL of 2nd highest priority partitions one branch quad. (3) The DL satisfying three conditions partitions a branch quad one by one. (4) Partitioning continues until the number of vertices of a body polygon is four. (5) After partitioning process, a remaining body polygon (a main rectangle) is rectified into a rect (rectangle).

(6) The lastly divided branch quad (Active Quad) start searching for an adjacent quad, and forming a rectified extended branch roof to an adjacent quad. (7) The second to last divided branch quad (also Active Quad) start searching and forming a rectified extended roof. (8) 'Active Quad' searches for adjacent and form a rectified extended roof one by one. (9) Rectification propagates from a main rectangle, being every branch rectangle orthogonal to each other. (10) Finish searching for adjacent and forming rectified extension to adjacent.

The divided branch quad will be 'Active Quad'. After a building polygon being partitioned, the branch quad as 'Active Quad' will start to search for an adjacent quad by checking whether the shared edge of the branch (this is a DL) is on the edge of a possible adjacent quad one by one. For example, Active Quad1's lower edge (we call 'active edge') is part of or shared by a main rectangle's upper edge shown in Fig.2 (9). Active Quad2 and 3 also will look for an adjacent quad.

4. HOW TO BUILD BRANCH ROOFS

One after another, a branch quad is cut off at the thin part of a building polygon, and the building polygon is turned into a collection of quads. When reconstructing a building polygon for a 3D building model, each branch quad should know which quad is adjacent to and which edge of the quad is adjacent to, and how to be connected to an adjacent quad. These adjacencies are clarified and saved at the edge and quad itself. With these adjacencies, the system reconstructs a set of rectangles mutually orthogonal to each other and reveals *WDA* (window and door available wall). The adjacency is realized by the labelling the vertices of each quad. This means a quad has an orientation.

By rectification, each quad's orientation will be parallel to or perpendicular to the orientation decided by 'main angle'. For some polygons, if the measured inclination of a quads can be almost opposite angle to 'main angle', then this quad's orientation should be flipped. Since an active quad will reconstruct according to 'adjacency', this 'flip' causes wrong reconstruction.

4.1 Labelling rule for quadrilateral vertices

As shown in Fig.3, the line segment slope is calculated as $m=(y2-y1)/(x2-x1)$, where $P1=(x1,y1)$, $P2=(x2,y2)$ and $x1 < x2$ in Cartesian coordinate. In this case, P1 is on the left side of P2 in the xy-plane, since x-axis faces right in coordinate plane. When thinking of labelling the vertices of a line segment, if the leftmost vertex of a line segment is labelled P1 as an origin of the line segment, shown in the left of Fig.3, then the slope angle of the segment is from 90 degrees to -90 degrees. However, if labelling the leftmost vertex as non-origin P2 shown in the right of Fig.3 is allowed, then the slope angle of the line segment is less than -90 degrees, outside this range. Two segments have the same slope, but having different angle is not appropriate. Therefore, labelling the leftmost vertex of a line segment as an origin P1 is reasonable.

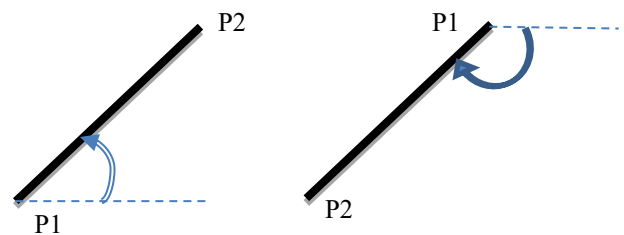


Fig.3: Line segment labelling and slope angle

What about labelling the vertices of rectangles (rects) and quadrilaterals (quads)?

The edges of a rectangle are categorized into a short edge or a long edge. As shown in Fig.4, if the vertices of a rectangle are labelled clockwise, and the starting point of an upper long edge is labelled as P1, then the slope angle of the rectangle (long edge's slope) will be limited to between 90 degrees to -90 degrees.

The starting point of an upper long edge being labelled as P1 means the starting point of right facing 'long' edge will be P1, since the vertices of a rectangle are labelled clockwise. For the same reason, the starting point of a lower long edge facing 'left' will be labelled as P3.

We are dealing with the quads similar to rectangles shown in Fig.5, in that two edges facing each other belong to a long edge or a short one. When labelling the vertices of such quads, the GIS module is measuring the length, direction and slope of all edges, and gets to know which edge is longest. The starting point of the longest edge facing right is labelled P1, or the starting point of the longest edge facing left is labelled P3 as shown in Fig.5 left and right respectively. Labelling rule in this way is consistent with the labelling for line segments.

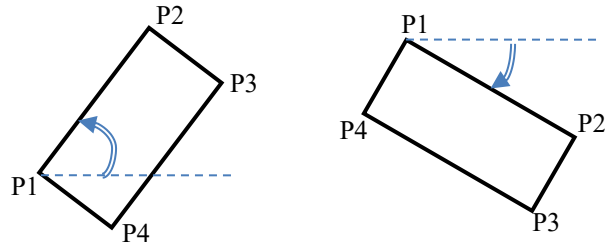


Fig.4: Rectangle vertices labelling and slope angle

4.2 Active edge

Fig.6 shows that an approximately orthogonal polygon can be partitioned into a set of quads and the branch roofs extend to a main roof. Fig.6 (b) shows quad vertices are labelled in such a way as mentioned above. The polygon of 36 vertices is expressed by RL expression; RLLRRLRLLRLLRLLRRLRLLRRLRLLRRLRLLRRL.

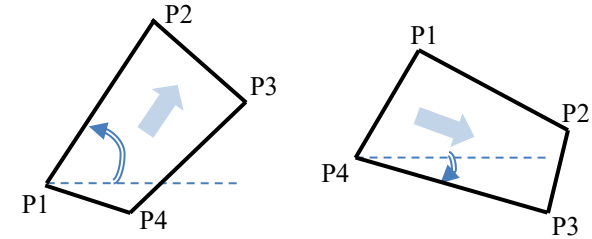


Fig.5: Quadrilateral vertices labelling and slope angle

There are nine branches of “LRRL” type. This type of branch quad (*Active Quad*) will search for and extend to an adjacent quad, and rectify itself by the *adjacency data* acquired by searching for adjacent and finding out the way a branch quad is cut off. The system uses this *adjacency data* for rectification, which will propagate from a lastly divided main rectangle in Fig.2 (7)(8). Fig.2 shows every branch quad will be rectified into a rectangle and be orthogonal to each other one after another.

The *adjacency data* is as follow; (1) Adjacent Quad ID (2) Adjacent Edge ID of Adjacent Quad (ed12,ed23,ed34,ed41 shown in Fig.6(b)) (3) Dividing Pattern : How the DL is drawn (Forward DL or Backward DL or both F&B DL shown in Fig.2(3)).

Here, Edge ID ‘ed12’ denotes an edge between P1 and P2 shown in Fig.6(b). And, *Active Quad* will look for an adjacent quad by checking which quad contains an *active edge* (a DL) of the *Active Quad*. Then ‘Active Quad’ will check which edge of the quad found contains an active edge. Thus, the adjacency data (1) (2) are acquired by checking whether the DL (Active Edge) is on the edge of possible adjacent quads one by one. And, we get the adjacency data (3) when cutting off the branch quad.

When a quad is cut off, four vertices of the quad are given, and the system will assign the ‘local edge number’ to each edge of the divided quad based on the order of the four vertices. A ‘local edge number’ is assigned to a divided quad, whose edges are labelled from one (1) to four (4) in clockwise order shown in Fig.6(b), while all edges of the whole polygon are assigned a ‘global edge number’.

Here, an *Active Edge* is given by Table 1 where “Longest local edge number” and its direction, i.e., “Longest edge direction” decide *Active Edge*, since *Active Edge* is sure to be the fourth edge (4) by ‘local edge numbering’.

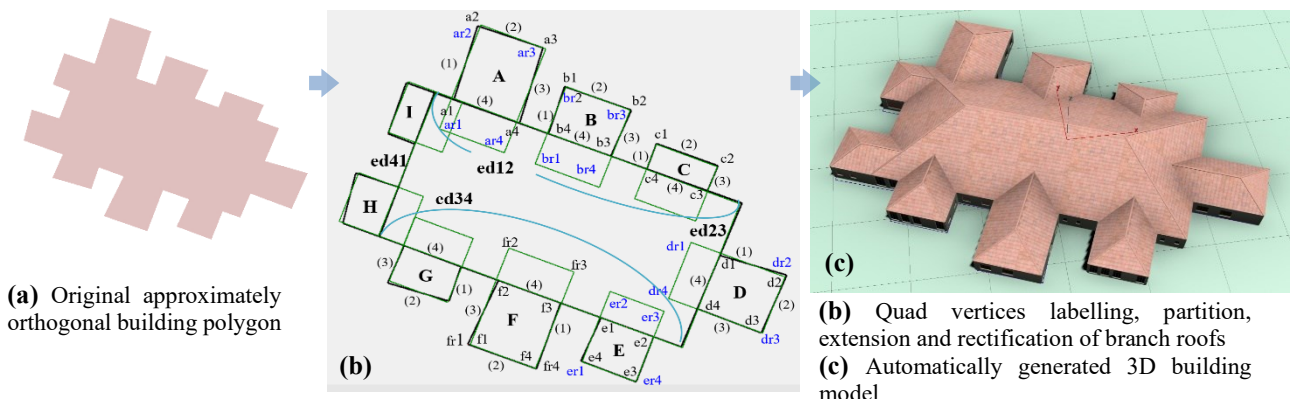


Fig.6: Partition, extension and rectification of branch roofs by quad vertices labelling

When reconstructing geometric primitives such as a circle, a regular polygon or a L-shaped polygon, we have to estimate and calculate parameters of these primitives, i.e., edge length, interior angle, polygon slope, a polygon centroid position, and a reference point ('starting point' one choose to describe the location) and so on. For example, if we reconstruct a circle from an approximately round shaped object, then we try to estimate and calculate a centroid and radius for a circle.

In our research, we reconstruct rectangles by estimating and calculating parameters for a rectangle, such as long and short edge length, inclination and 'reference point' from a divided quad. The labelling rule, as mentioned in section 4.1, assigns a label to each vertex of a quad, i.e., declaring that the starting point of the longest edge facing right is labelled P1, or the starting point of the longest edge facing left is labelled P3. By this rule, Table 1 shows which edge will be an active edge, and we know rectangle parameters and then can reconstruct rectangles.

Table 1: Active Edge, Longest edge number & direction

Longest local edge number	Longest edge direction	Active Edge (Adjacent Edge)	Gable side edge	Branch quad in Fig.6
1	Right	ad41	ed23	A, D
1	Left	ad23	ed41	F
2	Right	ad34	ed12	B, C, H, I
2	Left	ad12	ed34	E, G
3	Right	ad23	ed41	F
3	Left	ad41	ed23	A, D
4	Right	ad12	ed34	E, G
4	Left	ad34	ed12	B,C,H,I

After finding out an adjacent quad and an adjacent edge, an active quad rectifies itself based on the adjacency and extends to a main rectangle by half of active edge length as shown in Fig.6(b). Thus, given two rectangles; one for an extended branch roof ('roof rect' for short) and the other for no-extended branch house body ('body rect' for short) under the branch roof, we will build a branch roof and a house body upon these two rects.

5. WDA clarification

In our research, an approximately orthogonal polygon is partitioned into a set of quads. Quads are combined through shared edges such as an active edge or a stored edge. And, walls will be built on the edges of the quad except shared edges, resulting in the whole orthogonal polygon being surrounded by walls. When installing windows or doors to walls, we have to clarify where the wall will stand. Fig.7(b) shows the branch quads share the same edge of a main quad. If 'windows and doors available' (*WDA* for short) walls are not clarified, then windows may not be properly installed and will be intersected by the wall of a branch quad. This unwanted intersection is also pointed out by Muller et al. (2006). In their research, unwanted intersections will cut windows (or other elements) in unnatural ways, as the volumes are not aware of each other.

Thus, it is of great significance for a constituent element to know neighboring elements. In our system, an element knows a neighbor when the neighbor being cut off.

Fig.7 shows how *WDA* (window and door available) wall is clarified. When branch quads being cut off, they have left traces on a main quad. The system classifies these traces, and sorts them, then *WDA* being revealed. The clarification procedure is as follows.

(1) Acquire 'adjacency data' (adjacent quad ID, edge ID and dividing pattern) and 'trace data' (vertices' position of an active edge) when branch quads are cut off. For example, as for ed12 of a main quad, there are three branch quads and their footprints on ed12 are a4(=pt1), a3, b3, b2, c4 and c3(=pt2), as shown in Fig.7(b).

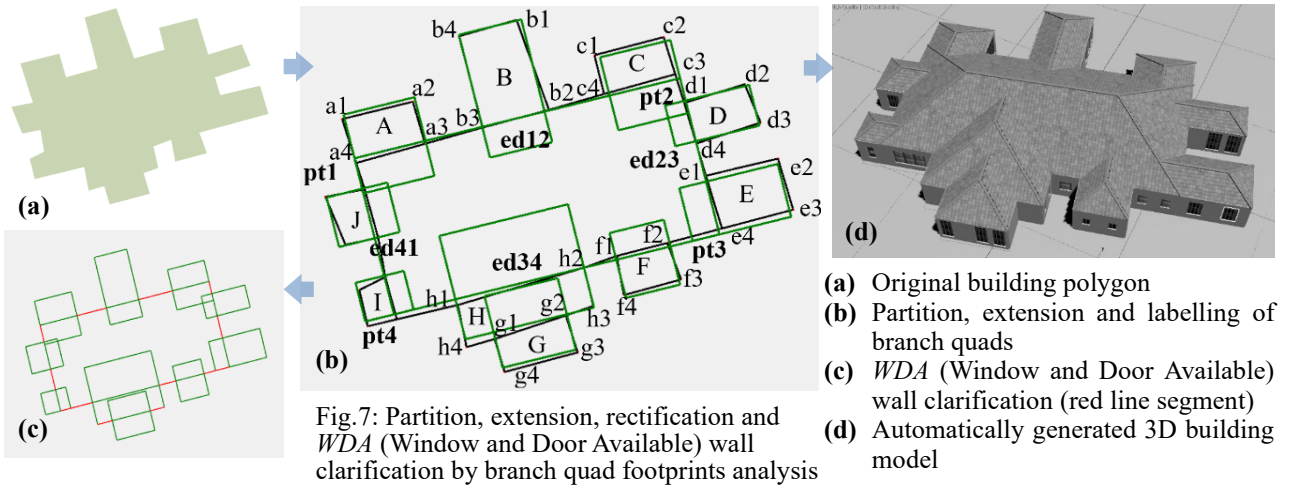
(2) The system counts the number of footprints vertices (=n_v) on each edge of the main quad, every time an active edge has found quad ID and edge ID. And, the n_v of the active edge will be zero for the active edge since no wall is on the active edge.

(3) Footprints vertices on each edge of the main quad are sorted according to the distance from each edge endpoint. So, calculate the distance between each footprint vertex and the endpoint.

(4) *WDA* is dependent upon whether a main quad has branch quads cut off by FDL (Forward Dividing Line) or BDL (Backward Dividing Line). For example, there are FDL and BDL branch quads on the ed12 of a main quad, as shown in Fig.7(b). In clockwise order, *WDA* starts by a3; the vertex of the active edge (a3-a4).

And, the *WDA* segments will be (a3, b3), (b2, c4) in Fig.7(b), also illustrated by red segments in Fig.7(c).

There are no FDL and BDL branch on the ed34, resulting in *WDA* of (pt3, f2), (f1, h2), (h1, pt4), and the number



of *WDA* segments is three, whereas there are three branches on the ed12 with the *WDA* segment number ($= n_{wda}$) being only two.

(5) Export whether a wall will be built on every edge of all rects and, if any, export *WDA* for each edge. If one wall stands on one edge, then $n_{wda} = 1$.

If no wall for an active edge, $n_{wda} = 0$. If *WDA* exists, export n_{wda} , and then length, inclination, and vertices position of *WDA* segments.

After the CG module importing these data, it will build walls and install windows depending on the windows standard interval embedded in the CG module.

Thus, the GIS module (Fig.1) will export the reconstruction data of the rectified quads for body rects and roof rects; long side length, short side length and inclination of two rects for each divided quad. And, CG module will create 3D building models by the unit of each rectified quad, one after another. For some quad, a body rect and a roof rect are the same shape with the roof independently built on the body rect, whereas most roof rects are extended at least one side to neighbors.

6. CONCLUSIONS

In our partitioning methodology, the system is looking for the thin part of an approximately orthogonal polygon, such as the root of its branches, and cut it off with the most suitable dividing line (DL). The polygon is partitioned into a set of quads (quadrilaterals). The branch quads are classified based on how the DL is drawn, the number of the remaining original branch vertices ($= n_R$: the number of consecutive 'R' vertices between 'L' vertices, where 'R' vertices will be the remaining original branch vertices), and the length of the edge that indicates the thickness of the branch, such as the ones incident to 'L' vertices. Most branches will extend their roofs. However, when a branch quad being divided and separated as one isolated quad, the divided quad does not know which edge will be extended as a branch roof. In our research, we know that the edge whose relative edge number is four is the edge stuck on the main. And, the fourth edge will look for a neighbor as an active edge. At the same time, the vertices of these quads are numbered by our labelling rule. By this labelling rule, the quad gets to know which quad is adjacent to and which edge of the adjacent quad is connected to, and the quad's orientation is also revealed.

When a set of quads is rectified into a set of rectangles all of which are orthogonal to each other, all quads have to face to the fixed orientation or face perpendicularly to this orientation decided by the main angle.

If a set of quads consists of almost vertical quads whose orientation angle are around 89 or -89 degree and the main angle is 89 degree, then the quad with the angle of -89 degree has to flip its orientation, which causes the rectification design errors. To avoid this error, the system will detect whether the flip occurs or not by checking if the difference of its own orientation angle and the main angle is greater than around 150 degree. When a flip happens, the system will use 'the quad's vertices position after the flip' as reference points for reconstruction.

Four vertices form a quad and a rect. If the polygon cut off has four vertices that used to belong to the main polygon, then it can form a quad and a rect without calculating the intersection between the polygon edges

around 'L' vertices for the quad vertex as shown in Fig.2(2)(3)(4)(6). It is true for the polygon cut off has three vertices which used to be the vertices of the main polygon. This is because the position of the three vertices of the rect are decided and then the fourth vertex's position of the rect will be decided. Therefore, if the polygon cut off contains three previously main polygon vertices and the rectangle shape is determined, then this polygon will not extend to a neighbor but absorb a branch roof from an adjacent quad. This is the case of 'stored edge'.

However, if the polygon cut off has only two vertices that previously belong to the main polygon, then it cannot form a quad and a rect. The system has to calculate the intersection between the polygon edges around 'L' vertices for the quad vertex as shown in Fig.2(2)(3)(4)(6), where the intersection between a FDL from 'L' vertex and the polygon edge (two edges successor) is calculated as the fourth quad vertex.

When we install windows or doors to walls properly, we have to clarify where the wall will stand; 'windows and doors available' (*WDA*) walls. If *WDA* is not clarified, then windows may be intersected by the wall of a branch quad, which will lead to an unwanted intersection.

When branch quads are cut off, they have left traces (footprints) on a main quad, and the system acquires and saves 'adjacency data' and 'trace data' (footprint vertices' position). Footprints vertices on each edge of the main quad are sorted according to the distance from each edge endpoint. *WDA* is given based upon whether a main quad has branch quads cut off by FDL or BDL. Thus, the system classifies these traces and sorts them, and then *WDA* will be revealed. Fig.8 shows approximately orthogonal building polygons on the digital map; the source of 3D town model, and the process of polygon partitioning, shape rectification, and *WDA* clarification and finally generation of 3D building models as residential area.

Fig.9 shows BIM 3D Model at Revit (BIM software of Autodesk) which is imported from 3ds MAX (DXF file) being classified as several downloadable families. Revit can import CAD formats: DGN, DWF, DWG, DXF, IFC. And, 3ds Max can export DWG or DXF files to Revit by following the instructions how to export them. Among CAD formats, the IFC file can have a lot of BIM information attached to it. But, now, 3ds Max cannot import IFC models in different settings, since 3ds Max does not have such data structure and precision as 3DCAD for building and structural design. However, automatically generated 3D Model imported from 3ds MAX can be rough sketches for BIM modelling and useful for designers to come up with new ideas.

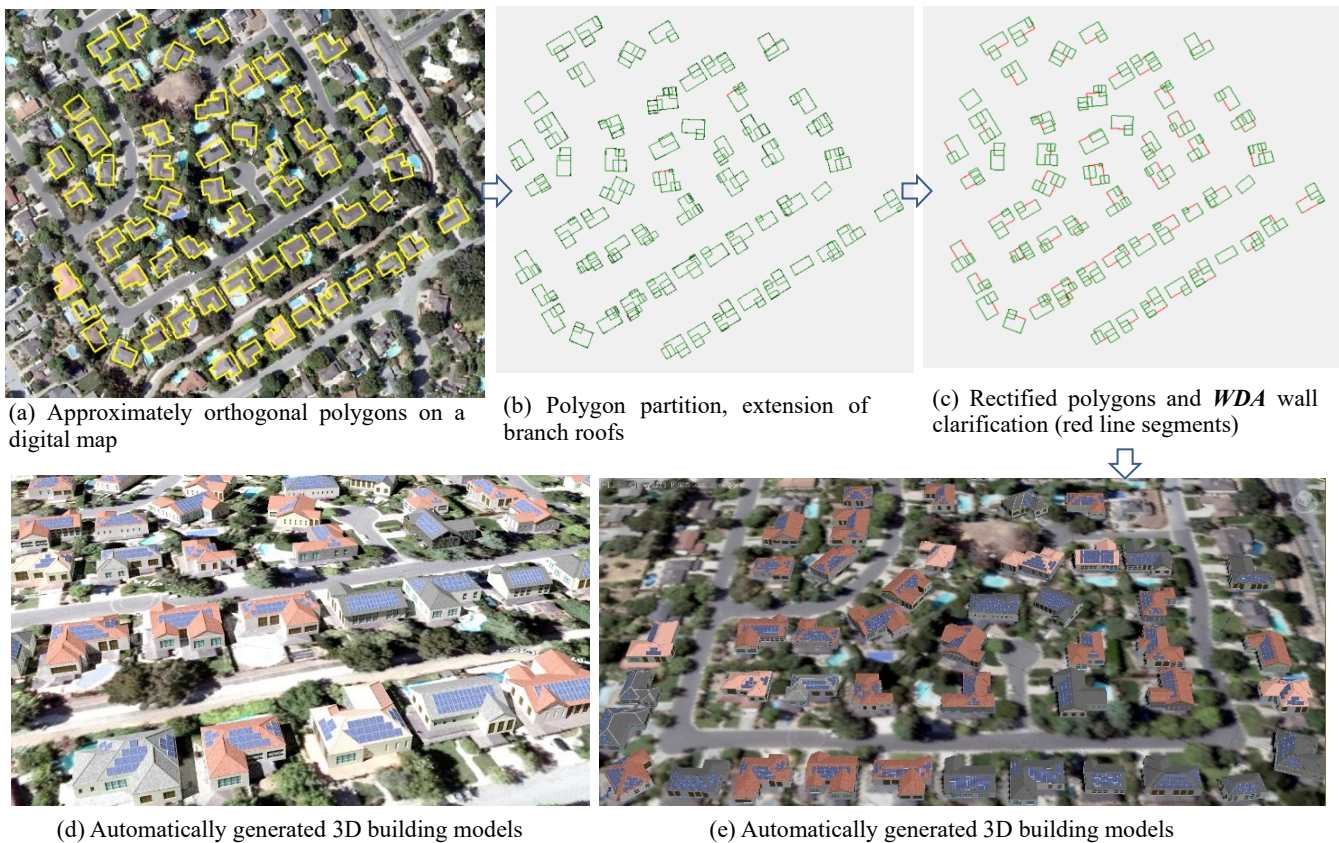


Fig.8: Process of polygon partition, shape rectification, *WDA* clarification and generation of 3D models

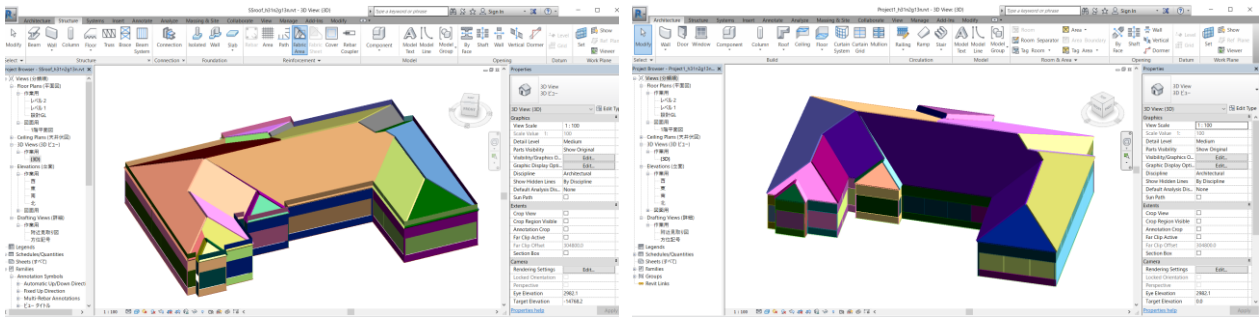


Fig.9: BIM 3D Model at Revit (BIM software of Autodesk) which is imported from 3ds MAX (DXF file) classified as several downloadable families, assigned materials, thickness and structure.

The advantage of our generation system is that our 3D building models created through Boolean operation between geometric primitives (CSG) can be utilized for architectural design, i.e., BIM, while 3D models created by procedural modeling are not solid models but surface models which are to be converted into geometric primitives when they are used for construction design.

The limitation of our work is that our proposed system can export the geometry of 3D building models without BIM structural data such as materials (its appearance, cost, manufacturer, etc.) and compositions (wall, slab, roof and generic). Exporting these BIM data attached to the geometry will be our future work, getting along with updating and advancing of 3ds Max for BIM.

ACKNOWLEDGMENTS

This work was funded by JSPS KAKENHI; Grant-in-Aid for Scientific Research (C) Grant Numbers 20K03138, 19K04750, 18K04523.

7. REFERENCES (STYLE HEADING 2)

- Aichholzer O., Aurenhammer F. and Alberts D., Gärtner B. (1995). A novel type of skeleton for polygons, *Journal of Universal Computer Science*, 1 (12): 752–761.
- Aliaga G. Daniel, Rosen A. Paul ,and Bekins R. Daniel (2007). Style Grammars for interactive Visualization of Architecture, *Visualization and Computer Graphics*, IEEE Transactions on Volume:13, 786 – 797.
- Bekins R. Daniel ,and Aliaga G. Daniel (2005). Build-by-number: rearranging the real world to visualize novel architectural spaces, *Visualization, VIS 05. IEEE*, 143 – 150.
- Jiang N., Tan P., Cheong L. F. (2009). Symmetric architecture modeling with a single image, *Proc. SIGGRAPH Asia '09*, papers No.113, Pages 1–8.
- Kelly Tom, Wonka Peter (2011). Interactive Architectural Modeling with Procedural Extrusions, *ACM Transactions on Graphics (TOG)* 30 (2), 14.
- Michael Schwarz and Pascal Müller (2015). Advanced Procedural Modeling of Architecture, *ACM Transactions on Graphics*, No.107.
- Parish I. H. Yoav, and Müller Pascal (2001). Procedural modeling of cities, *Proceedings of ACM SIGGRAPH 2001*, ACM Press, E. Fiume, Ed., New York, 301–308.

Pascal Mueller, Peter Wonka, Simon Haegler, Andreas Ulmer, Luc Van Gool. (2006). Procedural modeling of buildings, *ACM Transactions on Graphics* 25, 3, 614–623.

Nianjuan, Jiang, Ping, Tan, and Loong-Fah, Cheong (2009). Symmetric architecture modeling with a single image, *ACM Transactions on Graphics - TOG*, vol. 28, no.5.

Sugihara, K. and Kikata, J.(2013). Automatic Generation of 3D Building Models from Complicated Building Polygons, *Journal of Computing in Civil Engineering, ASCE*, Volume 27 Issue 5.

Sugihara Kenichi (2019). Straight Skeleton Computation Optimized for Roof Model Generation, *WSCG 2019, International Conference in Central Europe on Computer Graphics, Visualization and Computer Vision*, 101–109.

Vanegas A. Carlos, Aliaga G. Daniel, Beneš Bedřich (2010). Building reconstruction using Manhattan-world grammars, *Computer Vision and Pattern Recognition (CVPR)*, IEEE Conference on: 358 – 365.

AUTOMATED BIM-BASED FORMWORK QUANTITY TAKE-OFF

Yasar Cepni & Asli Akcamete

Middle East Technical University, Turkey

Ralf Klein

KU Leuven, Belgium

ABSTRACT: *Quantity take-off (QTO) is an indispensable part of construction projects since it is used for scheduling and cost calculation. However, obtaining accurate QTOs from 2D traditional drawings is tedious and time-consuming. Therefore, the use of BIM for QTO is increasing. According to literature, the accurate, automated calculation of formwork areas from BIM remains still problematic. This is mainly due to lack of modeling conventions, agreed workflows, and classification, together with modeling errors like overlapping structural elements and limitations of BIM software. It is important to note that QTO is needed during several phases of the design and construction process, with differing requirements and available information. Moreover, automated formwork generation is not supported by the majority of BIM tools although it is also a time-consuming task and necessary for construction phase planning, visualization, and interference check. Therefore, this publication describes how the extraction of formwork quantities and the creation of formwork models can be automated with Autodesk Revit Dynamo. A case study is presented, and the results obtained from the presented algorithm are verified with the manual operation of the BIM quantification features as well as manual calculations for some elements. Consequently, accurate and faster formwork quantification results and generic formwork models are automatically obtained. Ongoing research is focused on the extension of the tool to automate the creation of formwork models for 4D modeling for the construction stage, including the aspects of scheduling and clash detection in the context of open-BIM.*

KEYWORDS: *Automation, Building Information Modeling (BIM), BIM-Based Quantity Take-Off, Formwork*

1. INTRODUCTION

Material quantity take-off (QTO) plays a prominent role in the construction industry starting from the early design stage, before tendering and preconstruction stage, and during the construction phase to assist scheduling and cost calculations (Monteiro & Martins, 2013). Generally, the QTO process includes identification of items and their relations on drawings, obtaining dimensions, and calculating units of measurements such as areas, volumes, and linear meters (Shen & Issa, 2010). Hence, despite its importance, QTO requires a significant amount of time to interpret conventional printed and CAD drawings (Sabol, 2008). Besides, estimators need to investigate each drawing set carefully and perform calculations meticulously so that errors due to double counting and omissions can be eliminated (Olsen & Taylor, 2017). On the other hand, BIM has a potential to enable more accurate and faster material QTO process while minimizing fluctuations in the cost calculation stages (Sabol, 2008). It is because information for cost estimation is already included or linked in BIM, which reduces errors and misinterpretations, and it can be automatically updated when design changes (Ashcraft, 2008).

However, the reliability of BIM-based quantification is generally questioned owing to modeling mistakes, limitations in BIM tools, and not establishing ground rules for the modeling process (Bečvarovská & Matějka, 2014). Difficulties in the implementation of classification systems into BIM, lack of level of development (LOD) in different project phases where needed, and exchange of building data among distinct tools are also main challenges for BIM-based QTO (Firat et al., 2010). Furthermore, design models may provide inadequate and excessive quantities since they contain less detailed BIM objects due to the modeling process (Khosakitchalert et al., 2019a). Consequently, BIM-based QTO requires further research to increase its reliability.

In the case of concrete formwork, the geometric accuracy of BIM models and concrete placement sequence significantly affects the quantification results. Usually, it is unlikely to extract complete and systematic formwork QTOs from BIM models due to the intersection between different elements resulting in excess material quantification (Monteiro & Martins, 2013). Likewise, overlapping volumes of structural components and software limitations complicate BIM-based formwork quantification. Besides, formwork is a temporary structure in the construction phase, and creating detailed formwork models for QTO extraction requires time and rigorous work (Khosakitchalert et al., 2019b). Therefore, investing additional time and work is generally not favorable for a provisional activity from the construction practitioner's standpoint.

This research proposes a framework to calculate concrete formwork areas and automatically generate generic formwork panels with distinctive information for the classification of area quantities with respect to different

structural elements. For this purpose, a reinforced concrete (RC) building is created in the BIM environment to compare the accuracy and estimation time of quantification obtained from the proposed method and conventional BIM-based quantification approach together with manual calculations. Moreover, a limited investigation of open BIM standard IFC is also performed, and eventually, research results are discussed, and possible future works are explained.

2. PRELIMINARY RESEARCH

2.1 Limitations of BIM-Based Quantity Take-Off

Traditional QTO gets iterative and ineffective since design development between different phases and activities create time lags during reviews, and consequently, cost estimation and QTO becomes slower (Cheung et al., 2012). Nonetheless, BIM-based QTO enables estimators to access material quantities in various formats for examining and grouping information whenever it is essential (Masood et al., 2014). However, architecture, engineering, and construction (AEC) industry generally confront problems in BIM-based quantification. It is because the quality of BIM models is not trustworthy due to a lack of understanding of automated QTO among estimators and limitation of solid knowledge of the QTO process, which may result in not realizing CAD/BIM problems in terms of QTO (Smith, 2014). Moreover, the time spent on checking models and updating information with misleading data brings about entanglements in BIM-based QTO (Olsen & Taylor, 2017). The requirement for control and modification of existing BIM data is mainly caused by the lack of modeling conventions and agreed workflows during the project execution.

For this reason, models need to be developed following the construction sequence with proper modeling guidelines and a sufficient level of detail, which agreed upon by all stakeholders (Firat et al., 2010). For example, while linear meter for a particular type of wall is sufficient for early estimations, contractors need to know the type of gypsum boards, the number of wall layers, frames, and even screw quantities in cost calculation during the construction stage (Sabol, 2008). Hence, models with the required information need to be provided for efficient BIM-based estimation. Furthermore, BIM tools should be appropriate for QTO and cost calculations, and information needs to be complete and quantitative (Aram et al., 2014). In light of these limitations, quantification using BIM requires extensive modeling approaches and high adoption of BIM software. Similarly, concrete formwork QTO is affected both from modeling conventions and software limitations, and eventually, formwork quantification and visualization become a problem in the BIM platform, especially for the contractors. It is because object information of the 3D structural components cannot be directly utilized to extract the formwork area unless additional formwork modeling is done in the current state of the art (Cho & Chun, 2015). Meanwhile, manual modeling of formwork is time-consuming and error-prone, which increases the importance of the automatic generation of formwork models with required area information.

2.2 BIM-Based Formwork Quantification

BIM tools neither have a specific tool for formwork modeling nor calculate the formwork areas correctly where building components intersect with each other (Monteiro & Martins, 2013). However, the quantification of formwork depends on the information in models; otherwise, estimation of formwork bases upon statistical approaches resulting in less accuracy and inefficient process (Cho & Chun, 2015). Therefore, several types of research have been focusing on improving the accuracy of BIM-based formwork quantification. For example, Meadati et al. (2011) proposed a BIM-based repository by associating additional information to 3D models for design checks, material take-off, constructability analysis, and automatic shop drawing preparation in Autodesk Revit and Navisworks environment. Kannan & Santhi (2013) created formwork components in Autodesk Revit for a high rise building and simulated formwork activities in Navisworks by integrating with the construction schedule. Lee et al. (2017) developed an object-oriented approach to integrate schedule and cost estimation using ArchiCAD models for labor productivity in formwork activities. Khosakitchalert et al. (2019a) suggested utilizing their visual programming approach BCEQTI (BIM-based compound element quantity take-off improvement) for calculating structural concrete volumes and formwork areas. Recently, Khosakitchalert et al. (2019b) proposed a visual algorithm based on their previous studies and calculated structural formwork areas of an RC building.

Although there are a few studies using visual programming to calculate formwork quantities from BIM, it is observed that the previous algorithms have not been tested to calculate RC objects with complex geometries. For example, the faces of the rectangular and arched openings in the walls and inclined surfaces of columns, beams, and walls, which are posing challenges, are not included in the previous algorithms. Therefore, in this study, we have developed an algorithm that can accurately calculate formwork areas from a building model, including

slanted columns, tapered beams, inclined wall surfaces, arched wall openings, and circular columns with drop panels. Another goal of the research is to generate formwork panels for each formwork surface using generic models and store some relevant information such as formwork area and formwork ID in the formwork model for future activities. In addition to accuracy, time comparison is also made to reveal the speed of automated formwork quantification.

3. CASE STUDY MODEL

This research is focused on reinforced concrete (RC) structures, hence a two-story RC building with a courtyard area in the center is created in Autodesk Revit 2021 for the case study implementation. Figure 1 illustrates the building overview and detailed visualization of several structural components. Tapered beams, inclined wall surfaces, slanted columns, circular columns with drop panels, and arched opening heads for windows are explicitly added in the model since these types of conditions complicate the formwork estimation. Tapered beams are created by cutting typical rectangular beams with mass components, and slanted columns are modeled utilizing mass in place feature in the BIM tool. All other elements are created using available families in the software library. The formwork area for each structural category is calculated and visualized by using Dynamo 2.5.0.7586, a well-known visual programming tool integrated into Autodesk Revit. Moreover, this case study is performed by utilizing a computer with internal working memory (RAM) of 16 GB, Intel Core i7-9750H 2.6 GHz CPU, and NVIDIA GeForce RTX 2060 6GB video card.

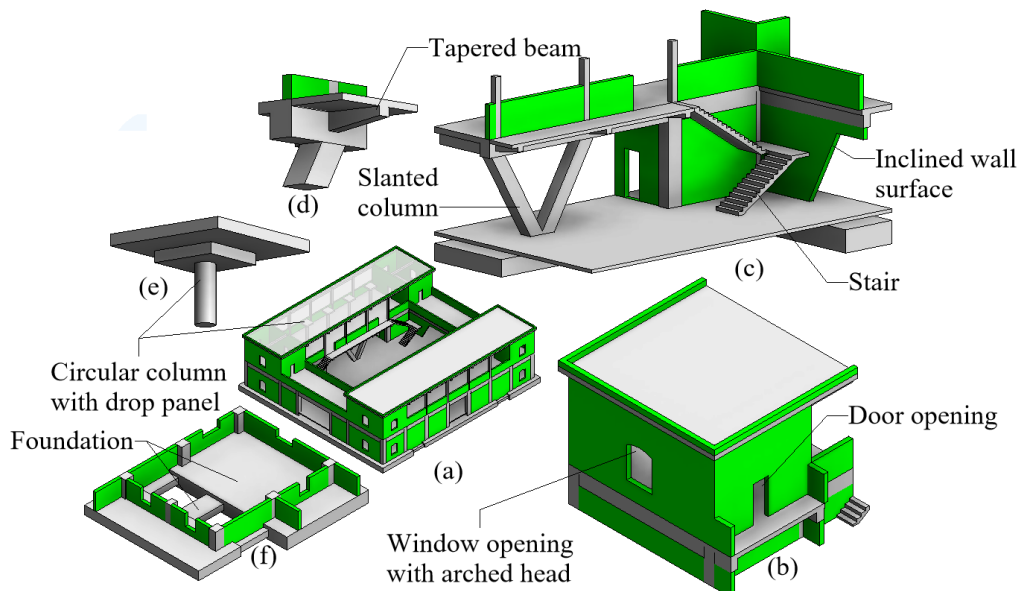


Fig. 1: Building model with the detailed view of structural components in Autodesk Revit environment

4. PROPOSED METHOD

Constructions are executed in a systematic way such that foundations are cast first, and walls and columns follow the foundations. Structural slabs and beams are placed upon completion of vertical structural elements. Stair and parapet walls are generally constructed after casting the adjacent components. This hierarchy is also considered in the development and application of the proposed method so that the formwork area of a structural category is calculated by intersecting its surfaces with other structural categories to eliminate surfaces, which do not require formwork. For example, beam and slab elements are built on structural walls and columns; hence, some surfaces of beams and slabs do not require formwork since they are already enclosed with columns and walls. Besides, stairs are not included in the calculation of other categories since surfaces, which stairs intersect with other elements, need to be formed separately in the real situation considering the construction sequence.

The proposed method aims to eliminate overlapping areas between the same and different structural components to obtain area information correctly. It also extracts the formwork areas, which is not ordinarily possible to calculate due to software limitations such as beam-column intersections and wall opening surfaces. Figure 2 illustrates the framework of the algorithm to calculate and visualize formwork elements. The method consists of both manual and automated processes, and the process for all structural categories is the same. The manual process is done by the user, and it includes the creation of a structural view, assigning project parameters, grouping, and saving formwork models and linking the formwork model back to the original model at the end.

The automated process is done by Revit Dynamo. It detects intersections and overlaps between structural elements, filters formwork requiring surfaces, creates formwork panels, and export results in a spreadsheet. The method is applied for each structural category at different times in such a way that one category is selected for formwork calculation at a time, while others are used for eliminating overlapping and intersected surfaces of the formwork category.

The process starts with the creation of a 3D structural view, including only structural components, and then three different project parameters *formwork area*, *formwork type*, and *formwork ID* are assigned for generic model categories. These parameters are automatically filled by the algorithm later, and the only purpose here is to allocate an information space within the generic model category, which is also the category of formwork models. Moreover, "parapet" information is added for parapet walls using the comment section of wall elements, later this information is filtered in the Dynamo to eliminate top surfaces of parapet walls.

Selecting formwork elements and other elements are done with the input variables shown in Figure 3a. After running Dynamo, the algorithm gets the formwork elements and extracts all surfaces of each element. Meanwhile, the algorithm obtains the other categories and combines the element surfaces of these categories. Additionally, surfaces of the formwork category are also included in other elements to eliminate overlaps and intersections between the same elements. After that, formwork element surfaces are intersected with the surfaces of the other elements to eliminate intersections and overlaps of formwork elements by a surface difference operation. This operation provides formwork requiring surfaces for all structural categories. Then, side and sloped surfaces are filtered since they need to be formed in all structural categories, and top and bottom surfaces are investigated in a different path.

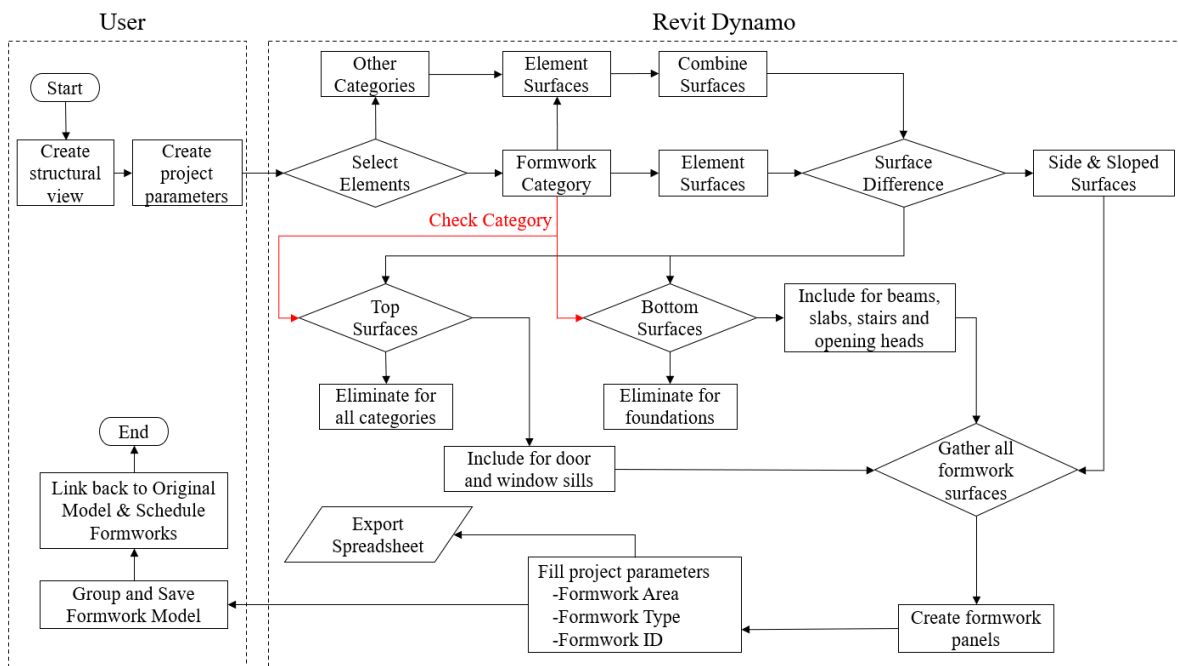


Fig. 2: Framework for the formwork area quantification and visualization

Since bottom surfaces are not formed in foundation elements, a boolean operation is performed to eliminate bottom surfaces for the foundation category. Hence, "is_foundation" is checked as true to calculate the formwork area of foundations while false is checked for the bottom of beams, slabs, stairs, and opening heads. It is important to note that the bottom surfaces of columns and walls are already eliminated in previous steps since they intersect with foundation and slab elements.

Top surfaces are first eliminated for all elements since the top of structures are not formed in the construction stage, but the bottom of the window and door openings in the wall category needs to be formed. Therefore, another boolean operation is implemented to filter door and window sills and include them into the calculation process by checking true under "is_wall" input, as shown in Figure 3a. Furthermore, the algorithm also examines the top surfaces for parapet walls, and it disregards top surfaces if they are part of parapet walls by filtering parapet walls using the "parapet" information inserted in previous stages. After manipulating top and bottom surfaces, they are gathered with side and sloped surfaces that are filtered in previous stages. These surfaces are

converted into generic formwork panels using the node obtained from the spring node library in Dynamo (see Figure 3c). The generic family template is imported from the Revit library by using the “file path” node in Figure 3a. Later, previously created project parameters for the generic model category are filled with formwork area, type, and ID information, and they are exported into a spreadsheet using the nodes shown in Figure 3b. After that, the formwork model is grouped and saved as a different Revit model. This model is also linked back to the original model, and formwork information is also scheduled in the software. This process is repeated for all structural categories.

The proposed method stores the element ID information, which is automatically generated by Autodesk Revit, and uses this information as formwork ID during the calculation. This way, formwork panels and areas could present the information of the structural elements which they belong to. Consequently, the proposed method classifies the formwork area information according to each structural element ID and it facilitates retrieving area information for individual building components.

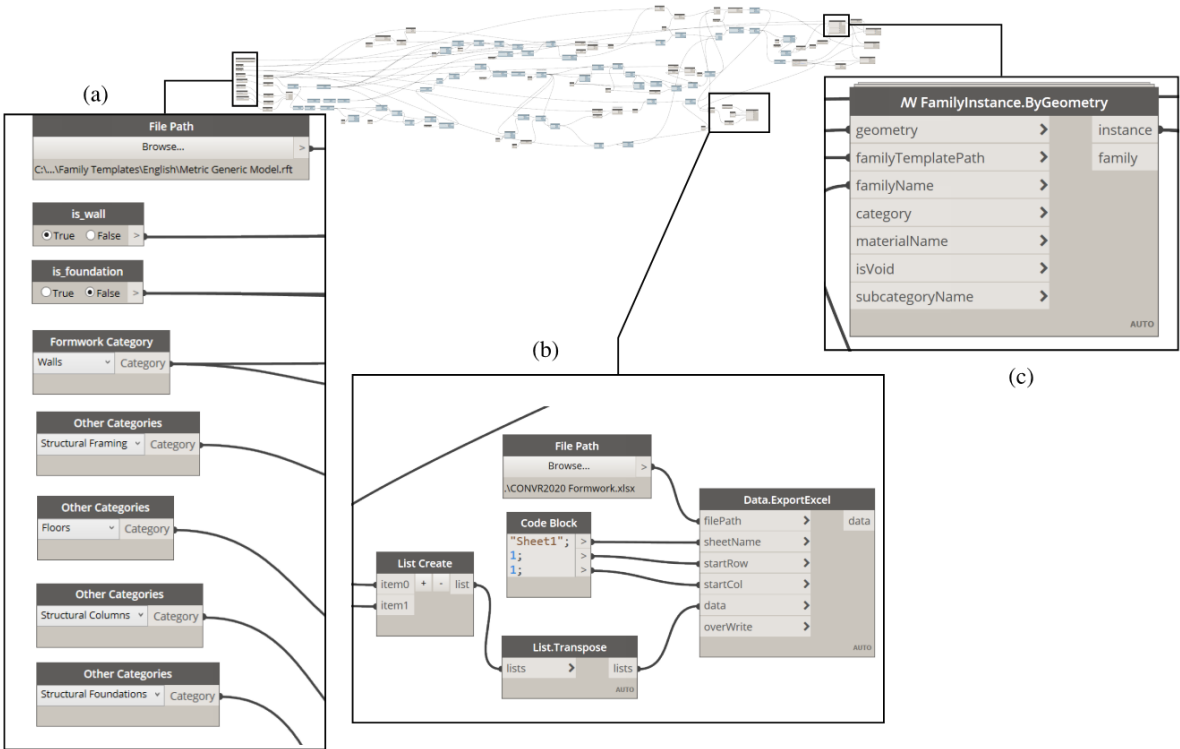


Fig. 3: View of visual code and essential nodes for the algorithm. (a) Nodes for input variables. (b) Nodes for spreadsheet creation. (c) Node for formwork panel generation

5. RESULTS AND DISCUSSIONS

This research aims to investigate the formwork quantification process in terms of accuracy and time. Since the building model is not an actual structure, there are no calculated quantities that can be used as a baseline for comparison of accuracy and time. Therefore, the manual quantity take-off area noted in Table 1 is calculated by manual measurement of beam and column formwork dimensions from the BIM model and manually splitting and painting of formwork requiring surfaces of foundations, slabs, walls, and stairs in the model. The reason for using two different approaches for different categories is because formwork area quantities obtained from Revit with *paint and split face* feature is known to be erroneous for beams and columns since intersections between elements cannot be split and painted. It is observed that using *paint* and *split face* features of the software make formwork area calculation possible and accurate for foundations, slabs, walls, and stair categories. Hence, formwork faces of these structural categories are split, where necessary, and then painted with a different material. After that, a material take-off schedule is created to extract the paint material, which is also the formwork area. Duration for splitting element faces and painting formwork surfaces are recorded, as shown in Table 1. Even though the software is utilized for take-off, the splitting and painting process took a significant amount of time when compared to the proposed automated method. This process cannot be shortened unless the splitting and painting tasks are automated since a user has to manually identify faces that need to be covered with formwork.

Beam and column areas, however, are calculated with measuring dimensions from the model and manually recording them in a spreadsheet since the Revit options mentioned above do not work for these elements. The time for the quantification process was again recorded and tabulated in Table 1. According to results shown in Table 1, the use of visual programming provides accurate formwork area information for all structural components investigated in this study. Besides, the duration for estimation was significantly reduced with this approach. Furthermore, Figure 4 shows the formwork model automatically created in Autodesk Revit environment with the proposed algorithm. Formwork elements are created by using generic family category, and area information, type of formwork, and formwork ID are included in each generic formwork element property with the help of project parameters assigned at the beginning of the process.

Table 1: Comparison of formwork quantity and duration between manual and automated processes

Formwork Elements	Manual Quantity Take-Off Area (m ²)	Manual Quantity Take-Off Time (s)	Automated Quantity Take-Off Area (m ²)	Automated Quantity Take-Off Time (s)	Deviations Area (%)
Foundations	262.45	04 min 11:44 s	262.45	01 min 07:36 s	0
Walls	2957.53	75 min 10:55 s	2957.53	08 min 45:77 s	0
Columns	558.22	110 min 05:26 s	558.22	06 min 28:32 s	0
Beams	580.36	90 min 08:13 s	580.36	07 min 44:55 s	0
Slabs	1375.59	31 min 55:43 s	1375.59	02 min 41:07 s	0
Stairs	93.90	20 min 45:36 s	93.90	07 min 39:45 s	0
Total	5828.05	332 min 17:37	5828.05	34 min 28:12 s	0

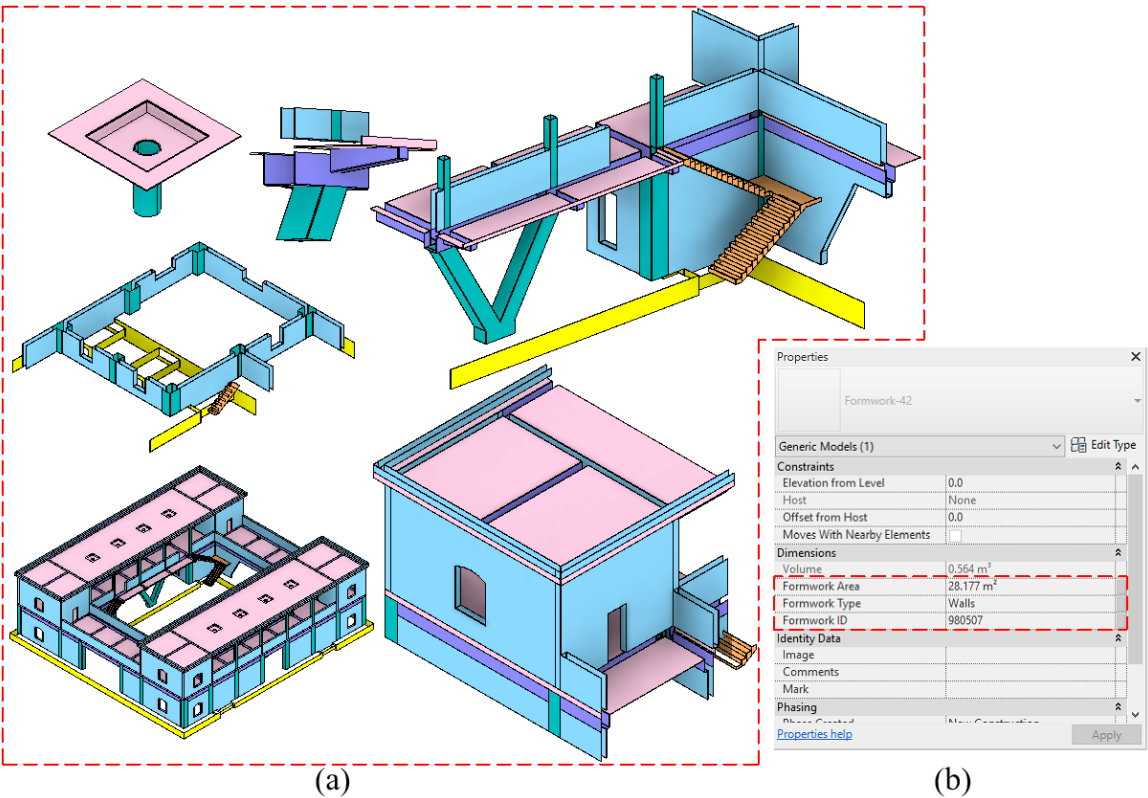


Fig. 4: (a) Visualization of formwork model and specific parts. (b) Automatically filled formwork properties.

The method is also tested with the IFC model of the same building, and new nodes, which are taken from the Dynamo bimorph nodes library, are incorporated into visual code to read IFC link information (see Figure 5). For this purpose, the building model created in Revit is exported to the IFC model, and this model is linked to a new project. After implementing new nodes into existing code, geometric information from the IFC model is read. Even though the formwork area for each structural group is precisely calculated, the formwork ID cannot be extracted from the IFC model. Hence, the algorithm needs to be improved, and it should also be investigated with different IFC models created in other modeling tools such as Tekla Structures and Allplan. Moreover, formwork quantification using different IFC platforms should also be studied in detail in order to enable a generic approach for automated QTO from all modeling tools.

It is verified that the proposed algorithm can calculate formwork areas accurately and faster than the current Revit based and spreadsheet approaches. Besides, a generic formwork model with valuable information can be generated by utilizing visual programming.

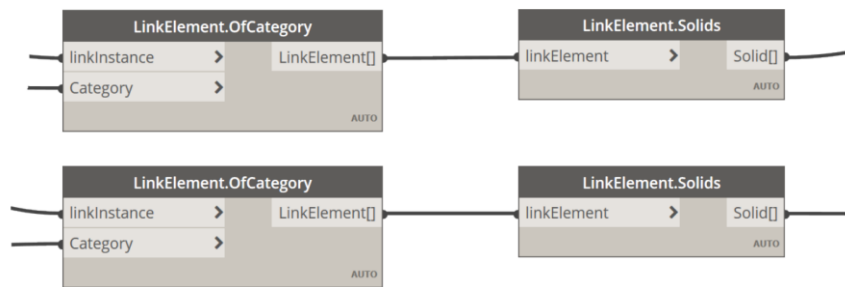


Fig. 5: Dynamo nodes used for reading IFC geometric information

6. CONCLUSION

Quantity take-off (QTO) using conventional 2D drawings is a time-consuming and tedious task. The use of BIM in the QTO process is not a straightforward process for area-based materials. Hence, this study focused on visual programming for formwork estimation and visualization of formwork panels by utilizing Autodesk Revit and IFC models. The visual coding aims to reduce the time for formwork quantification and increase the accuracy of BIM-based formwork QTO, which is usually obstructed by modeling mistakes and software limitations.

For this purpose, a reinforced concrete (RC) building is modeled, including tapered beams, slanted and circular columns, inclined wall surfaces, and arched and rectangular wall openings. Formwork quantities obtained from the modified model and the manual calculations and visual coding are compared in terms of time and accuracy. It is observed that formwork quantities are accurately extracted from Autodesk Revit models, and time is significantly reduced. With small modifications, the visual code is also applied to the IFC model extracted from the same Revit model, so that formwork quantification can be done utilizing open BIM standards. Accordingly, the total formwork area for different structural categories is calculated correctly, both using IFC and Revit models.

In future studies, the surfaces that are eliminated should also be classified according to element IDs so that the total eliminated area from the gross area of a structural element can also be determined and classified. Besides, the developed algorithm needs to be tested with real and more complex building models, including curved and faceted walls, to validate the proposed method for Revit and IFC models. Other types of RC structures, such as bridges and tunnels, should also be studied with the proposed method to test whether it can correctly calculate the formwork area. Furthermore, the creation of formwork elements is limited to the panel portion of the formwork assembly. Hence, further attempts need to be made for automatic modeling of the entire formwork system, including the actual amount of plywood that needs to be procured considering the waste, formwork supports, bracings, and cross beams to perform clash detection during the construction stage properly.

7. REFERENCES

Aram, S., Eastman, C., & Sacks, R. (2014, January). A knowledge-based framework for quantity takeoff and cost estimation in the AEC industry using BIM. In *The 31st International Symposium on Automation and Robotics in Construction and Mining* (p. 1).

- Ashcraft, H. W. (2008). Building Information Modeling: A framework for collaboration. *Construction Lawyer*, 28, 5.
- Bečvarovská, R., & Matějka, P. (2014). Comparative Analysis of Creating Traditional Quantity Takeoff Method and Using a BIM Tool. In *Construction Macroeconomics Conference 2014*.
- Cheung, F. K. T., Rihan, J., Tah, J., Duce, D., & Kurul, E. (2012). Early stage multi-level cost estimation for schematic BIM models. *Automation in Construction*, 27, 67–77.
- Cho, J., & Chun, J. (2015). Cost estimating methods for RC structures by quantity takeoff and quantity prediction in the design development stage. *Journal of Asian Architecture and Building Engineering*, 14(1), 65–72.
- Dynamo Bimorph Nodes, <https://bimorph.com/bimorph-nodes/>
- Dynamo Spring Nodes, <https://dynamonodes.com/category/springnodes/>
- Firat, C. E., Arditi, D., Hämäläinen, J. P., Stenstrand, J. and Kiiras, J. (2010). Quantity Take-off in Model-based Systems, In *Proceedings of the 27th CIB W78 International Conference*, Cairo, Egypt, 16–18.
- Kannan, R., & Santhi, H. (2013). Automated Construction Layout and Simulation of Concrete Formwork Systems Using Building Information Modeling. In *The 4th International Conference of European Asian Civil Engineering Forum (EACEF)*, Singapore, C7-C12.
- Khosakitchalert, C., Yabuki, N., & Fukuda, T. (2019a). Improving the accuracy of BIM-based quantity takeoff for compound elements. *Automation in Construction*, 106.
- Khosakitchalert, C., Yabuki, N., & Fukuda, T. (2019b). Automatic concrete formwork quantity takeoff using building information modeling. In *Proceedings of the 19th International Conference on Construction Applications of Virtual Reality (CONVR)*, 21–28.
- Lee, J., Park, Y. J., Choi, C. H., & Han, C. H. (2017). BIM-assisted labor productivity measurement method for structural formwork. *Automation in Construction*, 84, 121–132.
- Masood, R., Kharal, M. K. N., & Nasir, A. R. (2014). Is BIM adoption advantageous for construction industry of Pakistan? *Procedia Engineering*, 77, 229–238.
- Meadati, P., Irizarry, J., & Aknoukh, A. (2011). BIM and Concrete Formwork Repository. In *47th ASC Annual International Conference Proceedings*, Omaha, NE.
- Monteiro, A., & Martins, J. (2013). A survey on modeling guidelines for quantity takeoff-oriented BIM-based design. *Automation in Construction*, 35, 238–253.
- Olsen, D., & Taylor, J. M. (2017). Quantity Take-Off Using Building Information Modeling (BIM), and Its Limiting Factors. *Procedia Engineering*, 196, 1098–1105.
- Sabol, L. (2008). Challenges in Cost Estimating with Building Information Modeling. *Design and Construction Strategies*, 1-16.
- Shen, Z., & Issa, R. R. A. (2010). Quantitative evaluation of the BIM-assisted construction detailed cost estimates. *Journal of Information Technology in Construction*, 15, 234–257.
- Smith, P. (2014). BIM & the 5D Project Cost Manager. *Procedia - Social and Behavioral Sciences*, 119, 475–484.

DEVELOPING AN INTENSIONAL DEFINITION SATISFYING THE PHILOSOPHY OF DEFINITIONS TO APPRAISE THE THEORY OF BIM

Githyon Prabhu & Henry Abanda

Oxford Brookes University, United Kingdom.

ABSTRACT: *The construction industry has witnessed a surge in interest in the adoption of BIM. The surge has been matched with an awash definitions or descriptions for the terminology of BIM. As a result, many professionals with interests in adopting BIM are overwhelmed with these concepts, definitions and terminologies of BIM and cannot effectively use it. The research tackles the fundamental concepts deductively by employing analytical research while combining both qualitative and quantitative methods. NVivo qualitative analysis software was used to analyse axioms and gain insights, and Microsoft Excel was used for quantitative measures. The analysis has led to a definition for BIM with clear purpose, direction, and expressive completeness while meeting the necessary and sufficient conditions for its ease of understanding and application in practice.*

KEYWORDS: *BIM, Building, Information Modelling, Definition of BIM, Theory of BIM, Taxonomy of BIM, Future of BIM, Digital Twin.*

1. INTRODUCTION AND BACKGROUND

It is considered that BIM or *Building Information Modelling* is a paradigm shift in building sector during the last two decades. It is also noted that there is no fundamental change in approach or underlying principles existed for decades unless we try to present the idea as fresh (Bentley, Workman, & Laiserin, 2003). There are numerous definitions for BIM - relatively all documents explain what BIM is, in a way that leaves the readers to contemplate for a better definition Snook (2016) that include all the necessary and sufficient details. Till date, there is no widely accepted and context-independent definition for BIM. Definitions determine why, what, and how the fundamentals are applied in practice, policies, and research – the absence of a radical definition causes inconsistencies in these areas. However, almost all leaders globally have given up trying to define BIM (Snook, 2016). However, the gap persists and leaves the theorists, practitioners, and the initiatives to accept the term BIM simply as a label since the perception is that it does not communicate the underlying idea. The aim of this research is to re-establish the truth of BIM from its fundamentals rather than re-inventing the wheel once again by taking subverted supports to present the idea as fresh or giving appeal to buzzwords as happened in the past. Widespread opinion and consensus matters; however, the appraisal in this research is not based on their popularity but merit. The definition of a concept is simply the abstraction of its fundamentals which can be drafted in various levels of maturity.

Galle (Galle, 1995) has predicted the future of this field's literature as leading towards the dilemma, therefore, he suggested that the further research be conducted in a 'top-down', 'problem-driven' approach rather than the 'bottom-up', 'technology-driven' manner. This paper notes that his prediction was correct and the way he suggested to solve is meaningful; however, the literature has not stipulated the theory of BIM from the dilemma in 25 years in terms of investigating such problems and solving it. How one can stipulate something without addressing the necessary conditions as much as sufficient? And what it earns discovering the necessary and sufficient conditions or simply the fundamentals? *An Intensional Definition* and its theory is the answer, which if existed, a potential immunity from the dilemma, ambiguities, misalignments, and ignorance of fundamentals.

Associated General Contractors of America published a guide to BIM with a definition: "*Building Information Modeling is the development and use of a computer software model to simulate the construction and operation of a facility*" (AGC, 2005). National Institute of Building Sciences (NIBS) also published the *National Building Information Modeling Standard* with another definition: "*Building Information Modelling is the act of creating an electronic model of a facility...*" for a number of purposes. These definitions differ substantially in context and detail; however, they both matched in identifying the *model* as a product and making it model-centric. Since then, many guidelines, standards, protocols, templates, and as well as different definitions for BIM have been produced and promoted the implementation of BIM vigorously. The term BIM has undoubtedly galvanised the thinking and practice while communicated the common idea across disciplines (McPartland, 2017). Actually, these documents have also produced varying views, conflicting terminologies, and differing definitions (RIBA, 2012). There are aligning and opposing views of using the terminologies. Also, this study finds that a vigorous attempt is required to define BIM - the effort should consider the history, present trends and definitions, futuristic views of BIM, and respect the philosophy of definitions with a multidisciplinary problem-solving approach.

2. LITERATURE REVIEW

This section presents a part of the literature review as relevant to the definitions of BIM. The existing definitions and descriptions are also reviewed along with the opinions of industry experts in encouraging a universal definition for BIM. Moreover, the philosophy of definitions is studied and summarised to establish grounding qualifications. The other part of the review has covered the ideological background of BIM and continued with a detailed analysis of its history as ideological development, taxonomy, and the interdisciplinary position of BIM to tackle the issues at the right context.

2.1 Understanding the Issue, Suggestions, and Views

BIM is also a term which causes confusion than providing clarification, and it means different things to different people (CRC, 2009). The verbosity of three-letter terms creates confusions such as BIM is an acronym of many terminologies (Anderson, 2010). RIBA (2012) points out the issues with conflicting terminologies and differing definitions of BIM. Also, it has illustrated the importance of paying attention to the definition. Jurčević (2017) mentioned, "unfortunately, BIM still has no single, widely-accepted definition". According to Kubba (2017), BIM has failed to gain a widespread, consistent definition despite the widespread popularity. A number of UK BIM documents cover definitions of different BIM terminology (Jackson, 2013). Concerning BIM Dictionary, Jackson (2013) notes that BIM should have common terminology and standard definitions for the same thing across the industry, and this will surely be a logical step. And the same has been reiterated by Winfield (2015). A number of BIM standards did not use consistent definitions and signifies that the BIM terminology results in a number of shibboleths in a conflicting way (Ravenscroft, 2016). UKBIMA(Online) also illustrates that often the terminologies in BIM becomes the first barriers- its recommendation includes applying plain language, avoiding jargon, and using established abbreviations. However, systematic terminology-work requires intensional definition to resolve the lack of consensus among the lower ranking ostensive definitions and general descriptions.

While encouraging widely recognised definition for BIM on a context, Snook (Online) notes that "*we should invent another radically different definition*". Snook (2016) points out the ultimate goal of BIM, which supposed to be the *Sustainable Building* than temporal objectives. Also, BIM is a human activity that ultimately involves process changes in construction rather than being a think or software, and BIM should refer to *Building Information Modelling* the process than *Building Information Model* the product (Chuck. Eastman, Teicholz, Sacks, & Liston, 2008). The BIM Manager's Handbook by Holzer suggests that a semantic approach to any definitions for BIM is better left to the theorists. Snook (2016), referring to Albert Einstein, recommends that *BIM need to be defined as simple as possible but not simpler than possible*. It is suspected that the reason for not having an agreed definition for BIM could be the reason that BIM is evolving; however, how something would evolve in the right direction if not stipulated with a clear definition? International BIM implementation guide by RICS 2015 gives guidelines to define BIM better since there are confusions. According to this research, even those best available suggestions may limit the meaning of BIM instead of leveraging.

Mordue (2016) illustrates that the word *Building* should be considered as a verb. (Poljanšek, 2017) is focussing on three core actions for BIM: structuring, representing, and reporting. Jurčević (2017) calls BIM as a technology and an *intelligent simulation* of architecture that should include six key characteristics: digital, spatial and three dimensional, measurable and quantifiable, comprehensive or semantically relevant, accessible or interoperable or reliable, and usable in all phases of the facility.

BIM was expected as future, but NBS *National BIM Report 2018* report confirms that BIM is present since 2018. This report ends with a question: what is the future of BIM? And gives one answer - *the next BIM is BIM* – maybe it means that next comes the true BIM, and indicates that there could be other answers too. Allen (2017) challenges that "the future of BIM will not be BIM" by considering the integration of BIM with software algorithms in design, robotics in construction, and artificial intelligence. Allen (2017) indicates a number of potential terms to replace BIM - these terms include *Building Information Optimisation*, *Artificial Intelligence BIM or AI BIM*, and *AI BIM Plus*. The other set of futuristic views are about integration of BIM with the *Internet of Things* (Irmeler, Franz, & Rüppel, 2018) and *Semantic Web* (Abanda, Keivani, & Tah, 2013). NBS 10th Annual BIM Report 2020, is also suggesting to reduce focus from the label BIM and go beyond, as *Digital Twin* a next potential area of interest and many perceive this is a better alternative for the term BIM. However, full awareness of differences, relationships, and fundamentals of these paradigms is the only way to predict the future of BIM well. The profound extent of *Information Modelling* must be capable of handling all of these futuristic views in BIM without altering its name, theory, and fundamentals unless we confuse it.

2.2 Understanding the Definitions for BIM

The research has also studied on different terminologies and phrasal used in different time periods, referring this idea as BIM evolved. However, this section will focus on different descriptions or definitions that are used to describe BIM in part or full while acknowledging that all definitions studied were not originally developed with the intention of defining BIM fully and accurately. This review encountered aligning and opposing views with the aid of constant comparative technique and helped to understand the problem and the potential solutions better.

Autodesk (2002) introduced *Building Information Modelling* as the "application of information technology to the building industry" with three characteristics: firstly, creates and operates the digital databases for collaboration, secondly, manages the changes in databases and updates in all parts of the database as real-time coordination, and finally, it captures and preserves *Information* for the re-use in more applications. BIM was told as another generation of *software solutions* beyond the abilities of existed *Object-Oriented CAD systems* (Autodesk, 2002) the outcomes of the solutions were clearly explained to the audience of building industry. However, the mechanism of the new *software solutions* was not explained with the perspective of *Computer Science*.

The letter 'B' in BIM that stands for *Building* was better explained in the literature for BDS (C. Eastman, 1973) as *spatial compositions* and clarified as a physical system or artefact refers to buildings, ships and machines, that are made up of a three-dimensional component and in which spatial arrangement is a significant concern (Charles. Eastman & Henrion, 1977). However, the latest understanding of *Building* in BIM is quite narrow and refers only to the *buildings and civil works* (ISO 19650-1, 2018). The letter 'I' that stands for *Information* has been treated as the most important part of BIM. The model was explained as the database encompasses all physical and other characteristics of buildings. Also, the early discussions were concerned about differences between visualisation, simulation, and representation in BIM (Laiserin, 2002). However, the importance and the depth of the letter 'M' that stands for *Modelling* also was understood well in the early days (Barron & Laiserin, 2003) - Barron argued that the *Information* stands everywhere in the application of BIM and Laiserin responded that the *Modelling* endures as a necessary precondition of having BIM. However, vigorous attention was given only to the letter 'I' until these days, and the meaning of *Modelling* in BIM has been marginalised as 3D modelling.

Earliest definitions for BIM defined both *Building Information Model* and the *Building Information Modelling*. The former relates to the *Object-Oriented intelligent parametric digital representation of a facility*, and the latter is about the *simulation of construction and operation using the computer software model* (AGC, 2005). The connection between these definitions is not clear. NIBS (2007) also included two definitions of BIM. *Building Information Model* was defined as "a digital representation of physical and functional characteristics of a facility". Significantly, this takes note of AGC (2005) definition but adds more detail about what exactly the *representation* includes - *physical and functional characteristics*; however, it has omitted the phrase *Object-Oriented*. *Building Information Modelling* was defined as "the act of creating an electronic model of a facility" (NIBS, 2007); this definition is different from AGC (2005). The definition by NIBS (2007) has omitted the expression 'use' and fixed the gap by creating another phrasal - *Building Information Management - the business structures of work and communication that enhances the quality and efficiency*. The idea of *BIG BIM* and *little bim* was another way that explained BIM. *BIG BIM* is about the management of *Information*, complexity, relationships, collaboration. *Little bim* is about the focus on software tool capabilities and usage in isolation (Jernigan, 2007). Apparently, *BIG BIM* matches the previous description of *Building Information Management or use*. BIM was defined as the 'human activity' to 'create and use' in a *Building Information Model*; however, the activity is enabled by using software, hardware, and technologies (Jernigan, 2007 cited in ASHRAE, 2009). Here, one may realise that the industry has ignored the importance of *Modelling* - at least in the part of *using the models*, where using *models* will not be possible without the continual function of *Modelling*.

Building Information Modelling was defined as *the development and use of a multi-faceted computer software data model to document a building design, to simulate the construction and operation of a facility* (GSA, 2007). Here, the definition possibly combines both AGC (2005) and NIBS (2007) definitions; however, the difference here is in the phrase *software data model*. Davis (2007) explained BIM as *the representation of a product, and the digital deliverable of aggregated Data or Information to support simulation and analysis*. 'Aggregation of information' is notable; however, what makes the aggregation of *Information* was not addressed. AIA (2007) describes BIM as "a digital, three-dimensional model linked to a database of project information"; here, the 3D model and the *Information* are pictured separately but with a link.

National Guidelines for Digital Modelling (CRC, 2009) notes that people make different meanings out of BIM, and thus did not develop another definition. However, CRC (2009) describes that "it must be a three-dimensional

representation of the facility that has parts or objects, and it must include some information additionally about the objects beyond the graphical representation." This approves the simplest form of graphical three-dimensional objects with minimal non-graphical data as BIM. Also, CRC (2009) believes that the 'two-dimensional models' or something without non-graphical data should not qualify as BIM. This description aligns with the mainstream idea. Moreover, definitions by CRC (2009) and AIA (2007) looks similar, but there are fundamental differences. For AIA (2007) the three-dimensional *model should have database connectivity*, but CRC (2009) expects the *model to have data inherently*.

Triton College (2009) notes BIM as *"a model-based technology connected to the database of project information used to create a digital representation of the building process to facilitate exchange and interoperability of Information in digital format. BIM addresses geometry, spatial relationships"*. Here, differences are: *facilitating exchange, interoperability*, and the technicality of relationship. Jernigan (2007) has already noted the *relationships*, but here it narrows to the *spatial relationship*. BSI (2010) notes BIM as the *"digital representation of the physical and functional characteristics of a building over its life cycle"*. This definition is missing the conditions by (CRC, 2009). In this, the *digital representation* can be anything, even a picture - this is deflationism in the philosophy of expressions. Besides, what if the *representation* goes dynamic and qualifies into the *simulation*?

The software developers have also produced definitions. As presented in a study (Vogt, 2010), Graphisoft calls BIM as *a single repository of graphical, non-graphical, and other data*. Autodesk calls BIM as *a methodology for building design and documentation that is characterised by the creation and use of coordinated, consistent, and computable information about a building project*. Bentley calls BIM as *Modelling of graphical and non-graphical aspects of the building's entire lifecycle in a federated database management system*. In this collection, BIM can be a methodology, single repository, or *Modelling*. Significantly, Bentley stayed firm on their first-cut-view and vision on BIM, which is 'beyond CAD' but *Modelling* - without re-inventing the wheel (Bentley et al., 2003). Anyhow, CAD includes *Modelling* already, and it can be 1D or 2D or 3D.

Veterans Affairs (VA, 2010) defines *Building Information Management* as supporting the standards and requirements for BIM use and ensuring the continuity of data, a reliable exchange that retains the *Information* in context. Also, *Building Information Modelling* is defined as *"a collection of defined model uses, workflows, and modelling methods used to achieve specific, repeatable, and reliable information results from the model"*. Later, VA (2016) adopted the definition for *Building Information Model* by NIBS (2007) and applied it for both *Building Information Model and Modelling*. *Building Information Modelling* is often referring to the acronym BIM, and it is a process improvement methodology leveraging the data in analysis and in predicting outcomes throughout the *Building* lifecycle (Reddy, 2011). Moreover, BIM is a database-driven representation of the building throughout the lifecycle, the 3D is important, but only a small part of its capability (Reddy, 2011). This idea matches with earlier ones but signifies a capability of BIM. As such, Models are not just the structured form of static representation of data or *Information*, but it comes with the inherent potential to produce more.

According to National Home Builders Association - NHBA (2011) *Building Information Model* is the *Information* enhanced geometric model of one or more objects having relations to others. Also, *Building Information Modelling* was defined as the process of constructing or creating the *Building Information Model*. None of the earlier definitions has explicitly stated this but repeated later in AIA (2013). *Building Information Management* was defined as the *'resource and information management'* of a project process grounded in *BIM technology and methodology* (NHBA, 2011). Here, the expression *BIM technology and methodology* is added; this may produce circular references with the idea of BIM as a process.

NBS (2011) described *Building Information Model* as *"a rich' information model', consisting of potentially multiple data sources, elements of which can be shared across all stakeholders and be maintained across the life of a building from inception to recycling. The 'information model' can include contract and specification properties, personnel, programming, quantities, cost, spaces and geometry"*. This definition makes a significant difference - the *'information model'* is used in place of *'digital representation'*, and allows potential usages and the possibility of inclusion of conditions rather than forcing towards holistic dogma. NBS (2011) makes a difference from VA (2010) by removing the compulsion of pre-defined usage without contradicting the benefits if pre-defined. Also, NBS (2011) presented the user expression of BIM, where, *"Building Information Modelling is the process of creating and using electronic data models of buildings."* At this point, it is crucial to recall earlier definitions, AGC (2005) for *computer software model*, NIBS (2007) for *electronic model*, and (GSA, 2007) for *software data model* to confirm the dilemma in BIM as predicted by Glalle (1995).

Eastman *et al.*, (2011) nails BIM as an activity or a process rather than an object or product. Also, Eastman *et al.*,

(2011) note that BIM describes the tools, processes, and the technologies; however, the relationship of tools and technologies with BIM the process is not clear. The connecting mechanism is potentially *Modelling*.

ISO/TS 12911 (2012) defines BIM as *a process of managing the Information*. If so, why another term called *Information Management*? However, vigorous attention has been given to term *Information Management* since 2013 with the perception of *using BIM for Information Management*. The outline for the scope of the role of *Information Management* was published by Construction Industry Council (CIC), but with a definition for *Information Model* which is about "all documentation, non-graphical information and graphical information which the project team is required to provide" or deliver (CIC, 2013). Notably, NBS (2011) described the *Information Model* with free to choose potentials; here, compelling conditions are presented to upkeep the scope for *Information Management*, and make it appear contemporary by using BIM. BSI PAS 1192-2 shows the *Information Management* and BIM as two but closely related things. According to BIM for the terrified: a guide for manufacturers by CPA, *Building Information Modelling* is the process of managing the *Information*, in a common format, produced during the lifecycle of the project. Here, both *Information Management* and BIM ended up having the same meaning.

"*Building Information Modelling is the activity undertaken to create the model, other data, both internal and external, and the meaningful relationships between the model and data*" (CANBIM, 2014). Also, it refers *Building Information Management(BIM) to the activity of keeping the BIM aligned with standards and uses* (CANBIM, 2014); apparently, this derives another *BIM to manage BIM* rather than calling it a *BIM Management*. BSI PAS 1192-5 defines *Building Information Modelling* as a way it describes only product use. ISO 16757-1 (2015) describes BIM as, "*Construction of a model that contains the information about a building from all phases of the building life cycle*" in a way it ignores the use. Here, the ambiguities and dilemma are explicit.

NIBS (2015) maintained its earlier definition for *Building Information Model* from 2007; however, modified its definition for *Building Information Modelling* as a business process for generating and leveraging the building data to conduct activities during the building lifecycle. *Building Information Management* was also re-defined as the organisation and control of the business process that utilises the *Information* during the lifecycle of the building (NIBS, 2015). The phrase *business process* could refer a standardised start to finish workflow in a repeatable manner with limited choices for user decisions. The term *Building Information Modelling* can handle the *Business Process* by managing the *Information*. Winfield (2015) presented a definition: "*BIM is the process of generating and managing the Information about a building during its entire lifecycle. BIM is a suite of technologies and processes that integrate to form the System at the heart of which is a component-based 3D representation of each building element*". Again, this clarifies the sufficiency of BIM to generate, use and manage the *Information* within. *Building Information Model* was defined as "*the shared digital representation of the physical and functional characteristics of any construction works*" (ISO 29481-1, 2016). 'Any construction works' should mean more than just the buildings, if so, it matches with Eastman and Henrion (1977) and arguably contradicts with ISO 19650-1 (2018). *Building Information Modelling* is defined as the 'use' of shared digital representation of a built object to perform the lifecycle activities such as design, construction, and operation (ISO 29481-1, 2016); however, the solitary expression of 'use' does not make expressive completeness for BIM.

Bond Bryan BIM Dictionary (Jackson et al., 2016) presents the definitions for *Building Information Modelling*. It treats *BIM* as *Information Management* which is defined as the "*means measures that protect and defend information and information systems concerning their availability, integrity, authentication, confidentiality, and nonrepudiation*". However, this definition should have been given to CDE unless BIM is seamlessly integrated with CDE as a Connected Data Environment. Moreover, "*BIM is a process for creating, and managing information on a construction project across the project lifecycle*" (McPartland, 2017); this could mean that the term BIM inherently includes the scope of *Building Information Management*. Collectively, calling *Building Information Management* as BIM has produced confusion at least with CDE. BIM is described as a process or method of managing *Information* using the shared digital representations of physical and functional characteristics of any built object according to EUBIM Handbook. All these again confirm the sufficiency of the term BIM and modelling to handle *Information Management* within.

Besides NIBS (2015), ISO 19650-1 (2018) also sets out the principles for *business processes* in support of the management producing information during the life cycle of built assets when using BIM and calls it as *Information Management*. Here, ISO 19650-1 (2018) and NIBS (2015) could work perfectly together if BIM is understood as an evolved way of *Information Management* in the business processes. However, the 3D model has been noted as a necessary precondition for BIM. BIM is an intelligent model-based process (Green, 2016), and according to Mordue (2016), BIM is a process which involves creating and using an intelligent 3D model. Also, the *Building*

Information Model firstly to be visualised as virtually representing the geometry of the real asset, and be capable of reporting object properties and relationships. Should a geometric 3d model be a compelling condition for the *Modelling of Information* of all business processes in *Building*? If yes, will it be pragmatic to be called as evolved way of *Information Management* in support of business processes? If no, why it is called as *Information Management* in place of *Information Modelling*? If yes, it can envisage the *Information Modelling* with augmented or mixed reality where the geometric 3D can be replaced with real word objects at a given stage of information lifecycle, and therefore the *Information* can be modelled separately while being *Semantically Connectable* to 3d geometric *Modelling* and/or real-world objects. This proves the ability of the term *Information Modelling* to accommodate the terms *Digital Twin* and *Digital Thread* within regardless of its application domain such as *Building* or Aeronautical; respectively, BIM can accommodate the term Digital Twin in referring *Building* as a phenomenon. On the other hand, identifying BIM as representation is not accurate than calling it a simulation – where simulation means both modelling and replica – simulation is a quasi-synonym to representation.

2.3 Understanding the Philosophy of Definitions and Logics

When it comes to the definition of terminologies that relates to revolutions in human undertakings, we are in the downside of mastering both technical and philosophical aspects to appreciate these advancements (Cook, 2009) properly. Definition of the definition is "the condition of being definite, distinct, or clearly outlined" according to dictionary.com. *A Dictionary of Philosophical Logic* (Cook, 2009) gives a good basis for the understanding of such critical knowledge, some of them are summarised in this section. Humans have the inability to provide definitions instantly to all but identifying the most circumscribed of concepts; therefore, the definitions end up producing something like a rough-and-ready description (Crumley, 2006). The idea of pursuing core understanding or definition-ism comes from "*taking the chance to address the necessary and sufficient conditions*"; However, the identification of conditions builds with those early descriptions or axioms (Crumley, 2006). The knowledge needs to be applied in context-independent and the context-dependent settings (El-Diraby, 2012), this awareness is critical to deal with a complex phenomenon such as BIM.

Theorists need to use both technical and philosophical sense in drawing definitions (Cook, 2009). *Intensional logic* is about different expressions with absolute different meanings; however, they provide the semantic relationship with the expressions that are related. *Intensional Definition* gives the meaning of an expression by specifying necessary and sufficient conditions for the correct application of the terms with *extensional definitions*. *Extensional definitions* are the definitions for the conditions outlined in the *Intensional Definition*. *Ostensive Definitions* conveys the meaning by using examples directly or indirectly without attempting to present the whole logic. Almost all of the existing definitions for BIM can be categorised as *Ostensive Definitions*. *Ostensive definitions* vary to its use cases and may seem lacking consensus. *Intensional Definition* shows the highest level of abstraction maturity of a concept and becomes a benchmark for the concept to further evolve. Contradictions come true, or the semantics fail if not provided with *counter necessary statements* to deal with paradoxes in 'impossible world' cases. *Expressive completeness* is a set of rational connectives of the associated truth functions sensitively complete only if all the given features being expressed by some combination of those connectives. Harmonisation of a concept, term, and definition helps to define closely related or consequential matters without duplication.

Deflationism refers to the truth in different views, but its thesis evokes that the truth is not a substantial concept, and an assertion sets the truth on a statement which does not ascribe anything. *Stipulative expressions* provide a novel meaning for an existing expression using the pre-existing meanings, and in effect, it may provide a new expression or re-establish the ignored ones. *Circularities* in definitions are fallacies; apparently, definitions may include circularity in pragmatism. However, circularity creates symbol grounding problem in the usage of language, especially where *Computer Science* is applied (Harnad, 1990). In definitions, the words may produce muddles under different conditions such as *capitonym*, *homonym* or *polysemy*, *synonym*, *quasi-synonym*, and *oronym*' (Hurford & Heasley, 1983). The expressions are written and read differently but provide similar meanings in varying degree in the case of quasi-synonyms, such as representation and simulation which are not interchangeable. In homonym and polysemy, the same word has closely related but different meanings such as model.

Stephen's Guide to the Logical Fallacies of 1996 by Stephen Downes gives extensive knowledge about the fallacies that may occur in expressions or definitions. Also, the fallacies come in a broad range that includes fallacies of distraction such as false dilemma and ignorance, appeal to motives for popularity or consequences, subject change such as appeal to authority or being authoritative, missing the point such as straw man approach, fallacies of ambiguity, non-sequitur fallacies such as affirming the consequences and denying the antecedents or enablers, fallacies of explanation such as subverted support where the problem being explained does not exist, and finally the fallacies of definitions. Even the definitions may produce fallacies without being influenced by the logic.

Fallacies of the definition include being too broad, too narrow, failure to clarify, circularity and circular definitions, and conflicting conditions. Requirement of terminology works include ISO 704-2009 and ISO 1087-2019.

3. RESEARCH METHOD

This study comes under the fundamentals research type tackling the concept and the logic of the research matter in a way that influences the applications and further research. This study combines both qualitative and quantitative methods in an analytical framework that deductively refines the subject idea with a top-down approach. This research deals with the history of the subject matter, collection of axioms, and philosophy of expressions and definitions. The multidisciplinary problem-solving has been equipped with a constant comparative technique. Table.1 presents the research design indicating the top-down approach. This paper and the research framework present only the second part of the research. The earlier part was bottom-up inductive on the same analytical base. The methodology in the earlier part covered the data collection, dealing with epistemology, etymology, and futurology of the concept towards scrutinising and generalising the idea. This part shows how the research was continued after generalising the idea. Establishing the context, observing patterns, and scrutinising the details are steps utilised to allow the fundamentals to define the concept of BIM.

Table 1: Research Framework

Review of Literature (Analytical Basis)	Analytical Research (Deductive Top-down Approach)	
History	○	Generalise the Idea
Axioms	↓	Establish the Context
Possibilities	↓	Observe Patterns
Philosophy in Context	↓	Scrutinise Details
Problem Solving	●	Define the Idea

The research method undertakes an extensive literature review on the analytical base to constantly compare the movement of the underlying idea observing changes in expression to gain insights from it. A qualitative analysis using Nvivo Software has been carried out to understand the patterns with the use of data analysis functions such as word frequency cloud and relationship word-tree. Several definitions and leading BIM documents have been analysed and the research has collected a number of defining conditions and then finalised with a deductive selection iteratively. However, the expressive completeness was measured quantitatively and iteratively using the Microsoft Excel spreadsheet to guarantee the sufficiency and necessity of the conditions as they draw a definition for BIM. The next section presents the samples of analysis.

The earlier part of the research has established the validity of the terminology; this part presents the defining fundamentals in a standardised manner satisfying the requirements of terminology works. The definition is the abstraction of its fundamentals: therefore, the research on fundamentals collect all possible defining conditions. The comprehensive selection of these conditions could not include all the opinions available in the concept field to meet the requirements for *Intensional Definition* concerning sufficiency and fallacies.

4. DISCUSSION AND RESULTS

The development of the new definition is enabled by an extensive review of the literature to recognise the existing truth. Qualitative data analysis using Nvivo Software to understand the patterns. Analytic based selection and deduction of conditions that define BIM, and finally, the spreadsheet-based quantitative observations in iterations until reaching the best possible results. The review of the literature reveals that the literature is diverse and mostly inconsistent. BIM is given with different names to find a satisfying terminology name with new definitions; however, they limit the meaning of BIM and create confusions. BIM is noted consistently as representation; while it is true, challenged to go further as *Simulation*. The literature treats BIM as *Information-centric*; however, it has been challenged as *Modelling-centric*. None of the existing definitions could make expressive completeness due to the fallacies according to the philosophy of definitions, thus categorised as useful but ostensive definitions in

their contexts. The existing definitions fail to elucidate the context, contribution, significance, direction, and the ultimate purpose. Moreover, it becomes clear that the fundamental characteristics of *Information Modelling* are generally misunderstood or poorly conceptualised in BIM.

Vigorous attention is needed to stipulate the terminologies *Building* and *Modelling* than *Information*. *Information* in BIM represents the position of humans between *Building* and *Modelling* because humans need *Information*, and BIM provides it with the function of *Modelling*. Machines need data and *Models*, and machines use them with the function of *Modelling*. To further illuminate the idea of BIM, the extensional meaning of the terminology '*Modelling*' in the context of BIM is addressed. The Intensional Definition is analysed quantitatively and proves the findings of this study over the existing definitions for BIM. While it remains true that the *Model* and *Modelling* refers to 3d shape or geometry, it is only a portion of *Modelling* and a small part of *Information Modelling*.

Today's BIM has been confused as a technology or a methodology or a man-machine collaboration, or management. However, most of them agree that BIM is a process and BIM does not come in a box. BIM is enabled by technologies, machines, methodologies, standardisations, managements, and principles. Technology, in general, enhances everything and anything in life and business. But, technology enables BIM by creating technological machines. The technology and machines enable methodologies, methodologies in BIM are as basic as input, output, and method of *Modelling*, then modelling languages, complex analysis and simulations, display methods and virtual experiences, and finally the high-level methodologies in business cases, implementation, and management. However, standardisations, managements and principles at governance are evidently present in both technology, machines, and methodologies. As such, one may understand not to confuse between the enablers of BIM the process in order to avoid a non-sequitur fallacy. BIM comes in levels of processes - the processes are present in both enablers and in results; however, it may confuse initially, but it is truly the reason that BIM should be synthesised and globally agreed as a *process*.

Theorists have ignored the importance of differences in terms such as *Computing*, *Information*, and *Model or Modelling*. The information-centric theories, while it remains essential, have been blinded by the view of Informatics which means 'information and automatic'. This is a fundamental reason for the confusions that are experienced in the industries applying computer science such as BIM. While the technology experienced today is truly a wonder, this study disagrees with bare views of handling *Information* automatically, or magically or miraculously. As such, the usage of the word automatic is a downfall in literature. Therefore, the theories must be specific on what makes the automation. In BIM, *Modelling* of data and *Information* makes automation; however, with algorithms, the automation goes further and intelligent. Therefore, it is *Information Modelling*' not merely informatics. Dilemma and ignorance cause fallacies of distraction in logics and definitions (Downes, 1996). Consequently, it suggests having an increasing focus on the term *Information Modelling* as a taxonomy for BIM.

The modern principle of building lifecycle is about *building sustainably* according to green building initiatives (Kubba, 2017) and BIM plays a major role in green building. But apparently, why humans do BIM ultimately is a serious question, and there could not be an ultimate answer than the noble motive to build sustainably. Now, the building lifecycle involving BIM is about humans collectively and their motivation to build sustainably. Therefore, the definition of BIM needs to express this ultimate purpose.

BIM relates both business and life in the lifecycle of *Building*. Data is everywhere, but the *Information* exists only if the *Modelling* exists. *Information* is about the readability of humans, *data* is about the readability of machines, and the models are about the workability of both human and machines. For machines, all of them are data and models in different forms. Intelligent autonomous machines need data and models in different forms and patterns, but they generalise models using the function of *Modelling* and produce real-world applications.

Moreover, the *Information* favours the human comprehensions, but the technology is reaching to interact with human cognition with the integration of data. This idea is called *Datafication*, and this study brings this idea to BIM as *datafied business and life*. Datafication comes to happen and already is present in a sense. For example, *IoT*, *Artificial Intelligence*, and the *Digital Twins and Threads* at the information level. A smartwatch alerts labour from a safety hazard with a specific and trained code of vibration is a possible example for cognition. However, if future, the biotechnology will advance and help humans to advance into techno-social entities. Therefore, the definition of BIM needs to express this direction since the future demands BIM to be capable. BIM is *Information Modelling*, which is a meta-modelling construct of *Data Modelling*. *Information* supports human interpretations, and data helps the machines to recognise and handle the models at any level of meta-modelling. Therefore, futuristically concerning both humans and machines, the definitions of BIM need to signify the *Modelling* of both *Data* and *Information*. This research borrows the term *Datafication* into BIM from its taxonomy parents to

substantiate the higher level of *Datafication from Digitisation*.

The concept of metamodelling is essential to the technicality of BIM. The metamodel is explained as the model of models and this needed to be understood from a very basic level of metamodelling with the concept of shape models having extended object models as originally explained by Eastman and Henion (1977). NIBS (2007) has provided some examples of metamodelling in BIM. The term multi-model is also used in response to the exchange and provision of interdisciplinary information leveraging sophisticated cross-domain BIM applications such as energy modelling (Fuchs & Scherer, 2017). Metamodelling is an essential function in *Information Modelling*, and therefore, models from different specialities may get added to BIM. As a simple example of metamodeling can be 4D or Energy Analysis or Connecting IoT data to the existing models to produce *Digital Twins*.

Moreover, the intelligence created by algorithms in machines is known as *Artificial Intelligence*, where it enables and enhances problem-solving and decision making on its execution to complete the programmed task. The computers are full of algorithms; however, again in the case of BIM, algorithms help to automate the modelling tasks and output functions towards achieving the given goals in workflows within the construct of *Modelling*. AI algorithms learn from earlier executions; *Artificial Intelligence* or AI is only a part of the intelligence created by the algorithms. The other famous one could be the *generative algorithms* helping to generate possibilities of solutions and generate the solutions effectively as preferred with reduced human effort. The concept of *Generative Design* is an example. This research realises that the intelligence that created by the algorithms need to be expressed sufficiently well in the definition for BIM to avoid fallacies of distraction.

BIM is enabled by its enablers in context; however, BIM itself enables, enhances, and integrates a number of activities in *Building*. The indefinite list of activities includes design, quantity estimation, construction programming, visualisation, construction, and even *Information Management*. These activities, in different disciplines, but in collaboration, define the immediate purpose of BIM. Both enabling and enhancing of the activities integrate seamlessly, and integration also is a separate collaborative action.

The Semantic relationship is vital in linguistics and human communication of *Information*, and pivotal while involving machines. The correctness, consistency, accessibility, and control are the keys to semantics in BIM. Therefore, such characteristics of the semantics were addressed as *Semantic Integrity* (C. M. Eastman, 1981; Galle, 1995). This fundamental of BIM has been ignored to date, thus limits the expressions of BIM. Therefore, *Semantic Integrity* must be stipulated.

Collaboration is fundamental in BIM; however, only a few authors presently see *collaboration* as a terminology in the context of BIM. Collaboration between the machines, between the models or model objects, between humans while undertaking the actions or tasks, and the collaboration of all – are closely and inevitably related and holistically connected in BIM. *Collaboration* is a noun that already means collaborative action. The task or action by machines or humans is pivotal in BIM; however, the action without a holistic *collaboration* means nothing in BIM. Even a simple *Modelling* function already showcases a high level of *collaboration* with its enablers and outcomes. Therefore, the term BIM needs to be expressed with significance to *Collaborative Action*.

The purpose-built assets make facilities during its use. Generally, a number of smaller assets composite a larger asset, as such, asset includes parts in different levels. Assets can be movable or immovable and may refer to a facility or might be found in a facility. *Product Information Modelling* deals with assets, so does BIM deals with assets collaboratively hand in hand. However, how assets put together or being built makes a facility of given purpose in aggregation. Assets in BIM can be physical or intellectual but experienced as composition in real or virtual space even without compelling on 3D. The compositions in virtual or real space need to hold the knowledge and application of building in a way it connects to the knowledge lifecycle of *Building* to qualify into BIM. BIM deals with assets, assets beyond the level of being physical or a facility; therefore, the context-free expression of BIM may choose the word asset with the significance of relating *spatial compositions* than a *facility*.

The development of an intensional definition for BIM is the result of the top-down deductive selection of defining conditions. The research has analysed more than 75 definitions for BIM qualitatively and quantitatively. Using Nvivo qualitative analysis software, the present idea of BIM has been synthesised. In particular, the software produced word-cloud and word-tree visualisations to understand the trends and connections. As an example from many, Fig.1 shows how the research has revisited the term simulation. Also, Fig.2 is an example of the word-clouds that helped to realise how predominantly the BIM is accepted as a process opposed as a product, thus sought to provide a solution in using acronyms without encouraging a parallel definition to avoid mix-ups. The basis of this solution is not just the widespread opinion but the harmonisation of the concept, term, and its definition - both shall not be defined in parallel since they are consequential to each other.

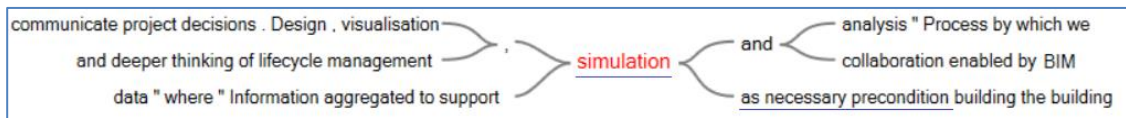


Fig.1: Example for word-tree

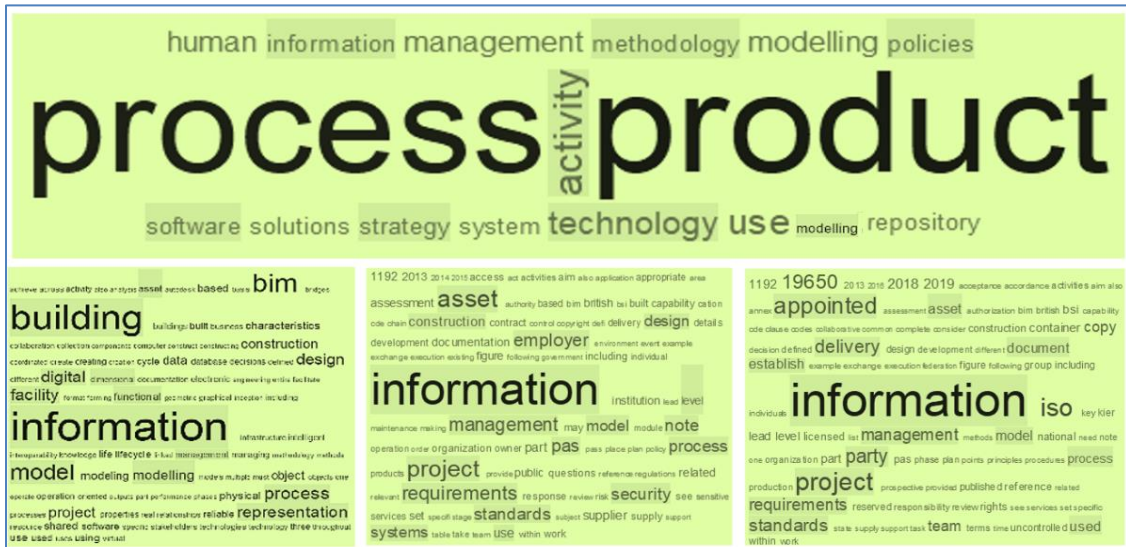


Fig.2: Example for word-cloud

The insights include the understanding of missing parts in various definitions and documents, inconsistencies, the existence of unnecessary and confusing or conflicting conditions and the potential improvements, as a result. The research has developed a number of necessary and limiting conditions iteratively. The necessary conditions refer to the fundamentals identified from the existing data with the help of review and analytic tools. The limiting conditions or the fallacies are based on the fallacies noted within the analysed definitions and ideological evolution. It is clear that *Information* is isolated from its full terminology *Information Modelling* and *Modelling* is absent.

The finalised necessary conditions are: **Technology as enabler**, **Machine as enabler**, **Methodology as enabler**, **Standardisation as enabler**, **Management as enabler**, **Principles as enabler**, **Done in Digital or Electronic or Virtual**, **Taxonomy of applied domain addressed**, **An application of Computer Science**, **Generalised purpose**, **Building non-industry specific but verb**, **Building as Lifecycle**, **Building as a phenomenon**, **Ultimate Purpose of BIM**, **Direction of BIM**, **BIM is Process**, **Process of Modelling**, **Modelling in context**, **Modelling levels or layers addressed**, **Objects addressed in computer ontology**, **Textual or non-graphical models**, **Dimensional, geometrical shape modelling**, **Shape modelling over space models**, **Graphical models**, **Modelling of relationships**, **Classification of Objects**, **Construct essence of objects or models**, **Modelling of functions and process-based actions**, **Modelling in Simulation**, **Intelligent Modelling**, **Intelligence by Algorithms**, **Semantic Integrity**, **Collaboration**, **Task Based or Action**, **Actions on Activities**, **Actions to Enable Activities**, **Actions to Enhance Activities**, **Actions to Integrate activities**, **Significance of the actions in BIM**, **Significance of the assets in BIM**, **Expressive Completeness**, **Beyond the life of assets**, **Beyond a better alternative for CAD**, **Distinct from CAD or GIS or BMS or etc.**, **Avoid conflicts with terminologies**, **Defines the scope without limiting**, **Allow smallest and the greatest use**, **Allow maturity levels**, **Qualify to be an evolved way of managing Information in Building**, **Makes BIM global - beyond industry**, **Involve both humans and machines**, **Involve both business and life**, **Provides core understanding**, **Simple, but not simpler than possible**, **Sub-context independency**, **Providing sufficient extensional clarifications**, **Divide the clarifications or extensions in taxonomic alignment**.

The limiting conditions or the fallacies are: **Marginalised as Representation**, **Information-centric in a way ignores Modelling**, **Missing the terminology of Modelling**, **Limited to Physical and/or Functional Characteristics**, **Repository or Source of Truth as this condition belongs to CDE**, **Narrowed to facility or project**, **Marginalised as Parametric Modelling**, **Create or Generate or Develop or Use instead of the word Modelling**, **Shared and Interoperability without addressing Semantic Integrity**, **Compelling condition of being three-dimensional**, **Software or Electronic Model without being specific**, **Data model or Modelling in a way that ignores the evolution of Information Modelling**, **Compelling condition of being real-time**, **Referring assets only with regards to physical existence**, **Building - as a noun**, **Attempt to define the application areas that are indefinite and**

monitor, extract, exchange, or execute the data and models using the semantics or the continuity of Modelling in connection to several use cases.

Extensional Definition (a precisng definition): *Where, Building is a terminology for the end to end lifecycle phenomenon of things that are spatial compositions and actions (products and processes) that contribute, produce, use and maintain, restore or recycle, and record sustainable and healthy built environments with respect to the knowledge, policies, tools, resources, lives and natural environments they exist referring land, water, and air.*

Extensional Definition: *Where, the Datafied life and business refer to the semantic integration of data from various sources to inform and interact with the machines, business systems, living environments and even the cognition of lives - generating (or Modelling) the responses to their circumstances in a robust and intelligent manner. While Information refers to human comprehension, Datafication is referring to the integration reaching as far as the cognition of techno-social entities. Techno-social entities refer to both the machines that recognise the responses of lives and the lives that integrate their cognition to the responses of machines.*

5. CONCLUSION

This research testifies that the term BIM is highly relevant to a sound theory as this new definition implies. The term BIM is fully qualified to carry the weight of this complex phenomenon for now and in future. One of the fallacies or dilemma over the two decades could be the isolation of the I or the *Information* from the term *Information Modelling*; thus, the connection to its taxonomy parent was poorly conceptualised. Other part of the term BIM is *Building*, which has not been realised before as an “*end to end lifecycle phenomenon of things and actions*” - this research is privileged to serve this understanding. The noble purpose of BIM - making aid for humans to build sustainably has been well emphasised in this new definition. The given direction for BIM helps the practice, policies, and research to align towards the future evolution as a principle. This is not simply another *Ostensive Definition* for BIM, but the only *Intensional Definition* given for BIM to date following the ISO requirements for terminology works and definitions. However, the research has achieved the pursuit on fundamentals more than the resulted definition. The persuasion of fundamentals has reached to a level of defining BIM intensively for the first time since the introduction of the terminology BIM two decades ago.

The important terminologies that are contributing to the *Intensional Definition* are clarified as *Extensional Definitions*. The definition for BIM developed in this research is potentially a breakthrough and stipulates a rich theory and a profound taxonomy. Therefore, this definition can be accepted globally for now while being aware that it might evolve. Moreover, this research suggests to further break-down this *Intensional Definition* into parts and build maturity levels or stages for each condition and then aggregate as implementation and maturity levels such as UK-BIM level-2 or the Stages in ISO 19650 or the generic frameworks such as UK BIM Framework. A stipulative definition for BIM with a clear objective, direction, and expressive completeness while meeting the necessary and sufficient conditions without circularity is truly a breakthrough. The quantitative score of this new definition guarantees its reliability. This research calls the initiatives to use the term BIM confidently along with this proven definition and theory rather than using its taxonomy relatives as terminological alternatives. The aim of this research to re-establish the truth of BIM from its fundamentals rather than re-inventing the wheel once again has been achieved well as awaited by a number of theorists and practitioners and initiatives globally.

6. REFERENCES

- Abanda, F. H., Keivani, R., & Tah, J. H. M. (2013). Trends in built environment semantic Web applications: Where are we today? *Expert Systems with Applications*, 40(14), 5563-5577.
- AGC. (2005). *The Contractors Guide to BIM*.
- AIA. (2007). *Integrated Project Delivery: A Guide* [1].
- AIA. (2013). E203 - Building Information modelling and Digital Data Exhibit. In: American Institute of Architects.
- Allen, B. (2017). The Future of BIM Will Not Be BIM and It's Coming Faster Than You Think. *Autodesk University*.
- Anderson, R. (2010). An Introduction to the IPD Workflow for Vectorworks BIM Users In (1 ed.). Columbia: Nemetschek North America, Inc.

- Autodesk. (2002). Autodesk Building Industry Solutions: Building Information Modeling. In *White Paper: Autodesk*.
- Barron, C., & Laiserin, J. (2003). Laiserin letter: Graphisoft on BIM. In: Laiserin letter.
- Bentley, K., Workman, B., & Laiserin, J. (2003). Bentley Systems on BIM. In: The Laiserin Letter.
- BSI. (2010). BS8536:2010 Facility management briefing. Code of practice. Retrieved from <https://shop.bsigroup.com/ProductDetail/?pid=00000000030212807>
- CANBIM. (2014). BIM Protocol: Implementing Canadian BIM Standards for the Architectural, Engineering and Construction industry based on international collaboration. In (1 ed.): AEC(CAN).
- CIC. (2013). The Outline Scope of Services for the Role of Information Management. In. London: CIC UK.
- Cook, R. T. (2009). *A Dictionary of Philosophical Logic*. UK: Edinburgh University Press.
- CRC. (2009). *Cooperative Research Centre for Construction Innovation: National Guidelines for Digital Modelling*. Brisbane, Australia.: Icon.Net Pty Ltd.
- Crumley, J. S. (2006). *A Brief Introduction to the Philosophy of Mind*: Rowman & Littlefield Publishers, Inc.
- Davis, D. (2007). Presentation on National Building Information Model Standard NBIMS. In: AEC Infosystems.
- Downes, S. (1996). Stephen's Guide to the Logical Fallacies. In.
- Eastman, C. (1973). An Interrogation Language for Building Description Systems. *Institute of Physical Planning Technical Report*.
- Eastman, C., & Henrion, M. (1977). GLIDE: A Language for Design Information Systems. *ACM SIGGRAPH Computer Graphics*.
- Eastman, C., Teicholz, P., Sacks, R., & Liston, K. (2008). *BIM Handbook: A Guide to BIM for Owners, Managers, Designers, Engineers, and Contractors*: John Wiley & Sons, Inc.
- Eastman, C., Teicholz, P., Sacks, R., & Liston, K. (2011). *BIM Handbook: A Guide to BIM for Owners, Managers, Designers, Engineers, and Contractors* (2 ed.). New Jersey: John Wiley & Sons, Inc.
- Eastman, C. M. (1981). *Recent developments in representation in the science of design*. Paper presented at the Proceedings - Design Automation Conference.
- El-Diraby, T. E. (2012). Epistemology of Construction Informatics. *Journal of Construction Engineering and Management*, 138(1), 53-65.
- Fuchs, S., & Scherer, R. J. (2017). Multimodels — Instant nD-modeling using original data. *Automation in Construction*, 75, 22-32.
- Galle, P. (1995). Towards integrated, “intelligent”, and compliant computer modelling of buildings. *Automation in Construction*, 4, 189-211.
- Green, E. (2016). BIM 101: What is BIM? Retrieved from www.engineering.com/BIM/ArticleID/11436
- GSA. (2007). GSA Building Information Modeling Guide Series 01 – Overview. In. Washington, DC.: U.S. General Services Administration.
- Harnad, S. (1990). The Symbol Grounding Problem. *Physica D: Nonlinear Phenomena*, 42(1-3), 335-346.
- Hurford, J. R., & Heasley, B. (1983). *Semantics: A Coursebook* (1 ed.): Cambridge University Press, UK.
- Irmeler, R., Franz, S., & Ruppel, U. (2018). *IoT - An Opportunity for Autonomous BIM Reconstruction*. Paper presented at the 25th EG-ICE Conference: Advanced Computing Strategies for Engineering, Switzerland.
- ISO 19650-1. (2018). Organization and digitization of information about buildings and civil engineering works, including BIM - Information management using BIM Part 1: Concepts and principles. In (Vol. 1).

- ISO 29481-1. (2016). ISO 29481-1 Building information models - Information delivery manual - Part 1: Methodology and format. In: International Organization for Standardization.
- Jackson, R. (2013). BIM Blog: Speaking a Common Language. Retrieved from <https://bimblog.bondbryan.co.uk/speaking-a-common-language/#more-437>
- Jackson, R., McKinnell, S., Platts, T., Redmond, K., Reed, D., & Woddy, P. (2016). Bond Bryan Digital: BIM Dictionary. In (P09 ed.): Bond Bryan Architects Ltd.
- Jernigan, F. E. (2007). *Big BIM, Little Bim: The Practical Approach to Building Information Modeling : Integrated Practice Done the Right Way!* (illustrated edition ed.): 4Site Press.
- Jurčević, M. (2017, 2016-09-05). Definition of BIM Technology. Retrieved from <https://www.engipedia.com/definition-bim-technology/>
- Kubba, S. (2017). *Handbook of Green Building Design and Construction - LEED, BREEAM, and Green Globes* (2 ed.): Elsevier Inc.
- Laiserin, J. (2002). Laiserin letter: Comparing Pommés and Naranjas. Retrieved from <http://www.laiserin.com/features/issue15/feature01.php>
- McPartland, R. (2017). The BIM 'label' : Is the term still fit for purpose? Retrieved from <https://www.thenbs.com/knowledge/the-bim-label-is-the-term-still-fit-for-purpose>
- Mordue, S. (2016). Opportunities and threats: Definition of BIM. In: Architects' Council of Europe.
- NBS. (2011). *NBS: Building Information Modelling Report March 2011*. Retrieved from
- NHBA. (2011). Norwegian Home Builders' BIM Manual. In (1 ed.). Oslo: Norwegian Home Builders' Association.
- NIBS. (2007). National BIM Standard. In: National Institute of Building Sciences (USA).
- NIBS. (2015). National BIM Standard – US® Version 3. In (3 ed.): National Institute of Building Sciences.
- Poljanšek, M. (2017). *JRC Technical Reports: Building Information Modelling standardization*. Retrieved from
- Ravenscroft, T. (2016). BIM Terminology: The long and short of BIM terminology. Retrieved from <http://www.bimplus.co.uk/explainers/long-and-short-bim-terminology/>
- Reddy, K. P. (2011). *BIM for Building Owners and Developers: Making a Business Case for Using BIM on Projects*: John Wiley & Sons, Inc.,.
- RIBA. (2012). *BIM Overlay to the RIBA Outline Plan of Work*.
- Snook, K. (2016). BIM - it's about the Planet - Parts 1 to 5. Retrieved from https://www.designingbuildings.co.uk/wiki/BIM_-_it%27s_about_the_Planet_-_Part_1
- Snook, K. (Online). Drawing Is Dead – Long Live Modelling. Retrieved from <http://www.cpic.org.uk/publications/drawing-is-dead/>
- UKBIMA. (Online). Constructing Language Pledge. Retrieved from www.ukbimalliance.org/project/constructing-language-pledge/
- VA. (2010). The VA BIM Guide. In (1 ed.): The United States Department of Veterans Affairs (VA).
- VA. (2016). VA BIM Manual V2.0. In: U.S. Department of Veterans Affairs.
- Vogt, B. (2010). Relating BIM and architectural engineering curricula. In: Kansas State University.
- Winfield, M. (2015). Building Information Modelling: The legal frontier overcoming legal and contractual obstacles. In: The Society of Construction Law.

EMPLOYING BIM-BASED GEOSTATISTICAL ANALYSIS TO DESIGN A MONITORING ARRANGEMENT

Mahmoudi E & Yilmaz F & König M

Department of Civil and Environmental Engineering, Ruhr-Universität Bochum, Germany

ABSTRACT: *In infrastructure projects like tunnel construction, an accurate determination of the surrounding geomaterials has considerable influence. In this regard, digital soil models are created based on the existing geological exploration data and the entire formation of the surrounding environment is interpolated. However, the limited number of investigated boreholes and the natural randomness in the subsoil, lead to a high level of uncertainties, which may affect the decision-making process, severely. To address this issue, the present study developed a concept with geostatistical interpolation methods that recognizes the interaction between the exploratory data and qualify the uncertainties of the obtained digital soil model. Also, to be able to carry out comprehensive planning, the geological properties are mapped in a BIM model for further usages. A soil model consisting of voxels is developed via Revit-Dynamo to represent uncertainties between boreholes. In this study, with the help of Kriging interpolation, the quantification and visualisation of uncertainties are performed. Based on the representing model in Revit-Dynamo, analytical statements can be made about the soil type between the boreholes, along with the reliability of such prediction. Moreover, by appropriate developments with additional criteria, the proposed concept can identify the risky locations in the geological models for further geological investigations and reveal an optimised experimental design.*

KEYWORDS: *Geostatistics, Tunnelling, BIM concept, Optimal experimental design*

1. INTRODUCTION

In recent decades, mechanised tunnelling in urban areas has gained increasing importance. For example, from a study carried out in Germany, the share of shield tunnelling in Germany increased from 13% to 60%, between 2000 and 2013 (Haak, 2013). An accurate numerical simulation of a mechanised tunnelling process in urban areas must consider the complex interactions between subsoil and the tunnel boring machine. Besides, due to the natural origin of the geomaterials, their characteristics deal with randomness (Mahmoudi et al. 2017). The associated uncertainty inherent in geomaterials, and/or uncertainty in the interpretation or assumption of the ground formation may lead to notable deviations in the prediction of soil-structure interactional behaviour. As an example, underestimating the tunnel-induced settlement because of wrong parameter identification may force severe damage to ground structures. Note that the uncertainty of the model is not always spatially uniform, depending on the complexity of the geological formation (Mahmoudi et al. 2020). Moreover, it has to be kept in mind that the accuracy of the obtained parameter is closely related to the chosen observational campaign, such as the number of driven boreholes, as well as their location. A well-considered position of boreholes can increase the quality of the measurement and reduce the involved uncertainties in the design phase (Hölter et al. 2019). Therefore, to minimise the uncertainties effect in the behaviour of mechanised tunnelling, the designer should be given a clear picture of the subsoil. Such a picture includes the geometrical data of different geological layers, which may be encountered during the excavation, and their related hydro-mechanical properties. The first step in the design of a mechanised tunnelling project is to choose the proper alignment, which strictly depends on the knowledge of the subsoil formation to propose an alignment for preventing accidents like face collapse, ground subsidence, water inflow or severe squeeze. The representation of the complex soil conditions can be done with the help of digital soil models to deliver a clear geological understanding. In addition, the subsoil around the underground structure can be observed digitally over its entire life cycle. Such a 3D representation together with geotechnical expertise can adjust the time-critical decisions for the further construction phases. It leads to corresponding time and cost savings.

The digitally generated models visualize the soil conditions using data from the performed geotechnical site investigations that are taken place in sparse locations. Soil investigation includes geological survey data, drilling data, geophysical exploration data, and various in-situ and laboratory tests performed on given samples, but only at specific locations in order to analyse the soil behaviour. In practice, the modelling of the subsoil is performed with existing platforms that mainly use linear interpolation methods to predict the untested areas' properties with the given information. Such visualisation does not consider any spatial uncertainty between the monitored locations. This results in uncertainties in the created soil model. Also due to the inhomogeneity of the subsoil, the uncertainty of the created model is unknown. Therefore, planning on the basis of the subsoil model can be subjected to errors. It may lead to high additional costs, structural damage and even to the endangerment of human life.

Moreover, in major projects as tunnelling, the performance of the simulation models may depend on different

aspects and disciplines like geology, permeability, geochemistry, geophysical properties, crack distribution and mechanical properties. Such information has to be transported in a data format to be developed together and be consistent with other design models for further time and cost analysis. This model needs to be consistent with geotechnical units described in geotechnical design reports, including the associated geotechnical design parameters. Smoothing data transfer between different involved sections is the main concern of the building information model (BIM) concept. To model geological information and topography of geotechnical layers, a model called GeoBIM that extends the BIM concept was proposed by Zobel (2008). GeoBIM provides a subsurface information model, which separates natural subsurface objects such as soil layers from engineering subsurface objects like pipes or tunnels. However, the proposed model was not designed to handle involved uncertainties.

In the investigations of El Gonnouni et al. (2005) the influence of uncertainties in connection with the soil variability caused by civil engineering works was analysed. Furthermore, a stochastic finite element method was applied to introduce the influence of uncertainty on the predicted surface settlements. Based on numerous in-situ experiments a geostatistical method was applied to determine the mean position of the soil layers and their estimation deviations. The optimal variogram model was performed with a sensitivity analysis. The best compromise was found by changing the specific values, such as the range.

Within the framework of the investigations of Sotiropoulos et al. (2016), the spatial modelling software SURPAC was used to analyse the geotechnical conditions and to identify the problems that occurred during the construction of the underground hazardous waste disposal site of the Lavrion Technology and Culture Park. The results of the analysis showed a good agreement with the real conditions. The high-risk areas with reduced geotechnical characteristics were identified and the resistance of the rock pillars was assessed. The spatial interpolation was carried out with the inverse distance weighting (IDW) method.

Given the inherent heterogeneity of natural soils, the use of laboratory data allows only a very rough estimation. Hence, it is recommended to use the optimal experimental design (OED) approach in the context of which in-situ measurements should be used to develop an existing model of construction or to validate them. The purpose of OED is to increase the effectiveness of measurements concerning the quality of the forecasts derived from them. Hölter et al. (2018) utilised OED in mechanised tunnelling process, where time and location both play a role as depending on the current position of the TBM different possible measurement positions become relevant. After evaluating sensitivity distributions of different areas of the model domain at different time steps, it suggested a custom-tailored measurement design.

The present work deals with the question of how the uncertainties in digital soil modelling can be quantified. A concept for the quantification and visualisation of the uncertainties in the soil model is proposed. The objective of this study is to be achieved by employing stochastic approaches. In the present study, a concept for quantifying the accuracy of the digitally created soil model is developed in the framework of the BIM concept. Based on the performed accuracy quantifications, additional exploration work can be carried out at necessary locations. By an optimal spatial arrangement of the core drillings, cost-intensive site investigations can be avoided and at the same time, a risk minimization can be achieved. The paper follows by explaining the employed techniques in section 2. The last section of the current research presents some of the outcomes of the proposed concept. In addition, section 3 involves the idea of OED to utilise the introduced 3D interpolation visualisation concept in the selection of optimum borehole locations. The paper is concluded in section 4.

2. METHODOLOGY

2.1 Spatial interpolation methods

The interpolation methods assign a continuous function to given discrete data and enable its representation by the exact fitting. Various interpolation methods are developed to estimate the unknown spatial variables on the basis of the known measured data. The spatial interpolation can be carried out in different approaches. A distinction is made between deterministic and stochastic approaches. Deterministic methods calculate the weights based on similarity and are based on a single discrete value for the parameter under consideration. Stochastic approaches consider the spatial autocorrelation of points to determine the weights. The spatial relationship of the data is represented by the autocorrelation structure of measurement spots. Different types of kriging methods belong to this category of interpolation techniques. Compared to geostatistical methods, deterministic methods do not take into account the spatial correlations of the observed data. The weights are mainly calculated on the basis of similarity or the degree of smoothing. Deterministic methods include interpolation techniques such as splines, IDW, local and global polynomial interpolation, Dirichlet/Thiessen/Voronoi polygon, Delaunay triangulation or Radial Base Functions (Wackernagel, 2003).

2.2 Kriging

Many interpolation methods were developed to represent the sample data in the unsampled area. Kriging family of methods can be mentioned as one of those commonly used. The French mathematician Georges Matheron developed the theory of kriging and named it after the South African engineer Danie G. Krige, who proposed the first developments in geostatistics in the gold mines (Matheron, 1962). Although the Kriging method was developed for mining, it is used in many areas such as soil science, forestry, agriculture and ecology.

Kriging methods rely on the notion of autocorrelation. Correlation is usually thought of as the tendency for two types of variables to be related.

In definition, kriging is a regression method for estimating point values (or spatial averages) at any location of a region. This linear predictor is a weighted average of the observations, with an objectively optimal method of assigning the weights. The basic principle of kriging is to weight the closer areas more than the further ones. Kriging, like other geostatistical methods, assume that all values in the field result from a random process, but they are not independent. To uncover the principles of this dependency, kriging utilises the concept of covariance function estimation, or so-called, variograms. The main strength of kriging as a geostatistical method is the statistical accuracy of their predictions that provides the estimation based on the known values alongside with the probable statistical error. The most common kriging methods regarding the use of the autocorrelation structure are simple kriging, universal kriging or ordinary kriging. In ordinary kriging, however, no trend is implemented, and the data are assigned a constant mean value.

In this study, the interpolation concept is developed under the assumptions of ordinary kriging. In ordinary kriging, a linear combination of weights at known points is used to estimate the value at an unknown point, assuming the existence of second-order stationarity. Each individual point estimate $\hat{Z}(x_0)$ is considered a linear combination of the values of the regionalized variables at n points where the values $Z(x_i)$ are known. The weighting of the individual values is achieved by introducing n different λ_i -weights. The following equation, therefore, applies to the estimated value,

$$\hat{Z}(x_0) = \sum_i \lambda_i Z(x_i), \quad \text{where } \sum_i \lambda_i = 1.$$

This allows an infinite number of i solutions. The best estimate is that which reduces the variance of the estimation errors.

$$\text{Var}\{\varepsilon(x)\} = \text{Var}\left\{\sum_i \lambda_i Z(x_i) - Z(x_0)\right\}$$

In the matrix notation, the entire system of equations used to determine the weightings can be represented as follows

$$\mathbf{A}\boldsymbol{\lambda} = \mathbf{b}$$

Where, the column vector \mathbf{b} contains the estimated variances of the estimated value and known values. To solve the system of equations, the column vector \mathbf{b} must be introduced. By forming the inverse of the matrix \mathbf{A} and multiplying it by the column vector \mathbf{b} , the desired weights are obtained. Matrix \mathbf{A} contains the variance values of the point pairs $\gamma(x_j, x_j)$ determined from the model variogram. Variograms are the basic tool for the structural interpretation of phenomena and estimation. The variogram determines the influence of the measuring point on the random variable. As an example, the Gaussian-based variogram

$$\gamma(h) = C \left[1 - e^{-\left(\frac{3h}{a}\right)^2} \right]$$

Where C is the Sill value, here is assumed to be equal to 100%, a is the range and the h is the lag distance between x_j and x_j .

2.3 Uncertainty quantification

The uncertainties are modelled as random variables. To determine the uncertainty, a three-phase procedure is implemented. In the first phase, the realization of the involved uncertainties using the concept of semi-variogram takes place. Here, all the identified separate layers in each borehole are considered to affect the interpolation accuracy of each place in the soil formation. In practical projects, where the entire domain of analysis is more extended, a search domain should be defined. The first suggestion for such a domain is to set the search radius not bigger than one-third of the longest distance in the domain. In the second phase, the correlation matrices are set

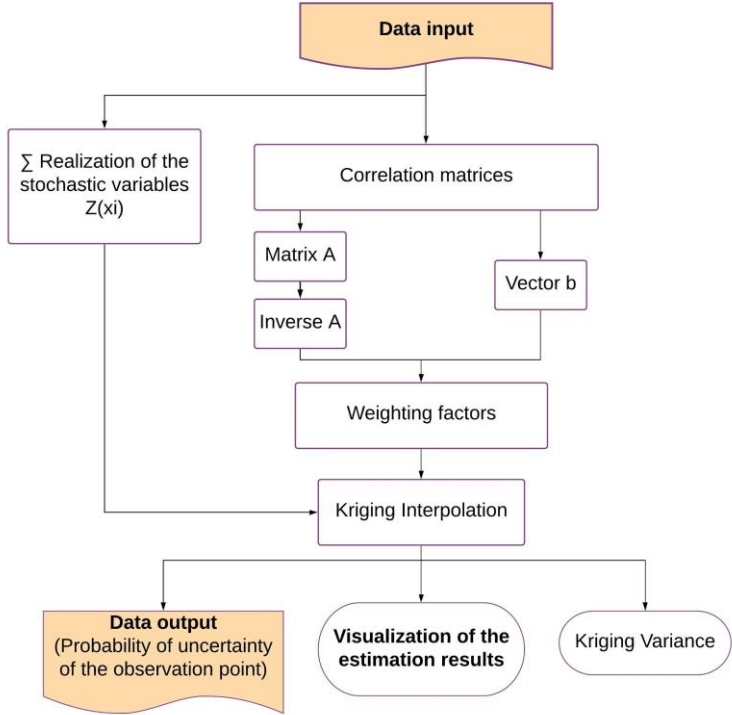


Fig. 1: The applied workflow

up and then the weighting factors are determined. The determined weights are multiplied by the random variables (uncertainties) so that a mean value (final uncertainty) of the searched point is geostatistically estimated. In this concept, the estimation point, as well as the estimation errors (kriging variance), are specified. Fig.1 illustrates the implemented workflow.

2.4 BIM-based modelling

The developed concept and the explained phases are implemented in Revit-Dynamo and a synthetic soil model is created. Dynamo is a graphical algorithm editor to extend building information modelling workflow. The implementation is executed with various blocks. The relations between the blocks are established with wires, that the data pulses are transported with them (see Fig. 2 that illustrates the script, partially). In the first step, the created tables in .xlsx or .csv format must be imported. These data formats are common in civil engineering practice and enable the designers to deal with the same data format in different platforms. The imported information includes the location of each borehole and the identified geological layers, to be used for further processing. In the next block, the layers and layer boundaries of the boreholes are displayed. Each type of soil present in the borehole is visualised with the start and endpoints of the layer. By connecting these points cylindrical bodies are created. By connecting the boreholes with a polygon, an upper and lower limit for the soil model is created. When multiple

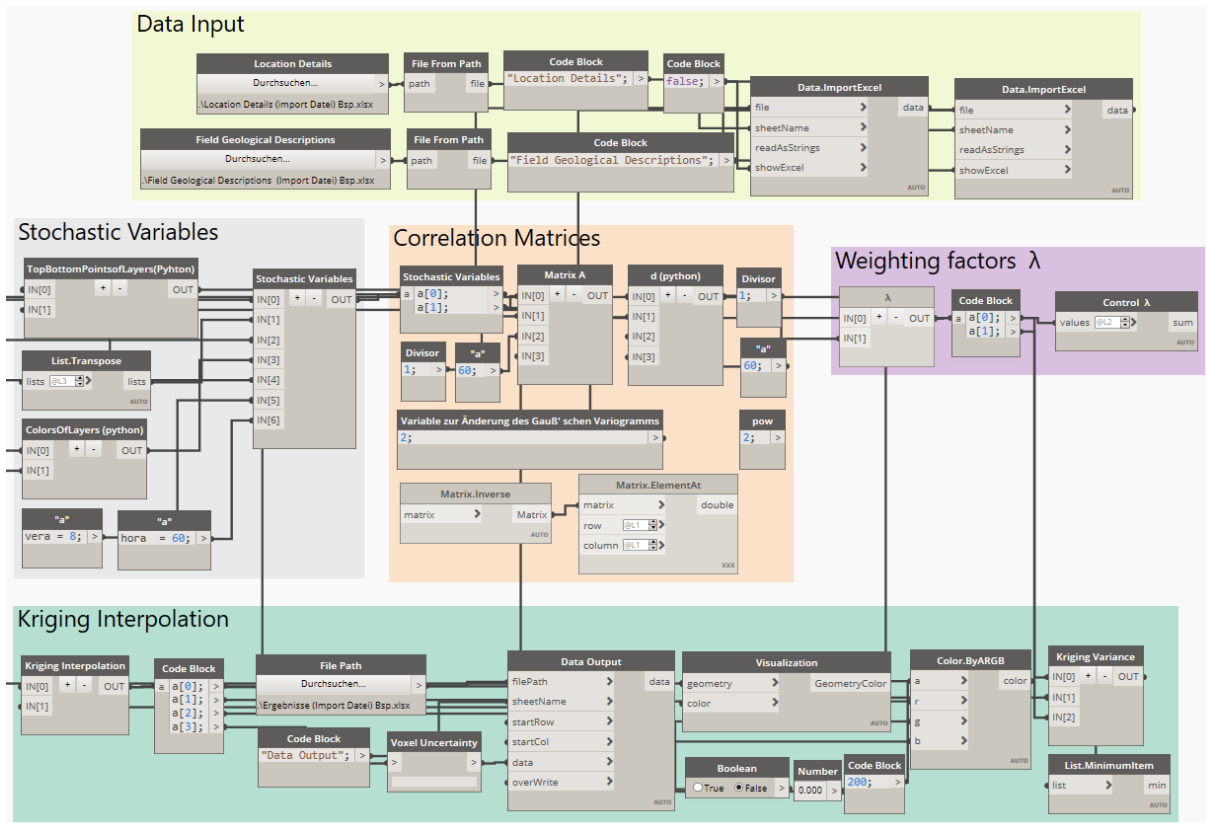


Fig. 2: Dynamo script

holes are added, the polygon can expand. This feature enables us to investigate later the optimum observational design.

In following, a solid body is created between the two entered polygons. Within the resulting topography (mesh) the kriging interpolation is performed. Before the entire voxel model can be created, a point cloud must first be created. The points contained in this point cloud are later displayed as representative voxels. The size of representative voxels can be adjusted in this step based on the defined goals for OED studies. When placing sensors are expected, the smaller size of voxels delivers more accuracy about the favourable location, while localisation of digging boreholes can be performed with less accuracy.

The statistical calculation is carried out based on the location of the voxel centre point. Depending on the situation, the corresponding variogram (vertical or horizontal) is calculated. Each voxel is investigated based on the observed layers in all the surrounding boreholes. In this step, the parameter a (range) and type of semivariogram model can be adjusted. Afterwards, the correlation matrices for determining the weighting factors are created and the kriging interpolation is performed, accordingly. To do this, the kriging matrices explained in section 2.2 are created. Here, by applying Python blocks, the larger block groups are replaced with lines of codes.

As a final step, the results of the data flow were visualized in a three-dimensional preview. An example of implementation output is shown in Fig. 3. The figure represents a soil body consist of voxels, where the data of three borehole logs were available. Borehole logs depicted two soil layers with different depth. The represented accuracy colour legend applies for all further presented results.

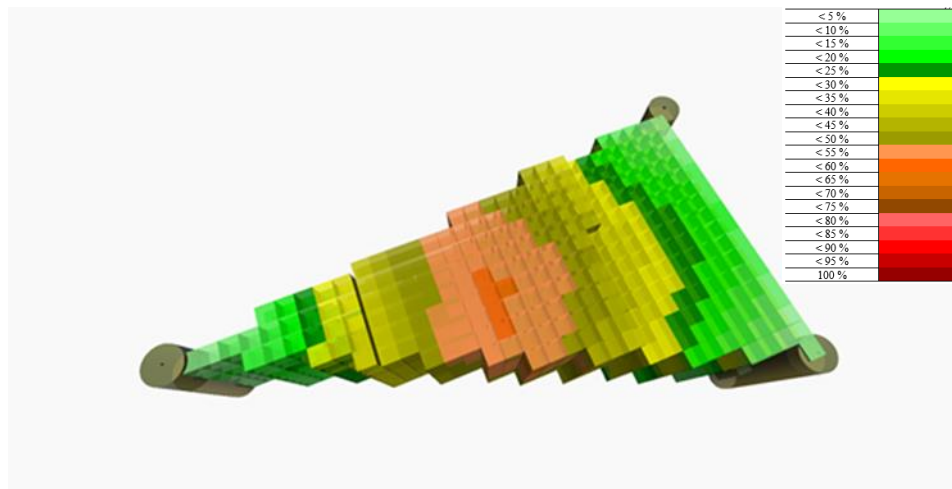


Fig. 3 Exemplar uncertainty distribution in soil body

3. Results

The range is the distance after which the semivariogram levels off. It means that after this certain distance, there is no correlation between the spatial attributes. Therefore, the interpolating process of unknown points in further distance involves the highest uncertainty level. In practice, this parameter should be determined via the calculation of empirical semivariogram (Webster and Oliver, 2007). The developed implementation enables the user to adjust this parameter in addition to the considered variogram model. Here it should be mentioned that the range value can be anisotropic in the soil body due to its formation history. In sedimentary soil types, the correlation length in the horizontal direction is generally bigger than the vertical one. In the present study, the existing anisotropy is implemented by considering different range value, while both horizontal and vertical direction follows the same correlation model. Table 1 represents the results of investigating the effect of range value. Here the semivariogram follows a Gaussian model and the vertical range is kept the same. The obtained results show the great effect of horizontal range in the investigation. The next study is performed on the effectiveness of model variogram's selection. Table 2 represents the outcomes of assigning different models. The results are in favour of using the exponential model variogram in this specific case study. However, the type of model variogram should be selected based on the shape of the empirical variogram.

The next step in the investigation belongs to find out the optimum location for digging new boreholes. In any case that the presented concept determines areas with a high amount of uncertainties in interpolation, the designer must require new measurements to ascertain the interpolation procedure. Localization of new observational spots can be investigated via the proposed concept, as well. In this regard, the designer may try various combination of potential borehole plans and compare the uncertainty measures of each plan. Fig.4 depicts the outcomes of such an investigation. In the original case study (i.e., Fig. 4a), there were four boreholes and the calculation results show the highest uncertainty level (around 40%) where a black circle is illustrated. Three new locations for digging a new borehole are studied. In the following, the related uncertainty measure on that certain voxel is calculated. The results are represented in a diagram format (Fig. 4e). Adding a new borehole in the closest location decreased the uncertainty level, drastically. Meanwhile, digging a new borehole in distance (Fig. 4d) even increased the uncertainty level. Here, the importance of defining a certain neighbourhood for interpolation is determined. The main goal here is to illustrate the ability of the implemented model to be expanded and employ the new measurements.

Table 1: Effect of change in range (the studied voxel circled in black)

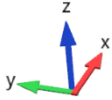
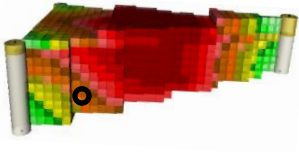

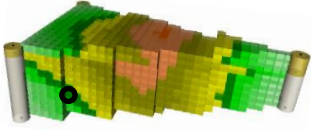
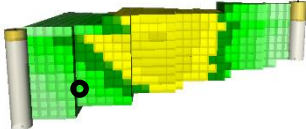
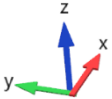
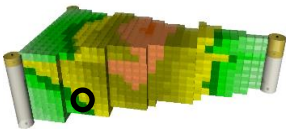
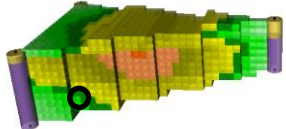
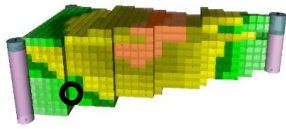
Range	Uncertainty	Illustration 
25 m	100 %	
40 m	80.30 %	
60 m	50.68 %	
80 m	32.73 %	

Table 2: Effect of change in applied semivariogram model (the studied voxel circled in black)

Applied variogram model	Uncertainty measure		Illustration 
Gaussian	U	50.684 %	
	s^2	0.4777	
Exponential	U	39.502 %	
	s^2	0.6469	
Spherical	U	53.099 %	
	s^2	1.421	

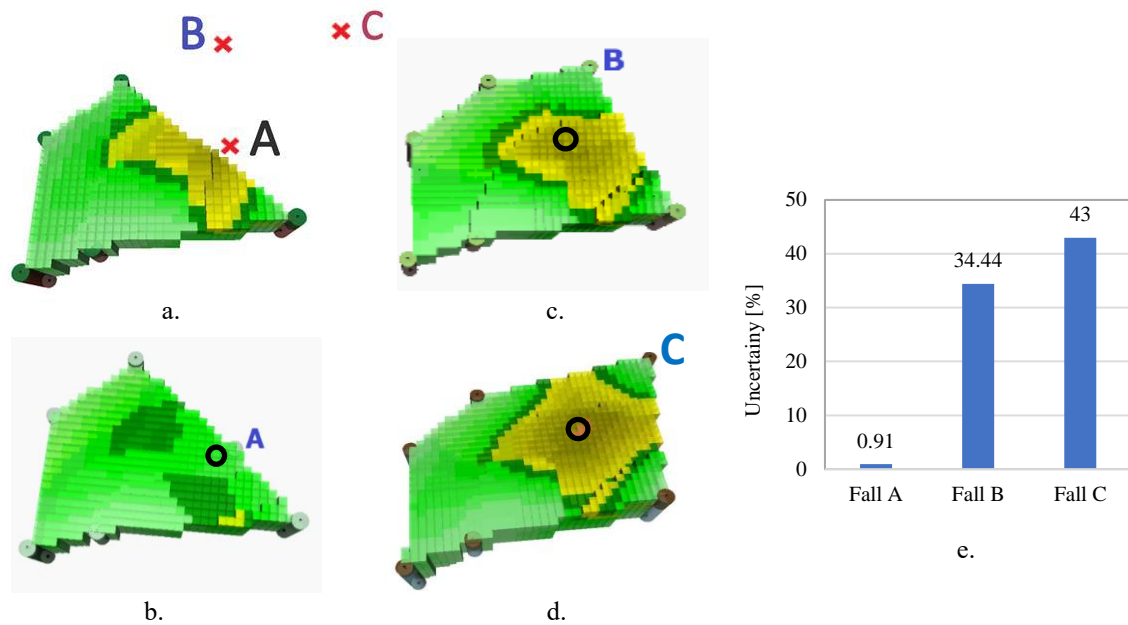


Fig. 4: Analysis of optimal location to drill new borehole and regarding uncertainty measures

4. Conclusion and remarks

In infrastructure projects like tunnel construction, the properties of the subsoil are of great importance. Digitally generated subsoil models enable the visualization of the subsoil properties based on the geotechnical surveys and are available for further analyses of the soil conditions and decision phases.

A quantitative determination of the uncertain areas of the soil model does not exist in the current software platforms. In the context of the present research, an attempt is made to answer the question of how the uncertainties in digital soil modelling can be quantified and updated. For this purpose, a BIM-based geostatistical interpolation concept is developed which quantifies and visualizes the uncertainties using scattered data and at the same time provides the prediction error. The investigations, which are carried out using a synthetic soil model, showed that the developed methodology fulfilled the requirements of the kriging method. The effects of variogram parameters, such as the range and the covariance function, were investigated based on some parameter studies and it is concluded that the change of these parameters has a significant influence on the model. Moreover, a synthetic model is used to test the OED concept. Through the implementation, alternative locations for new boreholes are generated and their uncertainties are quantified.

For further research to identify the risky spots in the geological models, the development of this approach with additional criteria regarding the search neighbourhood and consideration of barriers and trends in real cases (by employing different interpolation methodologies) should be considered. Also, the optimization process to localise new boreholes can be expanded via different existing OED methods.

5. REFERENCES

- El Gonnouni M. and Riou Y. and Hicher P. Y. (2005). Geostatistical method for analysing soil displacement from underground urban construction. *Geotechnique* Vol. 55, No. 2, 171-182.
- Haack. A. (2013). Tunnelbau in deutschland: Statistik (2012/2013), analyse und ausblick. *Tunnel*, Vol. 8, 24-37.
- Hölter R. and Zhao C. and Mahmoudi E. and Lavasan A. A. and Datcheva M. and König M. and Schanz T. (2018). Optimal measurement design for parameter identification in mechanized tunneling. *Underground Space*, Vol. 3, 34-44.
- Hölter R. and Mahmoudi E. and Rose S. and König M. and Datcheva M. and Schanz T. (2019). Employment of the bootstrap method for optimal sensor location considering uncertainties in a coupled hydro-mechanical application. *Applied Soft Computing*, Vol. 75, 298-309.

- Mahmoudi E. and Khaledi K. and Miro S. and König D. and Schanz T. (2017). Probabilistic analysis of a rock salt cavern with application to energy storage systems. *Rock Mechanics and Rock Engineering*, Vol. 50, No. 1, 139-157.
- Mahmoudi E. and Schmüdderich C. and Hölter R. and Zhao C. and Wichtmann T. and König M. (2020). Stochastic field simulation of slope stability problems: improvement and reduction of computational effort. *Computer Methods in Applied Mechanics and Engineering*, Vol. 369, 113167.
- Matheron G. (1962). *Traité de géostatistique appliquée*, Tome1, Technip, Paris.
- Mitas, L. & Mitasova, H. (1999). Spatial interpolation. *Geographical information systems: principles, techniques, management and applications*. Vol. 1, No. 2, 481-492.
- Sotiropoulos N. and Benardos A. Mavrikos A. (2016). Spatial modelling for the assessment of geotechnical parameters. *Procedia Engineering*, Vol. 165, 334-342.
- Wackernagel, H. (2003). *Multivariate Geostatistics*. Springer Verlag, 3rd Edition.
- Webster R. and Oliver M. A. (2007). *Geostatistics for environmental scientists*, John Wiley & Sons, 2007.
- Zobel F. and Marschallinger R. (2008). Subsurface geo building information modeling geobim. *GEOinformatics*, Vol. 8, No.11, 40-43.

ILLUMINATING THE IDEOLOGICAL DEVELOPMENTS OF BIM TO APPRAISE THE TERMINOLOGY BIM

Githyon Prabhu & Henry Abanda

Oxford Brookes University, United Kingdom.

ABSTRACT: *The critical fitness of the terminology Building Information Modelling to what it applies has been poorly conceptualised even though BIM is a paradigm shift over two decades. Digitisation initiatives and the subsequent literature do suffer taxonomy misalignments of terminologies and missing theoretical basis. Introducing buzzwords persuading a few contextually defining conditions are attempts but never-ending. This research aims to establish the critical fitness of the terminology BIM by explicating the ideological development of this terminology and definitions to facilitate the context-independent view of the complicated truth without reinventing BIM once again. In pursuit of fundamentals, a qualitative method is employed with the inductive approach. The study contributes towards a context-independent definition of BIM that carefully stipulates all the necessary characteristics that can be used in any circumstances anywhere.*

KEYWORDS: *BIM, History of BIM, Ideology of BIM, Evolution of BIM, Taxonomy of BIM, Terminology in BIM.*

1. INTRODUCTION AND RATIONALE

The phrasal or the term *Building Information Modelling* or its acronym *BIM* stands for one of the most successful applications of *Computer Science* in the building industry. A prodigious number of documents have been produced during the last two decades. However, most of them are focused on the word *Information* while treating the word 'modelling' as secondary by understanding that the 'models' are nothing but parametric miniatures in computers. Some documents have replaced or recommended to replace the word 'modelling' with management or methodology. In other cases, the word *Building* has been replaced with other words such as bridge, marine, asset, facility, or project. Altogether, some documents on BIM have used rather alternative terms and avoided or marginalized the term BIM from being used predominantly. There are several terminologies and definitions for BIM; however, even the pioneers and experts have perceptually concluded that this label BIM and the given definitions are not adequate in communicating the relevance to the extent of the practice and the potential. Therefore, the critical fitness of the terminology BIM is researched in this study to establish a wider understanding. In an attempt to resolve the dilemma, the literature is reviewed critically from the history of BIM to its futuristic views. The terminological evolution of BIM and its definitions are studied in order to identify the taxonomy, ontology, fundamental principles, and the general understanding of both *Computer Science* and *Building Science*.

The dilemma is explicit about the term *Building Information Modelling*, the acronym BIM, relating to its practice, and communicating the meanings. It is concluded by many that BIM is far from self-explanatory, and it leaves people with a number of questions, and unfortunately, each question has multiple answers (Green, 2016). Secondly, the acronym BIM has many alternative phrasal terms such as *Building Information Model*, *Building Intelligent Model*, *Building Information Management*, *Building Information Methodology*, *Better Information Management* and many more. These issues prove that the world is not in full agreement about BIM while it is true that there are ISO documents for BIM. Thirdly, the term *Building Information Modelling* or BIM has been noted by many as an inaccurate label for the functions being undertaken by the industry using this label. For example, McPartland (2017) conveys an industry view that the label BIM doesn't carry or communicate the depth and breadth of what is being driven by people, processes and the technology. Finally, BIM had many hypes (Day, 2010), resultantly the awareness of BIM is near-universal in a way that we cannot rename or reverse it (McPartland, 2017). The technology is not found in literature as the industry works and understands in many cases (Day, 2010). Theorist Campbell (2014) expressed his longing to have a term or label and its definition that rules out all the flaws, and recommended to embrace the term BIM with a question: *BIM - what's in a name?* The first hypothetical rationale for this research is that the 'key' is in this name - if seen in the right context.

BIM is not rocket science, but it is a complex interdisciplinary of *Building Science* and *Computer Science* and an advancing multidisciplinary area of study and practice. However, the issues, as mentioned earlier, are indeed barriers and gaps, and they prevent BIM from being developed into practice and literature effectively. Therefore, a solution is needed to break these barriers and to fix the issues. The re-establishment of the truth that is merely lost is a meaningful start to fix these gaps. This research attempts to prove the critical fitness of the phraseology of BIM and calls for changed usage of terminologies and approaches in the literature, contracts, and in standards

with the confidence of having theoretical backing. The findings of this objective being researched, contribute several defining conditions for BIM as an ideology.

1.1 Background

From early days, *Computer-Aided Drafting (CAD)* showcased three-dimensional graphics (Johnson, 1963) and also known as *Computer-Aided Design (Coons, 1963)*. The grounding idea of BIM was explained well by Eastman et al., (1974) decades ago under the phrasal *Building Description System – BDS*. A decade later, Ruffle (1986) readdressed the idea as “*increasing intelligence of computer-aided design by employing data structures that more closely represent the way buildings go together.*” Later Nederveen and Tolman (1992) used the terms *Building Information, Building Model* and *Modelling Building Information* for addressing an approach in which models are used to store and view information. Also, according to Charles Eastman, the industry called the idea as *3D parametric modelling of buildings* before calling it BIM (McGraw-Hill, 2012). Moreover, Autodesk (2002) states that the term *Building Graphic Modelling* was used earlier in place of BIM.

BIM was introduced well and described by Autodesk in a practical manner (Autodesk, 2002). Finally, by the efforts of Jerry Laiserin (Laiserin, 2002), in the first years of 21st century, the industry showcased a new name, term, tag, or a label called *Building Information Modelling (BIM)* to address the paradigm shift in Building Sector (Autodesk, 2003). Several terminologies attempt to marginalise the importance of BIM as a poor terminology, and these include *Integrated Project Delivery (IPD)*, *Information Management, Virtual Design and Construction (VDC)*, and more. Some see BIM growing as a core process methodology of *Information Management* in the Built Environment. For others, it is a tool in supporting other processes like *IPD or Digitisation*. Also, there are stimulations to have rather different terms than BIM for future such as *Building Information Optimisation and Artificial Intelligence BIM - AIBIM* (Allen, 2017). Yet the world is not in full agreement on what exactly is BIM.

2. LITERATURE REVIEW

The literature review begins with an ideological background of BIM along with a detailed report of its history chronologically. The investigation continues to address the interdisciplinary and multidisciplinary nature of BIM applications and the taxonomy wealth of the terminology.

2.1 Historical Perspective of the Concept of BIM

The mode of communication or exchanging the information in *Building* lifecycle has been transferred from paper to the computers gradually since the late 1950s. The *Sketchpad* was introduced as a *man-machine graphical communication* system (Sutherland, 1963). The *Drafting System* by International Business Machines – IBM was launched in 1965 as a “program that can be used by *any industry* to produce drawings as computer output”, this application included the “*information concerning all available material*”. From early days, the industry has developed the technology for both 2D drafting and 3D modelling under many products such as *CADAM - Computer-Augmented Design and Manufacturing* according to CAD Chronology by mbinfo.mbdesign.net.

Gingerich (1973) used the term *Computer Graphics Building Definition System – CGBDS*. This early literature refers to the idea of today’s BIM. In this, the computer system used designing algorithms with capabilities of handling graphical input, output, and changes of building data that helps the 2D drafting in defining the building floor using the reliable building database, then simulate the 2D models of building parts into 3D perspective projection. CGBDS developed a matured building database for design tasks and final construction, but it is more VDC for having focus only on design and construction. It is clear that the concept of *Generative Design* always existed within this idea of BIM since the very beginning. Therefore, the advancements in *Generative Design* in *Building* could be well addressed within BIM than confusing the future of BIM with terminological chaos.

Eastman et al.,(1974) used the term *Building Description System (BDS)* in which the idea was extended beyond and included building operation and renovation throughout its life. BDS helped to directly use the computer for numerical information while the printed drawings were used for spatial arrangements. According to Eastman et al.,(1974), BDS is the computer database that allows geometric, spatial, and property description operated by the user interface to produce models that are similar to the balsa wood models but in computer interactive graphic display. BDS was capable of handling input, output, change, sorting, manipulation, and analysis of the design information. It included algorithms in creating models, manipulation, and analysis. Here, both CGBDS and BDS looks close apart from Eastman et al.,(1974) connects the building operation and lifecycle. As a critical difference: Gingerich (1973) addressed it as *the simulation* of drafting, and Eastman et al.,(1974) addressed it as ‘model’ and

explained as similar to the one architects make with balsa wood. Gingerich (1973) discussed the word simulation as an algorithm-based graphics of something with function. However, the literature for BDS is popular and is considered as matching to the definition and the capabilities of what we call today a BIM (Goubau, 2017).

Intelligent Building Modelling by Ruffle (1986) indicated that the CAD needed to be advanced as *Computer-Aided Designing* by making the computers capable of *modelling* the possible and intelligent building solutions. Ruffle (1986) is using the word *representing* in contrast with the ‘manual representation’. The manual representation can be explained with an example of darting a wall in CAD using lines or closed polygon and a leader with a text that reads ‘WALL’. Here, we manually understand that the lines represent a wall. Therefore, Ruffle (1986) recommended employing the data structures or the structured data to represent more closely the way buildings go together while being *readable for both humans and machines*. Here, how the data is structured to make this intelligence is not explicit but refers to the word *Modelling*.

Nederveen and Tolman (1992) used the idea of *Building Models* to base the *Building Information*, and thus creating *Building Reference Models* to refer or represent the real case. However, this included a phrase *modelling building information* which is very close to the phrasal *Building Information Modelling*. Also, the paper left a keyword phrase “*Building Information Model*” but did not include any instance of this phrase inside; however, followed the idea of *Product Modelling*, *Building Product Modelling*, and *Building Data Modelling*. Somehow, this is reflecting the outcomes of ISO TC184 / SC4 resolution 32, Tokyo - December 1988. Papamichael et al., (1996) called it *Building Design Advisor (BDA)* and noted the *Object-Oriented model representation of building* for design while included the word *simulation* in a rather different context than *representation*. The industry called the idea as *3D parametric modelling of buildings* (McGraw-Hill, 2012). Unfortunately, even the present-day understand BIM as *modelling building information* where *Information Modelling* does not appear together as a terminology.

Computer Building Modelling (Galle, 1995) gives the idea of intelligent and compliant modelling of building using the capabilities of computers handling information and producing three-dimensional geometric models that are connected with drawings and sharing information to multiple interfaces. CBM illustrates the necessity of handling a huge amount of information produced progressively by design, construction, maintenance, and the coordination of contribution between the stakeholders. Galle (1995) pressed on *Semantic Integrity* of information that derives the consistency and coherency with its meaning (C.M. Eastman, 1981) and ensures the correctness of the information stored concerning matters represented as models (Charles M. Eastman, 1994). *Semantic Integrity* seems to be a necessary precondition for BIM. BIM Interoperability Expert Group (2020) explains this critical need as *Semantic Precision*.

The British Airport Authority was employed a thorough technology assessment to identify a suitable technology to integrate the whole lifecycle of projects since 1995 (Garrett, 2008). And Heathrow T5 project utilised several software tools such as *Autodesk Architectural Desktop* for parametric 3D models carrying information, *Navisworks* that allowed coordination and automated clash detection, and finally the asset information into *Maximo* (Garrett, 2008). However, T5 did not use any other terminology than CAD besides *Single Model Environment (SME)* - an equivalent for today’s *Common Data Environment (CDE)* - a central source of information from concept to completion and continued in operation. Nonetheless, SME in T5 was also identified as the whole innovative approach that involved digital prototyping and visualization, construction and operation with 4D modelling, and clash detection (Davies, Gann, & Douglas, 2009). It is observed here that the terms suggested in the earlier literature for such idea have not come to the practice successfully like BIM.

Virtual Design and Construction (VDC) is another term (Randy, 1996), VDC does not present much in literature, but it is one of the parallel terms with BIM. Moody (Online) explained VDC in a similar meaning of BIM. Also, there were names for such approach existed before 2002 they were tagged on the software companies - these include Bentley’s *Integrated Project Modelling*, and Graphisoft’s *Virtual Building Model* (Laiserin, 2002). Here, virtual or the real project are pressed with *Model* or *Modelling*, not significant as *Information Modelling*.

Autodesk’s Whitepaper on BIM (Autodesk, 2002) contributes well towards the practical idea of BIM. However, the concept of adding non-geometrical data to the geometrical models was referred as parametric modelling (Autodesk, 2002) even though the parametric modelling was addressed in earlier literature (Bettig & Shah, 2001) For example, parameter refers all data in Revit modeller. The term *parametric* possibly comes from Eastman et al.,(1974) - *parameterization* refers to the enabling of data in controlling the geometry. Leea, Sacksb and Eastman (2006) force it back to the initial idea and clarify the difference between the parametric data and the non-geometrical data. These differences explain the parametric or geometric and non-geometric information besides the geometric models. In a sense, any data can contribute to parametrization. The term *Building Graphics*

Modelling could not be found in the literature other than Autodesk whitepaper and thus seems to be a subverted support to present BIM as a brand-new idea, and possibly confused the theorists with non-sequitur fallacies.

NIBS (2007) addressed BIM as an emerging process and tool that supports many other processes but also included different terms for the acronym BIM such as *Building Information Model* and *Building Information Management* and notes that BIM is grounded in *Information Modelling*. These terms give the idea that BIM can be a product, a process, and the management of both. American Institute of Architects (AIA, 2007) has also presented the idea that BIM is one of the tools that IPD could include. However, The terms *Building Information Management* and the *Integrated Building Information Model (iBIM)* were presented in the recommendation to develop standard frameworks and guides further to BS 1192 (Richards, 2010). *Building Information System (BIS)* is one of the other terms used in ISO 29481-1 (2010). However, BSI (2013) and BSI (2014) are about *Information Management* for projects using BIM with an idea to employ tasks and procedures in generating activities to ensure the accuracy and integrity of information in projects that are using BIM, where BIM was noted as the *process of building* in general by using electronic Object-Oriented information. The *Object-Oriented Modelling* has wide application and objects refer to the information objects in classes rather than 3D building objects. Again, ISO 19650-1 and 2 (2018) are about *Information Management* using BIM considering organisation and digitalisation of information. Here, BIM is only a portion of the digitisation of building information. Somewhat, the collective idea is in circularity – the organisation of *Information* includes BIM, and the same BIM is used for the Management of the *Information* in circularity. Apparently, so far in review, the idea of *Information Management* seems to be similar with IPD rather than enabling BIM and possibly missing the point of the terminologies *Modelling and Information Modelling*.

2.2 Understanding the Interdisciplinary and Multidisciplinary Logics

BIM is an interdisciplinary area of study and practice. The new direction for interdisciplinary and multidisciplinary logic is the integrative disciplinary (Augsburg, 2016). The integrative thinking involves cognitive capabilities such as asking the meaningful questions, ability to reveal patterns and connection, the ability to create an integrative framework, holistic explanation, and more (Augsburg, 2016). However, to solve something interdisciplinary, “*a rigorous attempt to synthesise and integrate the ideas and methods of each pertinent discipline concerning the particular issue must be made*” (Fuchsman, 2009). The alignment of taxonomy and the understanding of the history of the development of such interdisciplinary subject are essential in interdisciplinary expressions (Augsburg, 2016). The *computer application theories should use the taxonomy notions* in a way that aligns in both *Computer Science* and the application domain while avoiding terminological chaos (Hanno & Hans, 1997).

We are moving towards *Semantic Web* in which the human task of accessing the information, extraction, and interpretation are shifted more towards machine-based automated services that depend on processable ontologies (Cross & Pal, 2008). The ontology in BIM for interoperability applications was studied by Abanda, Kamsu-Foguem, Tah (2017) and Abanda, Tah (2011) for different applications within BIM. Ontology is a coherent logical and ‘classification model’ that enables *Modelling of the Information* logically and coherently in *meta-modelling levels*, and it specifies a *shared vocabulary* (Cross & Pal, 2008).

Taxonomy is a hierarchical system of classification where ontology is simply the classification system (Cross & Pal, 2008). Taxonomy in theoretical or higher level is required to avoid terminological confusions in areas of application of *Computer Science* (Hanno & Hans, 1997). In general, the taxonomy levels are: firstly, the general category or the domain, then the general taxonomy organisation of the category, and finally, the first-order logics and then comes the internal relations (Cross & Pal, 2008).

Construction Informatics (Turk, 2006) is a potential alternative to the term BIM and was presented in the taxonomy of *Informatics*. Hanno and Hans (1997) note that *Informatics* is an alternative term for *Computer Science*. This note forces the research to revisit the terms *Computer Science* and *Informatics* to understand the origins of dilemma in applications such as BIM for ignoring the terminology of *Modelling and Information Modelling*. It is perceived that *Informatics* is an alternative term for *Computer Science* (Groth & MacKie-Mason, 2010). The term *Computer Science* was coined by academician Fein (1959) and unambiguously explained the computing and the data processing in computers. Fein (1959) included the terms *Information* and *Model*. *Information* was referred to “*data-gathering, storage, searching, classification, cataloguing, retrieval, encoding and decoding, interpretation, sampling, filtering, analysing, and checking*”. The *model* was referred to mathematical, algebraic, logical, computational, and statistical models. However, the theorists have proposed several alternative terms such as *Informatics, Computics, Data Science, and Datalogy* without any grounding explanation as Fein. The idea of ‘information and automatic’ called a domain as *informatique* in French, also the University of Karlsruhe in 1969 founded *Fakultaet fuer Informatik* which is translated as *Faculty of Computer Science* in English (Hecht-

NielsenReiner & Hartenstein, 2005). Eventually the term *Informatics* came back to English as foreign-friend referring an application of *Computer Science* and an alternative for *Information Modelling*. Here, the core mechanism *Modelling* is missing and being replaced by the word *Automatic*, which is a down side of this evolution. It is obvious that the industry isolates *Information* as though it comes by *Automatic* not necessarily by *Modelling*.

“A taxonomy is a collection of controlled vocabulary or terminologies organized into a hierarchical structure. Each term in a taxonomy is in one or more parent-child relationships to other terms in the taxonomy” (NIBS, 2007). *Built Environment* is a domain, and *Computer Science* is another domain; however, BIM is the integration of both. In interdisciplinary or multidisciplinary studies, the collaboration between the domains makes taxonomy a complex one, and thus needs consistency.

2.3 Understanding the Taxonomy of BIM

Until now, no literature has addressed the terminology BIM in a taxonomy within *Computer Science*. BIM is a first-order logic; NIBS (2007) discussed the taxonomy requirements only inside BIM as internal relations. The interdisciplinary nature shows *Computer Science* is the taxonomy domain. Yet, the fundamental concepts need to be addressed further in-order to identify the taxonomy organization between BIM and *Computer Science*.

GLIDE was one of the earliest languages for *Information Systems* (C. Eastman & Henrion, 1977). *Information Systems* can be explained as base *Data*, *Modelling*, and the produced *Information* in databases. In GLIDE, *shape models* represented the artefacts as solid bodies in the display. An *object model* is an extension of *shape models*. Object modelling includes information such as material, weight, and rigidity. Three-dimensional shape modelling was fully possible in early CAD systems, but they could not add an extension of object models. The gap fixed by GLIDE was the ability to model three-dimensional projection with data as parameters, and the ability to add object models to the shape models. An IBM White Paper titled the value of modeling clarified in 2004 that modelling is not only producing visual contents but also produces textual models.

Entity-Relationship (ER) and the *Object-Oriented (OO)* approaches for *Data Modelling* were studied by Shoval and Shiran (1997). In ER data modelling, data entities are stored separately and networked using relationships. For example, Department is an entity, and its Name and other details are separate individual attributes. Similarly, Employee is an entity, and his Name and other details are separate individual attributes. In ER, connections are formed between attributes and the entity, and another level of connection formed as a relationship between multiple entities. In the OO approach, the entities and its attributes and data sets are together form object classes. The object classes include its attributes and the relationships with the other Object-Classes (OC). The relationships with the other OC are also attributes but called ‘sets’. Department and Employee are objects and their Names and other details are separate attributes but stored within the objects, and further, a relationship can be represented by adding another set attribute called Department inside the object called Employee. Here the objects are representing a reality, the attributes are representing the object, and the sets are representing the relationships. An OC gives a simple picture of a *Data Model* and the fundamental of *Modelling* the data into an object model. It is clear that the OO applied universally, and the object model is not the shape model but the textual models predominantly.

The term *Information Model* or *Modelling* is part of ISO 10303-1(1994) as proposed in ISO TC184 / SC4 resolution 32, Tokyo - December 1988. *Information modelling* was explained as a representation of concepts, relationships, rules, constraints, and operation to stipulate data semantics for a chosen domain of discourse (Lee, 1999). *Information Models* provide sharable, stable, and organised modules of *Information* in a domain (Lee, 1999). *Data Modelling* and *Information Modelling* looks to be synonyms while studying both Lee (1999) and Shiran (1997). However, Shiran (1997) gives a key that the “OO approach requires critical paradigm shift..., in thinking from considering only the modelling of data to modelling both data and functions”. The function is referred to the transformation of data flowing between the applications of real-life processes; however, the functions are modelled over the objects – textual objects and their functions are the basis for *Information Modelling*.

The other important aspect of *Information Modelling* is the *Information Modelling Languages (IML)* such as *IDEFIX*, *EXPRESS*, *UML*, *EEML*, *VRML* and more. However, *EXPRESS* the IML was formalised for *STandard Exchange of Product – STEP* model data in ISO 10303-1(1994). The IMLs are representing the *Information Models*. *EXPRESS* is just the textual representation of *Information Models*, nothing about graphical representation. Therefore, the ISO 10303-11 (1994) included a subset to add graphical representation to the construct of *EXPRESS*. With this graphical subset, the modelling language is called *EXPRESS-G*. The IML itself is a construct of multiple computer *programming languages* such as Ada, C, C++, Modula-2, SQL, and the difference between modelling languages and programming language should be noted (Lee, 1999). Lee (1999) points out that *Modelling* is an iterative process of constructing models over models. The transformation and flow

of data between the represented real-life process and processing computer software systems eloquently produce *the Information as humans need* - thus the whole process construct becomes *Information Modelling*. The OO approach is just the present-day significance of *Information Modelling*, and we do not know what the future might bring. One can understand that *Modelling* is not only creating the 3D, but also the transformation of any information in different forms. However, the usage of the *Information* will not be possible without the continuous and progressive function of *Modelling* in *Information Modelling*. Thus, it is meaningful to consider *Information Modelling* as the taxonomy organization of BIM after *Computer Science* the taxonomy domain.

2.4 Understanding the Term BIM as Taxonomy Parent and Sibling

While the professionals deform the idea of BIM is into many terminologies such as *Building Information Management* or *Information Management* or *Project Information Modelling*, the industry fails to create BIM applied terminologies such as *GeoBIM*. *Geo-information Modelling* is a means of leveraging and controlling the *Information* in contrast and connection to GIS (Klimešová, 2006) in building geo-structures. Therefore, the term *GeoBIM* was coined in 2008 and sufficiently explained the need (Zobl & Marschallinger, 2008). *GeoBIM* is a useful term, and it signifies the BIM application as an early example of this kind.

The term *Marine Information Modelling (MIM)* used in the shipbuilding industry (SSI, 2015); however, this creates confusion with other terms such as *Marine Modelling*, *Marine Traffic Modelling*, and *Ocean Modelling*. It was noted as the buzzword, and the buzz of BIM reached shipbuilding industry (Luming & Singh, 2015); however, lack of mutual communication between the building and shipbuilding industries also noted; Such issues can be solved with the understanding of BIM in taxonomic order. This study suggests that a new term similar to *ShipBIM* and *MarineBIM* would be more meaningful than MIM in a way that signifies the application of a first-order logic such as BIM. However, there are more acronyms such as CIM for *City Information Modelling*, BrIM for *Bridge Information Modelling*, TIM for *Twon Information Modelling*, UIM for *Urban Information Modelling*, PIM for *Project Information Modelling*, AIM for *Asset Information Modelling* and more. These acronyms are truly confusing and tiring and missing the phenomenon of *Building and replace the term with simple nouns*.

BIM includes models of aircraft dealing with facilities such as airports; however, aircraft-building or automobile-building industries use their own modelling terminologies. Unified framework-based terminologies would greatly help those industries and building industry. The models can be exchanged with greater collaboration. *Aircraft Information Modelling* and *Automobile Information Modelling* are possible confusions for the future, according to this study. However, AircraftBIM looks confusing and indicates the ignorance of the ideology. ISO 10303-1 (1994) gives the idea of *Information Modelling* of products or *Product Information Modelling (PIM)*; however, BIM has been separated from PIM as terminology and closely connected with PIM in Process in the taxonomy organization of *Information Modelling*, but this does not mean that PIM can be ignored. *AircraftPIM* looks very meaningful if the ideology of PIM is not ignored. *Information Modelling* is recognised as a term since 1994 as a result of ISO 10303-1 (1994) along with extensive knowledge of IMLs. Though it was called PIM in the beginning, the term referred to everything that is produced or built. Almost everything humans produce or build fits within these two expressions: PIM and BIM, and they can work together and can share standards, and models and modelling platforms. BIM contents could initially be a PIM with a rich background of information. Apparently, the industry created expressions such as *BIM for manufacturers* in place of PIM and confused the acronym PIM with *Project Information Modelling* instead of labelling it a ProjectBIM - this violates the requirements for a coherent terminological system. *Information Modelling* is a taxonomy parent organization, and it could include many first-order logics such as BIM, PIM, and more. With this, we can understand that the internal taxonomy relationships such as *Generative Design* or *Digital Twin* or *Information Management* can work perfectly inside the umbrella of BIM and could also exist inside its taxonomy siblings and cross-connect or remain semantically connectable. In this context deprecation of terms could be considered for the present terms such as PIM and AIM violating the taxonomy order in compliance with ISO requirements for terminology works.

3. RESEARCH METHOD

The fundamental research tackles the concept and the logic of the research matter in a way that influences the applications and application research. This fundamental research has applied the qualitative analytical research method with the bottom-up inductive approach in collectively identifying the fundamentals from the concept field. This research deals with the history of the subject matter, collection of axioms, and philosophy of expressions and definitions. The multidisciplinary problem-solving has been equipped with a constant comparative technique. The constant comparative technique compares several opinions and checks their merit, hierarchy, and evolution in deriving the fundamentals of the given concept.

Analytical research is an in-depth study and evaluation of existing knowledge (Kothari, 1990) in an attempt to give a stipulative explanation to a complex phenomenon. Historical and ideological research to study the past to find the development of the phenomenon, and to understand the trends in the past to ground the present and to predict the future. The philosophical approach is employed to appraise the fundamental nature of the existing knowledge of the subject area. The constant comparative technique helped this research to capture the similarities and the differences as the phenomenon progressed with its terminologies to date from its conception as early as the term *Computer Sciences* was coined.

The ambiguous communication of terms and definitions cannot be solved without understanding the key issues. Therefore, this research needed to employ the bottom-up inductive research approach that investigates the key issues. Moreover, this part of the research lays the foundation to a later part to conduct a top-down deductive approach to re-establish the theory. Epistemology of Construction Informatics (El-Diraby, 2012) is an earlier attempt to solve the same issue and could not intervene the matter much. It was a direct epistemological attempt without taking note of the historical development of the concept. Table.1 presents the research design indicating the bottom-up approach. The analytical basis is the abstract of concerns used collectively in this study. This research framework and the paper presents only the first half of the research. The second part continues the framework using the same analytical base but with a top-down refinement of the fundamentals generalized here.

Table 1: Research Framework

Analytical Research (Inductive/ Bottom-up Approach)	Review of Literature (Analytical Basis)
● 5. Illuminate the maturity or fitness	History
↑ 4. Scrutinize the idea	Axioms
↑ 3. Generalise concept field and terminology base	Possibilities
↑ 2. Trace the history and possibilities in future	Philosophy in Context
○ 1. Gather information	Problem Solving

The literature needed to conduct this research has been collected from several peer-reviewed journal articles, conference papers, authorized industry documents and websites, and the reports from industry leaders. Epistemology helped to realise the concept field, validity, scope, and distinction between justification and opinion. Etymology helped to realise the ideological developments with regards to the terminologies and lexicons. And referring the possible evolution and workability in future was also utilized to generalise the idea into defining fundamentals. Scrutinizing the idea is a mechanism to identify the worth of the opinions based on analytical rules and justifications regardless of its popularity, authorisation, and appeals. Illuminating the maturity solves the present dilemma by showing the fitness of the term BIM with the subject idea in a systematic ideology.

In connection with the second part of this research, the concept field has been analysed using the Nvivo qualitative data analysis software. Several documents have been loaded into the software to produce analytical insights in the form of word frequency clouds and word trees. The following table gives an example of how the data was analysed.

Table 2: Example of data analysis

Early literature on this idea focused on <i>Building</i> and Data	The present focus on <i>Information</i> and <i>Information Management</i>	This research is making a balanced focus.

This study on fundamentals predominantly deals with terminologies, concepts, and definitions – therefore, the requirements for terminology works such as ISO 704-2009 and ISO 1087-2019 and the related philosophy of logics have been considered as a mechanism for problem-solving. Thus, recommendations of this research are not based on the opinions itself but based on the validity and justifications.

4. RESULTS AND DISCUSSION

This research notes that the world is not fully in agreement with the usage of the term BIM. The word *Building* needs to be understood beyond a noun or verb but refers to the routine of humans in the lifecycle of building as a broader concept and phenomenon. *Information* is a necessary condition in BIM; however, it is only the way in which humans can interpret, unlike machines while dealing with models. Presently, the meaning of the word *Modelling* has been marginalised, where it supposed to be the fundamental precondition of BIM to deal with models in every phase of its existence. Data lives in the core of BIM and helps towards the *Datafied* business and life - a global movement such as *Semantic Web*, Robotics and machine controls, IoT and Digital Twins, AI and Machine Learning. *Digitisation* and *Datafication* are terminologies refer almost the same idea; however, *Datafication*, a borrowed term, takes a higher rank in context as a quasi-synonym in setting the direction for BIM.

The research has traced the words comprising the phrase *Building Information Modelling* to an extend of sufficiency to conclude that the terminology BIM is critically fit and profound in a recognised taxonomy order. Clear visibility of the connection between the term and the meaning it implies has been established in this study. The research identifies that the terminology BIM is not just the phrase of three words; instead, it is a construct of three critical terminologies. *Building* is a terminology as capitonym that represents the domain of *Building Science* and *Modelling* is a terminology that represents *Computer Science*; however, *Information* is a terminology that defines human interaction and decision making between the other two. In taxonomy organization, *Information Modelling* is a terminology where BIM fits perfectly in the taxonomy domains of both *Computer Science* and *Building Science*. BIM is not the dead-end of its taxonomy order, nor the only child of its taxonomy parent, the application of BIM has been further understood into speciality areas and lifecycle phrases as internal taxonomy relations. A systematic and unified way of indicating its taxonomy children has been proposed in this paper. This helps to avoid terminological conflicts and parallel developments with reduced collaboration.

Common issues, perceptions, and the possible truths are identified qualitatively, and they reveal that the present understanding of BIM is isolated within the dogma of the terminology *Information*. Thus, provoked this research to address the other two words *Building* and *Modelling*. BIM is a complex phenomenon, and therefore, it is hard to express the meanings outside the context of its natural settings. Therefore, in this research, the natural context of BIM has been established as the *Computer Science* and its taxonomic *Information modelling* applied in aid of 'humans in the lifecycle of Building'.

The word *Building* is both noun and verb or a gerund, but fortunately a terminology in BIM. This section extends the meaning of *Building* beyond it had been addressed ever. Earlier literature has considered 'building' as 'spatial composition and artefacts' which included ships and machines too. But the latest ones arguably limited this as buildings and civil engineering works as nouns. The building industry was blamed for having poor communication and sharing with the shipbuilding industry with regards to BIM. Building and BIM can be common to any industry if they build. The word *Building* can be anything that is buildable regardless of the industry divisions; however, the possible confusion here is 'building versus manufacturing', and solved in a later section. This sets-up the necessary relationship of *Building Lifecycle* with the *Product Lifecycle*.

The verb building was treated only as construction in the past. The idea of 'design and build' contracts make it broader. The idea of 'design, build, and operate' extends it further; however, it is somewhat incomplete. As the world grows in civilisation, the verb building can be expected to provide a far-reaching understanding of the philosophy of human life in the lifecycle of building as a continuous activity with learning. For humans, *Building* is the lifecycle process dealing with spatial compositions that include designing, constructing, using or operating, maintaining, upgrading, renovating, deconstructing, recycling, and re-building throughout generations while contributing to the *Body of Knowledge* in every phase. Moreover, the knowledge gained in *Building* lifecycle goes beyond time and industry and involve every human life and business. The term *Building* refers to the various types of things that are built even beyond the scope of *Built Environment*, challenging the industry level collaboration boundary to go global. Also, *Building* refers to the different phases of *Building* lifecycle and as well as the specialist professional areas such as architectural and structural.

Building in virtual environments connects the knowledge lifecycle with real-world *Building*. Initially, the spatial

compositions are built virtually in BIM. An ancient township can be built virtually. The knowledge from real-world could remain in virtual experiences even after the life of an asset. These possibilities connect the idea of '*humans in the lifecycle of Building*' with virtuality - before and beyond the real-life experiences. *Building* experiences in virtual environments are realised to produce mixed and extended realities with real-world *Building* activities (Allen, 2017). The knowledge grows into virtual, into virtual experiences, and progressed into augmented experiences, and then progressed into enabling and enhancing the real-world *Building* activities. Now, referring the terminology of *Building* to the forward-thinking principle of having it for *Sustainability* brings a whole new purpose for BIM as recommended by (Snook, 2016). While BIM is an application of *Information Modelling*, it is applied in aid of humans in the sustainable lifecycle of *Building*.

Information refers to the structuring or *Modeling* the data in a form that humans can comprehend. *Information* cannot exist if there is no *Modelling*, where the *Modelling* can be *Data Modelling* or *Information Modelling* in this context. *Information dynamics* is noted as deficient in BIM (El-Diraby, 2012). This term can be understood as the *flow and the transformation of Information* while the earlier explanations called *Modelling* as the *flow and the transformation of data* (Shoval & Shiran, 1997). The connection between the 'transformation of data' and the 'transformation of information' seems to be ignored. However, it was noted that modelling is an iterative process (Lee, 1999). The first iterations models the data into *Information* or function, or a reference and the nth iterations uses the earlier produced models or existing information and possibly along with some amount of fresh data to build upon or modify the existing models. This explains that iterative *Modelling* is transforming *Information* and the data. Therefore, *Modelling* makes the information dynamic. However, this shall be understood as a simulation than representation. Thinking of 3D models is only a small aspect of the whole *Modelling* phenomenon.

The *Information Model* includes much more than data and refers to something with the potential to go dynamic. Delivery of *Information* refers to something static in nature. The act of *Building* produces spatial compositions or a building, for example, the act of *Modelling* produces a model in the terminology of BIM, and then what action produces *Information*? Creating or producing? None exactly but it is *Modelling* of course, if not, the terms such as *Information Modelling* and *Data Modelling* are meaningless. *Information Management* could be the function of creating, using, and managing the information. However, *Information Modelling* is an evolved form of *Information Management*. The evolution suggests that *Information Management* could exist in its unevolved form; however, it cannot manage *Information Modelling* without predominantly embracing the phenomenon of *Modelling* and work within. Systematic *Modelling* with *Semantic Integrity* voids the need for the information being managed.

Information Modelling is the process and technology mechanism regardless of what we apply with this. The application of *Information Modelling* can be a *Digital Twin* or an Intelligent CAD action, or the *Modeling* of changes as an evolved form of *Change Management*; however, anything that applies *Information Modelling* to aid the lifecycle phenomenon of *Building* may come connectable in BIM. The management of *Information Modelling* can be called as *Information Modelling Management (IMM)* to show the significance of evolution and to avoid non-sequitur fallacies - respectively BIMM. Ultimately, *Information Modelling* is the evolved form of *Information Management*, and logically the governance must be done within to avoid impossible word condition of a phenomenon or expression in respect to the philosophy and requirements of logics. The term BIM is not just a three-letter acronym that refers to three words phrase, but it is about two terminologies representing two domains taxonomically. The *Building*, and the *Information Modelling* makes-up the term BIM. All three words also carry three different weighty terminologies independently; however, the *Information* could not be generated or used without the function of *Modelling* predominantly – therefore, they go together.

Information is just a form or manifestation of its existence during its lifecycle, but originally it was only the data and its enablers. *Models* comprise but contain the information while *Modelling* is not active. While it is *Modelling* or model as verb or process, it can be abbreviated as 'BIM' - all capital letters - to mean *Building Information Modelling*, because the (I) *Information* is manifested, and (M) *Modelling* is active. While referring model as noun or product, it can be abbreviated as 'BiM' with lower case 'i', because the *Information* is not being manifested in simulation for humans, or the data in *Information Models* are not being supplied to the machines at this state. This proposal should not be strange since we already apply the similar principle in writing the acronyms such as COBie (*Construction Operation Building Information Exchange*) where 'i' refers to the *Information Model* being delivered in a passive form where the function of *Modelling* is not active. Here, the BiM can be stored and transferred or delivered without being transformed. BiM the package becomes BIM the process again while being transformed or the *Modelling* comes active again. The other styles Bim or bim are truly misleading since they are words or idioms with different meanings. As such, DesignBiM, ProjectBiM, AssetBiM, or similar ones can refer the information delivery. The whole process with relevant management functions can be noted with an acronym BIMM and expand as 'Building Information Modelling and Management'. According to ISO TC184 / SC4

resolution 32, Tokyo - December 1988 as implemented in ISO 10303-1 (1994), *Information Modelling* shall be applied in various applications such as *Building* or aeronautical or marine *Modelling*; however, the idea is to have a common *Product Information Model* and use it connectively with other application domains of *Information Modelling* such as BIM. Therefore, products or things need their own STEP compliant *Information Model* before it can be added to BIM or *Aeronautical Information Modelling* or *Flood Information Modelling*. This is a favouring the idea for today's interest on *Digital Twins and Digital Treads* where all things come together in bi-directional replica or simulation between real and virtual worlds under the application of *Information Modelling* or BIM concerning the phenomenon of *Building* with natural and artificial things over the natural or artificial environments.

The ideological movement shows that the earliest view in this concept was focusing on *Building* using the data and software systems. The present developments have shifted the focus into *Information* or *Information Management*. Therefore, the future focus may turn into *Modelling* based on the justifications discussed earlier since the *Information* does not compel the existence of *Modelling*, but the *Modelling* comes with a compelling condition to deal with *Information*. Notwithstanding the possible shift, this research recommends that the focus shall be given to *Information Modelling* collectively than separately as *Information* or *Modelling* to avoid confusions in taxonomy order of *Modelling* in context. The terminological organization need to be harmonised and coherent. Therefore, possibilities in phraseology for the acronym BIM in this context need to be harmonized as *Building Information Modelling*. However, practice implications need to signify the meaningful variations.

This research recommends using meaningful and systematically coherent acronyms such as *BIM for Building Information Modelling*, and *BiM* with a lower case 'i' for *Building Information Model*, and *PIM for Product Information Modelling*. This study also recommends avoiding the use of non-taxonomy driven terminologies such as *Project Information Model*, *Asset Information Model*, or *Design Information Model*. However, such needs can be expressed under the taxonomy of BIM as *ProjectBIM* or *ProjectPIM*, *AssetBIM*, *AircraftPIM*, *DesignBIM*, *BridgeBIM*, *StructuralBIM*, *CityBIM*, and as many as needed. And realises that these new terminologies would not confuse even if the pattern is used for the delivery of models as *DesignBiM*, *ProjectBiM*, or *BuiltBiM* with lower case 'i'. This proposal helps not to confuse *Information Management* of building with *Information Modelling* of *Building* since they both do the same thing according to the theory; however, this needs to be taken further with the realisation that the latter is the evolution of the former. Conflicting terminologies that are present in practice and frameworks could be deprecated considering the requirements of terminology works.

The terminological evolution of BIM is critically sufficient and might even carry all the further evolutions for centuries unless we introduce terminological chaos without respecting the philosophy of logics. The terminologies referring the idea of BIM have evolved since the introduction of computers until the term *Information Modelling* was recognized during the 1990s and finally culminated as BIM since Autodesk presented the Whitepaper in 2002. Laiserin Jerry can be called the Iron-Man of BIM for his extraordinary efforts to bring the industry leaders together and establishing BIM as a terminology for the paradigm shift in *Building*. Seeing BIM in a taxonomically profound order, and being galvanized out of the long-standing theoretical coherency – the term *Information Modelling* and BIM has secured a superlative position than its taxonomy relatives being suggested or imposed as terminological alternatives. For example, *digitization of information about buildings* is not addressing its mechanism, and the word '*buildings*' is referring to a noun in a way that limits its application. One of the limitations realized in this research is that the *digitization* of a thing (*Building* as a noun) limits its understanding from leveraging the *Modelling* of actions or processes and connecting them to the things that are both in virtual and real-world. Here, the *digitization of information* refers to the mechanism of *Information Modelling*.

BIM as a taxonomy parent is used to produce many actions as taxonomy children such as 1D, 2D, 3D, 4D, 5D, 6D, 7D, nD, VDC, IPD, *Information Management*, and *Digital Twin* and more under the umbrella of *Information Modeling*. If that is the case, the concept *Information Management using Building Information Modelling* is either referring only a small application of *BIM* or creating an impossible world condition in circularity which is a fallacy in expressions. While the digital concepts such as *Digital Twin*, *Golden Thread*, *Generative Design*, or the advanced *CAD* becomes the application of *Information Modelling*, BIM creates the umbrella for these applications of *Information Modelling* in the domain of *Building*. However, *Information Management* is one of the enablers of BIM while being enabled and leveraged in all these applications using the mechanism or principle of *Modelling* or *Information Modelling*.

5. CONCLUSION

This research was an extensive attempt to establish the critical fitness of the terminology BIM, the aim which is to illuminate ideological evolution and its sufficient state of maturity has been achieved very well. The conclusions

are disruptive with a forward-thinking principle to support the present workability of the subject idea and its evolution further. The terminology BIM was poorly conceptualized and suffered ambiguities and criticism. The problem was not only the misunderstanding of the terminology but also how the implied meaning has been communicated across the literature, policies and practice. This research has demystified the real potential of the term BIM. However, the second problem is the absence of a unified meaning in defining or describing what BIM is. The presentation in this paper is only one side of the coin, but an *Intentional Definition* that stipulates its necessary and sufficient conditions is the other side helping the industry in the right direction to embrace the term BIM with clarity. Confusions between BIM and other meaningful digital concepts such as *Generative Design* with the help of algorithms are clarified to continue within BIM collaboratively than creating terminological chaos.

The terminology of BIM is comprising of two terminologies *Building* and *Information Modelling*. *The terminology of Information Modelling* is comprising of two parts - *Information and Modelling* where the *Information* is a form of a model that favours human interpretation and comprehension but comes to exist with the action of *Modelling*, and *Modelling* is the mechanism or the function of dealing with *Information* to the present state of evolution. *Building* is the lifecycle phenomenon of humans dealing with the things that are considered as spatial compositions in real or virtual environments. The phenomenon of *Building* clarify various types of things such as a bridge or hospital or house or ship or a walkway that we can build using the natural and human-made products; however, the phenomenon lays a lateral layer of phases to each of its types and involving various specialist fields such as architectural and building systems (MEP). The terminology of BIM predominantly refers to the phrasal *Building Information Modelling* in this context; however, the other healthy variation is *Building Information Model* which could to be denoted as BiM with a lower case 'i' as in COBie to allow coherency and terminology harmonisation. Taxonomically aligning the internal relations of BIM, the terminologies can be leveraged as having BIM or BiM as a suffix for applications such as ProjectBIM or DesignBIM or DesignBiM or OperationBIM referring a phase, BridgeBIM or ShipBIM or PlantBIM or ReservoirBIM concerning various types, ArchitecturalBIM or ArchitecturalBiM or HeritageBIM or StructuralBIM concerning several specialities in the profession. Deprecation of terms needs to be considered for the present terms violating taxonomy order. The study also clarifies that *Product Information Modelling (PIM)* is a taxonomy sibling with BIM, and requires re-establishment and seamless collaboration to promote BIM into sustainable building lifecycle process. The direction of moving forward with *Datafied* life and business innovations referring the digital concepts such as CAD, IoT and *Digital Twin* within the umbrella of *Information Modelling as co-existing first-order logics and work collaboratively with BIM*.

6. REFERENCES

- Abanda, F. H., Kamsu-Foguem, B., & Taha, J. H. M. (2017). BIM – New rules of measurement ontology for construction cost estimation. *Engineering Science and Technology, an International Journal*, 20(2), 443-459.
- Abanda, H. F., & Tah, J. H. M. (2011). Sustainable building technology knowledge representation: Using Semantic Web techniques. *Advanced Engineering Informatics*, 25(3), 547-558.
- AIA. (2007). *Integrated Project Delivery: A Guide* [1].
- Allen, B. (2017). The Future of BIM Will Not Be BIM and It's Coming Faster Than You Think: How Software Algorithms and Robotics Will Drastically Change the Design/Build Process. *Autodesk University*.
- Augsburg, T. (2016). *Becoming Interdisciplinary: An Introduction to Interdisciplinary Studies* (3 ed.). Dubuque: Kendall Hunt Publishing Company.
- Autodesk. (2002). Autodesk Building Industry Solutions:Building Information Modeling. In *White Paper*: Autodesk, Inc.
- Autodesk. (2003). Building Information Modelling for Sustainable Design. In *White Paper*: Autodesk, Inc.
- Bettig, B., & Shah, J. (2001). Derivation of a standard set of geometric constraints for parametric modeling and data exchange. *Computer-Aided Design*, 33, 17 to 33.
- BSI. (2013). PAS 1192-2 Specification for information management for the capital/delivery phase of construction projects using building information modelling. In: The British Standards Institution.
- BSI. (2014). *PAS 1192-3 Specification for information management for the operational phase of assets using*

building information modelling.

- Coons, S. A. (1963). *An Outline of the Requirements for a Computer-Aided Design System*. Paper presented at the Spring joint Computer Conference, Michigan.
- Cross, V., & Pal, A. (2008). An ontology analysis tool. *International Journal of General Systems*, 37(1), 7–44.
- Davies, A., Gann, D., & Douglas, T. (2009). Innovation in Megaprojects: Systems Integration at London Heathrow Terminal 5. *California Management Review*, 51(2), 101-125.
- Eastman, C., Fisher, D., Lafue, G., Lividini, J., Stoker, D., & Yessios, C. (1974). *An Outline of the Building Description System*.
- Eastman, C., & Henrion, M. (1977). GLIDE: A Language for Design Information Systems. *ACM SIGGRAPH Computer Graphics*.
- Eastman, C. M. (1981). *Recent developments in representation in the science of design*. Paper presented at the Proceedings - Design Automation Conference.
- Eastman, C. M. (1994). Managing integrity in design information flows. *Computer-Aided Design*, 28(6), 551-565.
- El-Diraby, T. E. (2012). Epistemology of Construction Informatics. *Journal of Construction Engineering and Management*, 138(1), 53-65.
- Fein, L. (1959). The role of the University in computers, data processing, and related fields *Communications of the ACM - CACM Homepage archive*, 2(9), 7-14.
- Fuchsman, K. (2009). Rethinking Integration in Interdisciplinary studies. *Issues Integrative Studies*, 27, 70-85.
- Galle, P. (1995). Towards integrated, “intelligent”, and compliant computer modelling of buildings. *Automation in Construction*, 4, 189-211.
- Garrett, B. (2008). Building Information Modelling (BIM) technology for Architecture, Engineering and Construction: Heathrow Terminal 5. In: AEC Magazine.
- Gingerich, J. Z. (1973, 06/25/1973). *Computer Graphics Building Definition System*. Paper presented at the Proceedings of the 10th Design Automation Workshop.
- Goubau, T. (2017). A History of BIM. *Collaboration*.
- Groth, D. P., & MacKie-Mason, J. K. (2010). Why an Informatics Degree? , 53(2), 26-28.
- Hanno, W., & Hans, M. (1997). *A taxonomy for computer science*. Paper presented at the International Conference on Informatics as a Discipline and in Other Disciplines: waht is common?, Enschede, The Netherlands.
- Hecht-NielsenReiner, R., & Hartenstein, H. (2005). Eulogy: 1917 Karl Steinbuch 2005.
- ISO 10303-1. (1994). Industrial Automation Systems and Integration - Product Data Representation and Exchange - Part 1: Overview and Fundamental Principles. In: International Organization for Standardization.
- ISO 10303-11. (1994). Industrial automation systems and integration - Product data representation and exchange - Part 11: Description methods: The EXPRESS language reference manual. In.
- ISO 19650-1. (2018). Organization and digitization of information about buildings and civil engineering works, including building information modelling (BIM) - Information management using building information modelling - Part 1: Concepts and principles. In (Vol. 1): The British Standards Institution.
- ISO 29481-1. (2010). ISO 29481-1 Building information models - Information delivery manual - Part 1: Methodology and format. In: International Organization for Standardization.
- Johnson, T. E. (1963). *Sketchpad III: a computer program for drawing in three dimensions*. Paper presented at the Spring joint computer conference, Michigan.
- Klimešová, D. (2006). *Control GIS and geo-information modelling*. Paper presented at the 8th WSEAS

- international conference on Automatic control, modeling & simulation, Czech Republic.
- Kothari, C. R. (1990). *Research Methodology: Methods and Techniques*. In (2 ed.). Chennai: New Age International (P) Limited Publishers.
- Laiserin, J. (2002). Laiserin letter: Comparing Pommes and Naranjas. Retrieved from <http://www.laiserin.com/features/issue15/feature01.php>
- Lee, Y. T. (1999). *Information Modeling: From Design to Implementation*. In.
- Leea, G., Sacksb, R., & Eastmanan, C. M. (2006). Specifying parametric building object behavior (BOB) for a building information modeling system. *Automation in Construction*, 15(6), 758-776.
- Luming, R., & Singh, V. (2015). *Comparing BIM in Construction with 3D Modeling in Shipbuilding Industries: Is the Grass Greener on the Other Side?* Paper presented at the IFIP International Conference on Product Lifecycle Management. https://link.springer.com/chapter/10.1007/978-3-319-33111-9_18
- McGraw-Hill. (2012). *The Business Value of BIM in North America: Multi-Year Trend Analysis and User Ratings (2007-2012) McGraw-Hill Construction*. Retrieved from Belford MA, USA:
- Moody, D. (Online). *Virtual Design & Construction: The Changing Role of a Coordinator*. In: BIMForum The US Chapter of BuildingSMART International.
- Nederveen, G., & Tolman, F. (1992). Automation in Construction: Modelling multiple views on buildings. *International Council for Research Innovation in Building Construction*, 1, 215-224.
- Papamichael, K., LaPorta, J., Chauvet, H., Collins, D., Trzcinski, T., Thorpe, J., & Selkowitz, S. (1996). *The Building Design Advisor*. Paper presented at the ACADIA 1996 Conference, Berkeley, California 94720.
- Randy, B. (1996). Virtual building. (computerized building design, construction and management). *Buildings*, 90(3), 76.
- Richards, M. (2010). *Building Informatin Management: A Standard Framework and Guide to BS 1192*. In: British Standard Institution.
- Ruffle, S. (1986). Architectural design exposed: from computer-aided drawing to computer-aided design. *Environment and Planning and Design*, 13(4), 385-389.
- Shoval, P., & Shiran, S. (1997). Entity-relationship and object-oriented data modeling - an experimental comparison of design quality. *Data & Engineering*(21), 297-315.
- Snook, K. (2016). BIM - it's about the Planet - Parts 1 to 5. Retrieved from https://www.designingbuildings.co.uk/wiki/BIM_-_it%27s_about_the_Planet_-_Part_1
- SSI. (2015). SSI Showcases Marine Information Model at FMMS. Retrieved from <http://www.ssi-corporate.com/company/news-and-events/2973-ssi-showcases-marine-information-model-at-fmms>
- Sutherland, I., E. (1963). *Sketchpad, A man-machine graphical communication system*. (PHD). Massachusettsi's Institute of Technology
- Turk, Z. (2006). Construction informatics: Definition and ontology. *Advanced Engineering Informatics*, 20, 187–199.
- Zobl, F., & Marschallinger, R. (2008). Subsurface Geo Building Information Modelling: GeoBIM. In: *Geo Informatics*.

TOWARDS BIM-BASED ASSEMBLY CAPACITY ANALYSIS FOR COMMUNITY CONSTRUCTION SITE PLANNING AND SIMULATION

Wei Zhou & Praveen Pushpala

Digital Engineering Centre, Country Garden Pacificview Sdn. Bhd., Malaysia

Email: mr.zhou.wei@gmail.com, praveenpushpala@countrygarden.com.cn

ABSTRACT: *Four-dimensional (4D) modelling is considered an effective technique in building information modelling (BIM) to simulate project process for robust construction plan generation. In the field of design for manufacture and assembly (DfMA), 4D has potentials to help assembly building projects to create community construction site planning, which however asks for effective synthesis of both design at an object level and construction at an operational level. Targeting this challenge, this paper discusses 3D BIM model adoption for erection sequence creation through the relationship analysis between crane lifting capacity and precast concrete component's attributes for low-rise building construction. As such, it leads to individual projects' site layout by considering selected crane lifting position, boom extension range and lorry parking location for precast components on-site delivery. The clarified design precast components' attributes and crane working requirements are positive to the overall community construction site layout planning using macro 4D modelling. The assembly building project is therefore able to have optimal operation by effectively coordinating related supply chain in the DfMA.*

KEYWORDS: *4D modelling, BIM, community construction site planning, DfMA, erection sequence.*

1. BACKGROUND

The current architecture, engineering, construction and operation (AECO) industry has more opportunities than ever to change the traditional project delivery approach to be digitised, sustainable and cost effective in today's digital era. Building information modelling (BIM) as one of enablers has demonstrated a holistic solution to accelerate this digital transformation. The AECO industry therefore aligns increasingly with some pioneer industries like manufacturing, aerospace, nuclear energy, etc. to adopt the digital technologies into its all phases of building life cycle to achieve the digital twin (Bolton et al, 2018). For achieving this aim, government authorities in the world and international standard organisation (ISO) provide practitioners with standards and regulations (e.g. ISO 19650) as guidance from multi-faceted perspectives of data, application and information management to implement BIM.

The industry building system (IBS) is considered a vital impetus to modernise the AECO industry. It features detailed BIM design, manufacturing, logistics with final onsite assembly work. Given this coherent working process, the BIM design as upper stream input drives the downstream workflow so that the detailed design data can satisfy the manufacturing requirements to precisely control related system actions. Such an automated and integrated process is discussed in the domain of design for manufacturing and assembly (DfMA) (Tan et al, 2020), in which independent precast concrete/steel manufacturing can be completed in a factory situation. Unlike cast-in-place projects, the assembly project onsite work is only left for operating prefabricated components for assembly without much wet operations and wastes being incurred. Because the precast work needs to be finished in advance, to obtain predefined erection sequence of the precast components is critical for both factory manufacturing and onsite assembly.

The predefined erection sequence generation by applying 4D modelling can provide assemble projects with not only production order for off-site manufacturing in the factory but also robust assembly sequence for on-site erection coordination. In the BIM application, 4D modelling is typically regarded as 3D model plus time dimension to simulate a construction process so that planners have chances to exam their schedules for better project delivery planning. Along with this application trajectory, a number of projects are reported its usefulness in the areas of health & safety (Sulankivi, 2010), resource allocation on site (Li et al., 2009), environmental planning and management (Jupp, 2017), etc. Considering erection sequence order associated with work break structure (WBS) is prior to time-based scheduling, 4D modelling for this particular issue is more concerned about operational level issues like crane lifting capacity, individual precast concrete/steel components and their collaboration in DfMA (Kang et al, 2010).

The erection sequence generation impacts on community construction site layout planning greatly because it is heavily related to the crane lifting work in not only vertical but also horizontal directions. In the vertical direction, the crane lifting capacity is associated with individual assembly projects and its involved precast components' locations and loads (Wu et al., 2020). In the horizontal direction on the other hand, the neighbour projects have spatial influences on effectiveness and efficiency of crane lifting work and moving. Within the community construction site scope with multiple low-rise buildings, only considering both vertical and horizontal influences in one solution can assembly work be clarified to help generating multiple projects' onsite layout planning. This community site layout planning work will become tedious and complex along with multiple project types variations and multiple locations that lead to spatial correlation. Therefore, seeking an automated approach to the construction site layout is crucial to satisfy multiple low-rise assembly projects in a community construction site.

The aim of this paper is to discuss a BIM-based spatial analysis possibility for precast low-rise building assembly so as to automate community site layout planning. Section two reviews the current approaches to construction site planning and assembly work. Subsequently, it discusses DfMA-compliant community site layout planning to identify influential factors in considering relevant solutions. Section four focuses on the Trimble Tekla assembly utilities as case study to highlight related advantages and disadvantages to be potential solutions' features. The last section draws a conclusion to identify the future investigation and validation.

2. STATE-OF-THE-ART

Construction site layout planning is a critical task for construction projects. Its complexity lies in not only dynamic issues to be decided like onsite traffic, resource allocation, operators' movements etc. but also static and temporary material storage, facilities and building components' layout arrangement. All these issues contribute to the difficulty of making construction site planning which traditionally relies on professionals' personal knowledge and experiences at large. Leveraging the advancement of information communication technology (ICT) and more advanced digital technologies like BIM increasingly attract researchers' interests in coping this challenge.

Kang et al. (2006) summaries crane investigations in applying ICT and proposes the iCrane prototype for automating crane erection process (Fig. 1). Being dependent on the developed algorithm in the research, it is able to find collision-free erection paths of each structural element and coordinate the motions between multiple cranes to generate both project schedule and the simulation of erection processes at an operational level. The prototype targets inputted structure analysis models from SAP2000 and be developed from scratch. The research highlights important considerations of motion planning for multiple crane collaboration on site and erection path according to the crane capacity to gain both project schedule and simulation. However, this study neither adopts emerging smart BIM data into multiple crane collaboration studies nor extents to explore construction site layout planning. Therefore, it is necessary to reconsider possibilities to clarify relevant solutions.

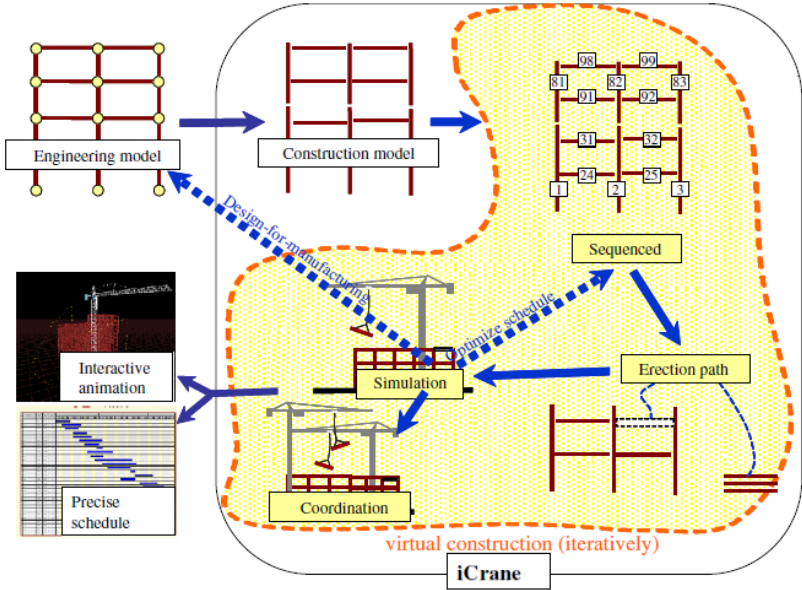


Fig. 1: Workflow of the iCrane prototype (Kang et al., 2006).

Schwabe et al (2019) propose a rule-based model checking approach to construction site planning. It takes the advantage of industrial foundation classes (IFC) to be checked by the BIM query language based on the rule engine Drolls support. This fully automated attempt in construction site planning explores the potentials of applying sophisticated BIM-based rule checking mechanism to create construction site planning. Nevertheless, as a pioneer study, the research considers fewer issues from peripheral crane types' influences like locations, lifting capacities, etc. which are heavily involved into precast component layout planning and dynamic crane lifting work. Within the BIM domain, external crane issues are normally out of the focus of attention in project information model (PIM) creation. This makes the research worth being enhanced further in the crane aspects.

Ahamed et al. (2012) propose a prototype to consider the mobile crane working space as engineering constraints for motion planning of route path and near real-time construction simulation. Simultaneously, Zhang et al. (2012) propose a dynamic motion planning algorithm to ensure safety during the execution stage by quickly re-planning and avoiding collisions as well as searching better solutions by improving path smoothness and reducing path execution time (Fig. 2). Both studies provide useful insights to link precast component layout considerations as extensible study for potential site planning and can be enhanced further by adopting the BIM data.

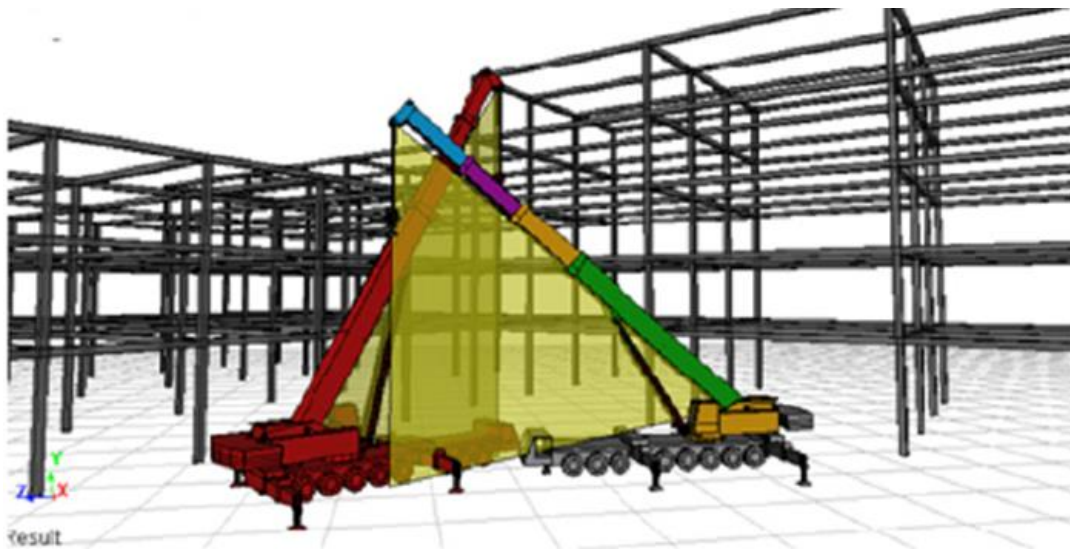


Fig. 2: Mobile crane motion planning simulation (Zhang et al., 2012)

From a data perspective, efforts have been put into the level of detail (LoD) for construction site elements (Cassano et al, 2017) and construction site information model (CoSIM) (Trani et al, 2016) so that the relationship between construction site and BIM data can be established tightly. As part of BIM, the PIM creation and delivery centralises around the building product from the design. This inspires the construction site model development to concretise related elements like cranes in line with the LoD definition from LoD 200 to LoD 500 for different phase applications. Besides basic site elements, it is recognised that site layout planning in professional practices is quite experience oriented that applying BIM models for site template creation can help to capture the planners' knowledge. The proposed CoSIM provides a series of templates to guide management activities in construction projects to apply relevant BIM data at different LoDs.

Indicated from the above literature, they are three significant pitfalls in the current construction site layout planning. The DfMA in the assembly buildings has fewer considerations of the construction site layout planning that need to be enhanced from construction planning perspective. Moreover, existing assembly work research mostly targets tower or multicomplex projects without extensive considerations of multiple precast low-rise buildings, which ask different strategies to reconsider possible assembly and site layout solutions. Lastly, the reported research shows a clear gap of interaction between BIM models and peripheral construction equipment like cranes. This shortcoming highlights possible break through to investigate the data level interrelationship of BIM objects of precast components with crane work capacity to create site layout planning, which can be further contributed from construction simulation to validate potential solutions.

3. DfMA-COMPLIANT COMMUNITY SITE LAYOUT PLANNING

Assembly work is a key element in DfMA and directly influences on the site layout planning in construction

projects. Because assembly work has extensive connections with peripheral equipment like cranes and interaction with precast components at an operational level, some major influential factors for the site planning are identified to be project features, erection sequence, crane types and crane lifting capacity.

3.1 Features of precast low-rise building project

Construction site layout planning can be different because of variations of project features. Given a group of precast low-rise buildings in a community construction site, the site layout planning involves both macro project planning for overall project delivery and micro single project management work including time, cost, logistics, operations of assembly, health and safety, etc. (Fig 3).



Fig. 3: Community construction site of precast low-rise buildings

From a macro perspective, the site layout planning needs effective coordination of vertical and horizontal transportation so that resources like operators, materials, equipment etc. can be reached and relocated to required places. From a micro perspective, each individual project needs multiple cranes' working positions to satisfy its transportation needs in the assembly work across the whole community site. These macro and micro project features motivate the site layout planning strategies to consider suitable cranes for dynamic precast components' assembly, static components' layout arrangement for each project, their interaction following defined erection sequence for assembly work and its synthesis to be the overall project planning. In order to achieve this effect, the crane assembly simulation can be combined with 4D modelling to verify the whole project process and as result to gain the site layout planning.

3.2 Erection sequence in 4D modelling

Assembly building projects normally ask for predefined precast component lifting orders as erection sequence. Simultaneously, this component assembly sequence also decides every component production order in plants. In terms of 4D modelling, erection sequence is related to the product break structure (PBS) in projects that can contribute to dynamic 4D modeling creation if the PBS is in connection with the work breakdown structure (WBS) of crane lifting task. Therefore, an erection sequence definition can be helpful to generate a construction plan following the identified PBS-creates-WBS (namely PBS→WBS) approach (Zhou et al., 2009). The iCrane search (Kang et al, 2006) also gained insights into this possibility in its development attempts. This planning approach

has great potentials to be integrated with BIM object data and thus be associated with site layout planning to decide precast components' locations. In order to complete such lifting work in a defined sequence, selecting suitable cranes is critical to ensure the assembly process to follow an effective and efficient workflow.

3.3 Cranes in construction

There are seven types of often used cranes in construction projects (Cranenetworknews.com, 2020). Excepting the loader crane is used for loading goods purposes, the rest of six cranes can be classified into location-fixed and location-flexible clusters. Their features are discussed in Table 1.

Table 1: Crane types in the construction industry.

Cluster	Type	General features
Location-flexible	Telescopic Crane	Has a boom with a number of tubes to fit inside each other. Hydraulic mechanisms extend or retract the tubes to length or shorten the boom.
	Mobile Crane	Can be driven to specified locations for lifting work;
	Truck Mounted Crane	Be mounted on a rubber tire truck and provides mobility.
	Rough Terrain Crane	Outriggers can extend vertically or horizontally and are used to stabilize and level the crane when it is hoisting a load of materials.
Location-fixed	Tower Crane	Be fixed on the ground and gives the best of height and lifting capabilities for constructing tall buildings.
	Overhead Crane	Be used in a factory and the hoist of the crane is set on a trolley that will move in one direction along beams. Can move at angles to the direction along the elevated or ground level tracks. The tracks are usually mounted along the side of an assembly area.

The tower crane and the mobile crane are most commonly used cranes on construction sites in the outdoor situation. The former is location-fixed and be suitable for high-rise building construction projects for vertical transporting. The latter however is location-flexible in a horizontal direction that can move to certain positions on the construction site with vertical lifting constraints. Therefore, the mobile crane is the applicable type for the community low-rise assembly buildings. Specific assembly work ought to fit selected crane lifting capacities and potential solutions need to provide convenience to help users to select suitable crane types. This requirement indicates that a full parametric definition mechanism will be valuable to represent potential cranes to be tested for site applicability in a virtual environment so that to choose optimal cranes or their combinations.

3.4 Mobile crane lifting capacity

The mobile crane lifting capacity is associated with both length and angle of boom extension that constitutes its working space. According to the technical data sheet from the Titan Cranes (2019), the longer the boom extension is in a fixed angle, the bigger the covered working radius is with decreased load capacity and vice versa. Along with the boom angle increasing, the lifting capacity in a fixed boom length is directly proportional for heavier loads but with decreased working radius. Because the correlated influences between crane boom extension length and angle, the selection of right mobile cranes is important to decide its spatial working capacity. Therefore, this crane work capacity is decided by the crane lifting position, lorry parking location and boom extension range with length and angle. Such a mobile crane lifting capacity had been discussed and implemented in early research (e.g. Zhang et al, 2012). Its further consideration can extend to interaction with spatial BIM objects of precast components in order to examine not only their spatial features for clash detection in the working space but also physical features like loads weight within certain working ranges. This will help to create smarter crane working conditions to gain potential components' locations on sites.

4. CASE REVIEW

The Trimble Tekla Structures is the BIM authoring software for structure design that provides a set of commercially available assembly utilities as DfMA plug-ins in its design environment. It consists of Crane Console, Tower Crane and Construction Sequencer to allow professionals to perform assembly analysis and simulation using the tower crane (Fig 4). These utilities have the following highlighted features as discussed below.

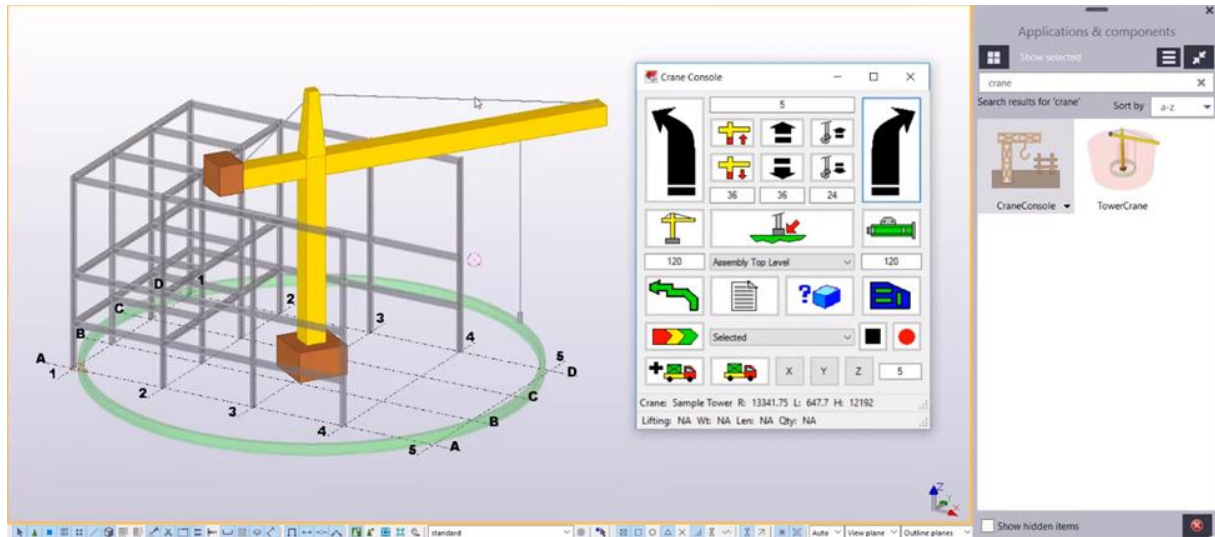


Fig. 4: Tekla crane console for assembly project simulation (Tekla, 2017)

□ **Extensible software architecture:** the utilities are designed as extensible modules so that to be integrated into the design environment with separate installations. This extensibility is flexible for users to choose their preferred modules for use within the same environment and thus own the advantage of seamless data exchange among them and lightweight application.

□ **Parametric crane definition:** the tower crane module generalise a tower crane by using parametric values so as to conveniently define different types. This convenience can keep consistent with physical project requirements to carry out analysis in the virtual environment. Besides this merit, it can also help to check lifting capacity using colour coded graphics for building components' being displayed.

□ **Visualised working range:** the crane console can visualise the tower crane working range as dedicated 3D space dynamically following the tower crane boom motion. It is helpful to identify and judge the suitability of precast component picking points on sites and other associated critical issues.

□ **Erection sequence definition:** the construction sequencer provides built-in spreadsheet features to support users to edit erection sequence, which asks for manual definition like traditional WBS specification in 4D modelling. It can also perform information exchange with external spreadsheets if the sequence is defined outside the design environment;

Besides these advanced features, it has some expectations to deal with community construction site planning discussed as follows.

□ **Mobile crane support:** the mobile crane type is not within the Tekla assembly utility's focus yet that cannot support the mobile crane working analysis. It is therefore confined to deal with related projects.

□ **Crane collaboration:** the current utility only supports individual tower crane lifting simulation for DfMA analysis but not multiple crane's collaboration, which is common in the construction management to have more cranes in a project.

□ **Construction planning context:** the utilities run in the Tekla design environment so that to fully make use of design information. Nevertheless, the whole system is hardly associated with the project management for macro

site layout planning by leveraging crane lifting analysis results because of application context different.

□ **PBS eliciting erection sequence:** the construction sequencer is not benefitted directly from the micro BIM objects of precast components provided in the design environment. Since the manual definition is the only way to establish erection sequence based on human being's subjective judgement, seeking advanced approaches using PBS to automate the erection sequence for site layout planning is necessary.

5. CONCLUSION

Community site layout planning for low-rise precast buildings has a close relationship in both overall construction planning in the macro perspective and individual crane lifting work interacting with precast components at a micro perspective. Overcoming such an engineering challenge becomes promising by leveraging smart BIM objects with the mobile crane capacity analysis. Their interaction in a digitised simulation environment is likely to create an innovative solution. Tekla structures crane utilities indicate this possibility and demonstrate appreciated features in applying the tower crane in its BIM design environment. The reviewed features are helpful to highlight strategies for mobile crane solutions by combining the advantages in the tower crane utilities with compensation for the identified expectations.

Given a community development project with multiple low-rise buildings spreading across the whole area, there are three aspects worth further consideration to apply BIM objects into site layout planning. First of all, a parametric mobile crane is important to examine its load requirements within its working space; Secondly, interaction between the crane and BIM objects can help projects generate erection sequence at a micro level and be verified by applying 4D modelling. Once obtaining all the project erection sequences, lastly it needs to synthesise those micro project sequences and layouts into a community site planning by applying macro 4D modelling as integration. A further investigation will be performed to validate the potential solutions in the future.

6. REFERENCES

- AlBahnassi, H., Hammad, A. (2012). Near Real-Time Motion Planning and Simulation of Cranes in Construction: Framework and System Architecture, *Journal of Computing in Civil Engineering*, Vol. 26, No. 1, Pages 54-63, January 1, 2012
- Bolton, A., Enzer, M., Schooling, J. (2018). The Gemini Principles: Guiding values for the national digital twin and information management framework, *Centre for Digital Built Britain and Digital Framework Task Group* (2018), Available online: <https://www.cddb.cam.ac.uk/system/files/documents/TheGeminiPrinciples.pdf>. Accessed 28/06/2020
- Cranenetworknews.com (2020). 7 Types of Cranes Used In Construction Works, Available at: <https://cranenetworknews.com/7-types-of-cranes-used-in-construction-works>. Accessed: 28/06/2020
- Cassano, M., Trani, M.L. (2017). LOD standardization for construction site elements, *Creative Construction Conference 2017, CCC 2017*, 19-22 June 2017, Primosten, Croatia
- Jupp, J. (2017). 4D BIM for Environmental Planning and Management, *International High-Performance Built Environment Conference –A Sustainable Built Environment Conference 2016 Series (SBE16)*, iHBE 2016
- Kang, S., C., Chi, H., L. (2010) A physics-based simulation approach for cooperative erection activities, *Automation in Construction*, Volume 19, Issue 6, October 2010, Pages 750-761
- Kang, S.C., Miranda, E. (2006). Planning and visualization for automated robotic crane erection processes in construction. *Automation in Construction* 15 (2006) 398 – 414
- Li, H., Chan, N., Huang, T., Guo, H., L., (2009). Optimizing construction planning schedules by virtual prototyping enabled resource analysis, *Automation in Construction*, Volume 18, Issue 7 November 2009 Pages 912-918
- Raimondi Cranes (2019). Technical Data Sheet, MRT189, REV. 00.2019. Available online: <https://raimondi.co/wp-content/uploads/2019/03/Raimondi-MRT189-topless-tower-crane.pdf>. Accessed 23/06/2020.

- Schwabe, K., Teizer, J., König, M. (2019). Applying rule-based model-checking to construction site layout planning tasks, *Automation in Construction* 97 (2019) 205–219
- Sulankivi, K., Kiviniemi, M., (2010). 4D-BIM for Construction Safety Planning. *W099-Special Track 18th CIB World Building Congress*.
- Tan, T., Lu, W., Tan, G., Xue, F. (2020). *Journal of Construction Engineering and Management*, 146(8):04020085, August 2020
- Tekla (2017). Crane Console, *Trimble Solutions Corporation*. Available online: <https://www.tekla.com/resources/youtube-tekla-latin-america/crane-console>. Accessed 23/06/2020
- Titan Cranes (2019). Kato SS-500 45 Tonne Rough Terrain Crane. Available online: <http://www.titancranes.co.nz/portals/182/images/catalogs/products/pdf/649.pdf>. Accessed 23/06/2020
- Trani, M.L., Cassano, M., Todaro, D. (2016). Template customization for Construction Site Information Models, *Creative Construction Conference 2016, CCC 2016*, 25-28 June 2016, Budapest, Hungary
- Wu, K., Sotob, B., G., D., Zhang, F. (2020). Spatio-temporal planning for tower cranes in construction projects with simulated annealing, *Automation in Construction*, 111 (2020) 103060
- Zhang, C., Hammad, A. (2012). Improving lifting motion planning and re-planning of cranes with consideration for safety and efficiency, *Advanced Engineering Informatics* 26 (2012) 396–410
- Zhou, W., Heesom, D., Georgakis, P., Nwagboso, C., Feng, A. (2009). An interactive approach to collaborative 4D construction planning *Journal of Information Technology in Construction (ITcon)* Vol. 14, pg. 30-47, Available at <https://www.itcon.org/2009/5>. Accessed 28/06/2020.

Part5. Monitoring & Inspection

INDRONE: VISUALIZING DRONE FLIGHT PATTERNS FOR INDOOR BUILDING INSPECTION TASKS

Ricardo Eiris

Department of Civil and Environmental Engineering, Michigan Technological University, MI, USA

Gilles Albeaino, & Masoud Gheisari

Rinker School of Construction Management, University of Florida, Gainesville, FL, USA

Brett Benda, & Randi Faris

Department of Computer and Information Science and Engineering, University of Florida, Gainesville, FL, USA

ABSTRACT: *The use of drones or unmanned aerial vehicles for indoor building inspection tasks requires users to understand flight patterns (e.g., flight routes, camera focus points, target approach strategies) for maneuvering the aircraft. This study focuses on exploring the visual representation of human behaviors performing indoor building inspection flight operations using drones. An interactive 2D representation of drone flight spatial data – InDrone – was developed to characterize flight patterns during the inspection of indoor markers that were already defined in the inspection area and visualize potential maneuvering difficulties around those markers. This study evaluated InDrone via a user-centered assessment methodology that measured performance and usability ratings. Using visual flight patterns, users identified inspection markers and difficult-to-inspect building areas in 63% (STD = 48%) and 75% (STD = 35%) of the time on average, respectively. Overall, users reported high scores for the usability of InDrone during the flight pattern recognition tasks with a mean score of 77% (STD = 15%). This study contributes to the definition of visual affordances that support the communication of flight patterns for drone indoor building inspection tasks. The InDrone pilot system demonstrates the usefulness of visual affordances to explore drone flight spatial data for indoor building inspections.*

KEYWORDS: *Unmanned Aerial Vehicles (UAVs), Drones, Construction, Flight Visualization, Indoor Building Inspection*

1. INTRODUCTION

Drones or Unmanned aerial vehicles (UAVs) have been increasingly adopted in the architecture, engineering, and construction (AEC) industry for inspecting building structures (Albeaino et al., 2019). Building inspection tasks require operators to maneuver a drone to a location of interest (e.g., a truss joint, a wall crack, a connection pad) and then independently manipulate the camera on the drone to visually inspect the given target. While many of these drone inspection flight operations can be performed autonomously in outdoor environments using GPS signals, similar indoor operations present challenges that limits the use of automated operations. Researchers have attempted to utilize other technologies to enable autonomous flights indoors by leveraging ultra-wideband (UWB) and wireless local area networks (WLAN) (Jang and Skibniewski, 2008), computer vision-based algorithms (Padhy et al., 2018), SLAM navigation (Zahran et al., 2018), and fiducial markers (Nahangi et al., 2018). However, these approaches have been found expensive to implement, difficult to deploy, or overall restrictive due to context dependencies for being applied in real-world construction sites (McCabe et al., 2017; Nahangi et al., 2018). Consequently, drones are still often manually operated in indoor environments for building inspection applications.

Even with manual operations, successful drone flights in GPS-denied environments are difficult to be accomplished and require extensive expertise, skills, and precision from the operators and flight team members to overcome indoor challenges. Examples of indoor navigation challenges that could potentially result in drone accidents include: (1) magnetic interferences caused by the presence of several obstacles; (2) worker's distraction caused by the operation of drones in enclosed areas; as well as (3) high-stress and concentration levels due to the low margin of error allowed by the pilot in indoor environments (Kruijff et al., 2012; McCabe et al., 2017). Extensive training is therefore needed to improve the pilots' navigational capabilities and guide them in their decision making, especially in dynamic environments such as the AEC's. In this context, recognizing the drone inflight barriers encountered during previous human-operated indoor flights and the pilots' associated behaviors is valuable for future pilot training and successful drone deployment in this setting.

Due to the importance of human-based operations in drone control systems, the understanding of bidirectional information and loop mechanisms that drive human-drone flight operations is increasingly necessary. As human operators interact with the drone technologies, the gained spatial information (e.g., position, elevation, facing direction) determines the subsequent operational steps within the flight maneuvers. This human understanding of spatial information requires constant updating based on the interaction cycle. Such human-drone interactive systems are currently investigated to improve collision avoidance algorithms (Maxey and Shamwell, 2019) and operator training strategies (Zhou et al., 2019).

This exploratory study concentrates on investigating one aspect of these human-drone interactions – human interpretation of drone spatial information to determine the operational requirements in building inspection tasks. Specifically, the understanding of human-drone interactions in the AEC domain is investigated in two ways: (1) definition of visual affordances that communicate drone building inspection tasks; and (2) development of a system that enables visual exploration of drone spatial data.

2. BACKGROUND

Current literature on interpretable visualizations for flight spatial data of manned and unmanned aircrafts employs 3D and 2D approaches. The adoption of 3D representations to represent inherently spatial data is widely employed in the existing visualization methods (Dübel et al., 2014; Zhong et al., 2012). For instance, Chen et al. (2018) proposed the use of 3D models for drone flight path planning to capture location images. The authors demonstrated how to utilize 3D models to illustrate drone flying paths, showing the height and distance of the drone path with respect to the object being captured. It was found that with the addition of depth and camera direction to markers in the visualization, users were able to understand the spatiotemporal relationships between the drone and the environment for capturing images of complex objects. In another example, Li et al. (2018) employed a 3D visual comparison on various indoor flight paths obtained from the models to illustrate collision avoidance algorithms. The paper utilized different line continuity and colors, enabling the observer to locate the distinct paths rapidly in the 3D space. Additionally, the use of occlusion within the visualization offers the observer a sense of the locations where their vision might become obstructed by objects during that flight path.

Although 3D proposes an intuitive approach to represent real-world spatial data, challenges occur with respect to the ability of users to interpret information within these visualizations. First, distortions occur due to the view perspective of the user. This causes difficulties for the user to accurately understand relative positions, size of objects, and distribution of graphical elements (Zhong et al., 2012). Additionally, occlusion during the visualization introduces difficulties in the perception of the spatial location of objects, affecting the readability and measurability of object attributes (Zhong et al., 2012). This effect is especially pronounced within indoor environments where the spatial distribution of buildings might introduce many fixed occluding elements (e.g., walls, staircases, installed equipment). Ultimately, the combination of these two challenges requires the introduction of complex interactions to navigate the data. The addition of another layer of complexity to the visualization challenges requires that the user must not only concentrate on observing the data for meaning but must also concentrate on manipulating the view perspectives to obtain the appropriate information.

In response to the challenges associated with representing flight spatial data in 3D, previous studies have explored 2D approaches to reduce complexity and display only key desired information that is useful for the target domain users. For example, Kang et al. (2018) proposed a method to simplify drone navigation and image capture by providing a novel user input modality on mobile devices. The authors demonstrate how to visually indicate drone trajectory and image capture direction simultaneously using a 2D projection of the drone path. Information is shown at certain time intervals, indicating front-facing direction of the camera, and illustrating the locations where the user spent the most time for capturing environment. The results from usability experiments showed that the filmmaking target users found the proposed approach intuitive to use and easier than traditional navigation methods (e.g., controller). In another example, Andrienko et al. (2019) evaluated the amount of information presented in 2D to manned aircraft pilots, reducing clutter by grouping flight data on a per-pilot and per-flight phase (take-off, cruise, landing) basis. The authors used these grouping techniques to determine how outside forces (e.g., air traffic control) influenced flight paths inequitably. Expert pilots indicated that the developed system was capable of diagnosing patterns of flight behavior as well as providing insight into the outside factors that influenced such behavior. Although existing visualization methodologies in the literature have explored some of the aspects required to

understand drone flight paths, none of the studies have specifically investigated these applications within the AEC domain in general and building inspection tasks more particularly.

3. METHODOLOGY

To explore human interpretable drone spatial information representations, data was collected from four commercially certified drone pilots within a virtual reality (VR) simulation to create a visualization of building inspection operations. Using the experts' data, this investigation explored the visual design elements necessary to demonstrate human behaviors during building inspection tasks in terms of approaches to view the inspection targets and detection of areas with potential difficulty. The created InDrone platform leverages a 2D interactive visual representation of spatial data to provide users a method to identify flight patterns, facilitating the recognition of appropriate practices within the inspection tasks. To evaluate the produced design, a user-centered study was performed to assess the task performance of information identification as well as the usability of the system. Interviews with expert pilots were conducted to define a set of tasks and evaluate the proposed design, employing a think-aloud methodology and a post-assessment survey. Detail explanation of each of platform design rationale are provided in the following subsections.

3.1 InDrone Platform

The goal of this paper's visualization is to convey the operational steps from expert drone pilots during the performance of an indoor building inspection. These operational steps can be visualized through flight behaviors using elements such as path patterns, drone direction, and target approach strategies. Data was collected from four commercially certified drone pilots to understand these operational steps for building inspection tasks. These expert pilots were asked to perform a drone flight inspection of the Perry Yard in the Rinker Hall building at the University of Florida campus within a VR simulation. The VR environment used an Oculus Rift head-mounted display and an Xbox game controller to operate the drone (Figure 1). The Perry Yard simulation was created within the Unity Game Engine, employing a point cloud obtained from the FARO Focus 3D S 120 laser scanner. The expert pilots were tasked with examining 10 target markers placed in strategic locations on the point cloud of the building. Spatial flight data was logged by the simulation in 1/5 second intervals. For each flight, the following data was captured: 3D (x, y, z) coordinates of the drone, rotation of the drone with respect to its center of mass (pitch, roll, yaw), drone speed (x, y, z) and a timestamp. Each of the four pilots ran through the simulation twice for a total of 8 flight paths stored in 8 separate data logs. For the purposes of this research, the logs were converted to JSON format. A series of 2D web-based implementations were produced utilizing JavaScript and D3 Version 5 (Bostock et al., 2011).



Fig. 1: Virtual Reality Data Collection from Expert Pilots (Real -left- site duplicated as a Virtual -right- site).

3.1.1 InDrone Platform Goals

The goals for the InDrone visualization platform in this study were established by iteratively exploring the collected data and interviewing commercially certified drone pilots. Initially, the data from the VR flights was explored by implementing a preliminary representation of the drone spatial data. In the existing literature, 2D and 3D approaches have been considered to represent spatial data similar to the data collected from the expert users' drone flights. This

first implementation focused on displaying the spatial distribution of the drones across the inspection space. For this study, a 2D representation was selected due to the advantages of allowing the viewer to see the entire flight paths at once. In a 3D visualization, some of the paths would be occluded by parts of the building which would have resulted in the exploration of interactivity methods to reduce spatial complexity. Additionally, within the AEC domain, users are accustomed to analyzed information utilizing isometric projections of 3D real-world objects. By maintaining 2D visualization, the perception expectations of domain professionals allow the proposed design to provide simple-to-interpret representations of building inspection tasks and locations.

Following, a set of semi-structured interviews were conducted with the same four expert pilots that previously participated in the VR simulation. The expert pilots observed the preliminary 2D representation of all the collected spatial data. During the interviews, information was collected regarding pattern recognition within the data and determination of flight strategies from the visual representation. From the analysis of the interviews, two main themes were identified in terms of pilot drone flight behaviors: (1) approaches to view the inspection markers; and (2) difficult areas that require longer times to maneuver. These two themes translated into the design goals of this project as:

G1 – Demonstration of the pilots’ approaches to view the inspections markers. The visual representation of these approaches should reflect the drone spatial positions across time and drone orientation with respect to the marker locations.

G2 – Detection of areas in the flight path where it was difficult to observe inspection markers. The visual representation should reveal the inspection markers that require a longer time to be explored while performing the drone flight building inspection.

3.1.2 Visualizing Drone Critical Operations During Inspection Tasks

To accomplish the InDrone platform goals of this investigation, data was encoded following Cleveland and McGill (Cleveland and McGill, 1986) principles for visual design. In this study’s platform design, the relationship between the inspection location and the spatial data is critical for the understanding of the drone operations. A Cartesian plane with real-world dimensions in meters hosted a background contour image of the building’s point map to demonstrate the context of the flight operations (Figure 2).

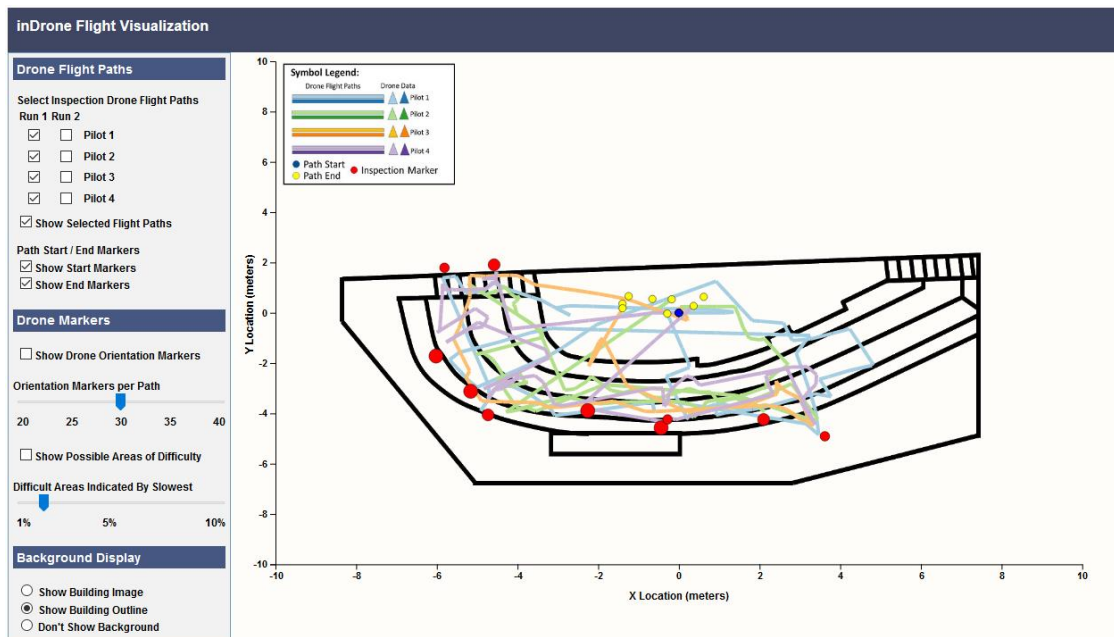


Fig. 2: Multiple Drone Flight Paths Visualization

Within that background, the important spatial data was encoded in the visualization using inspection markers, flight paths, and drone orientations. These encodings corresponded with **G1** by enabling users to determine the pilot's approaches to perform the flight tasks (Figure 3). In the visualization, the inspection markers were represented by bright red markers. These target inspection markers corresponded with spatial coordinates in the simulated flight operation. Pre-attentive processing enabled users to quickly recognize the targets in the spatial configurations of the projected building. For each pilot, flight paths were plotted using the x and z spatial coordinates—y coordinates were encoded separately as altitude. Each pilot's flight path was encoded with a unique color, with the second run varying in shades of the same color. This allowed the users to associate position with each pilot's paths displayed in the inspection location. Because the flight paths varied in length and contained a lot of overlapping points (the drone may not be moving every 1/5 of a second), the data was resampled using the initial steps of the \$1 algorithm (Wobbrock et al., 2007), reducing the number of points per line while maintaining the overall length of the path. Additionally, the start (blue) and end (yellow) points were explicitly shown to indicate the direction of the flight path. Moreover, the drone's yaw was represented by triangular markers that scaled according to the y coordinate altitudes along the drone path (larger triangles being at higher altitudes and smaller triangles lower altitudes). These triangular markers were additionally encoded using the yaw rotation angle of the triangle to demonstrate the forward point direction at a given time. The triangular marker encoding in conjunction with the x, y, and z coordinates, represents the drone fly path in a way that keeps unmanned vehicle parallel to the ground. Finally, a slider was provided to the user to increase the granularity of triangles displayed to account for the potential loss of information introduced by the resampling method applied to the data.

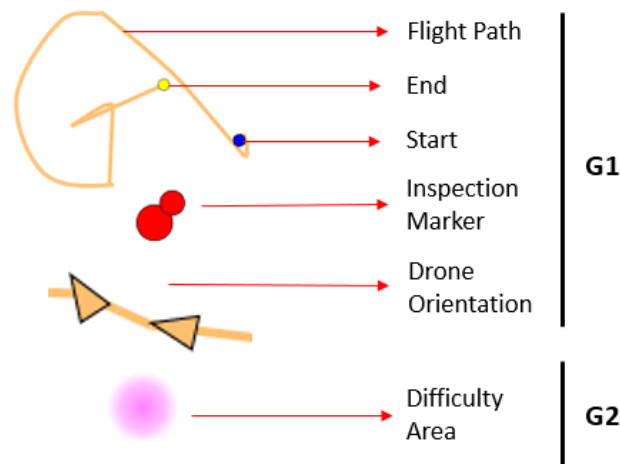


Fig. 3: Visual encodings to accomplish platform goals

To demonstrate the areas of difficulty as described in **G2**, fuchsia circles were used to represent locations with low drone speed (Figure 3). During the inspection task, areas of low speed indicate that the pilot requires maneuvering with exceptional care. The speed data for each drone pilot was ranked from low to high, and the top 2% of low speeds were employed to demonstrate the difficulty areas. A slider was provided to change this threshold varying from 1% to 10%. It is important to highlight that the fuchsia circles were partially transparent, enabling the user to observe color intensity variations on areas with dense overlaps.

With the objective of supporting all the encodings and the user navigation of the spatial data, an interface was created following Shneiderman's mantra (Shneiderman, 1996) for information seeking. Iterative development was utilized to refine these interactions. A pilot test was performed with two users to understand the usefulness of the proposed encodings and interactions for the visualization. Improvements were done considering their feedback, and the challenges faced during the interaction with the system. The resulting implementation from the iteration is shown as Figure 2. Initially, an overview of the data was provided by enabling the user to observe the start/end points for the first drone flight of each pilot. To provide a zoom and filter of the data, a *Drone Flight Path* menu section was provided to enable users to toggle on/off different paths using a check box interface. Using the *Drone Markers* menu section, users were able to activate or deactivate the triangles that denoted orientation of the drone within the paths. Similarly, a *Difficult Areas* checkbox allowed users to display the fuchsia circles that denote reduced speed areas. The *Background Display* menu permitted users to modify the background using radial buttons.

Details-on-demand could be obtained from any of the markers (inspection, start, end, triangles) by hovering over them to reveal a tooltip with the raw data. Finally, the control of the parameters aligned with **G1** and **G2** was exposed to the users to provide them with further details that they might require.

3.2 EXPERIMENTAL EVALUATION

This project utilized a user-centered experimental evaluation to assess two different metrics: task performance and usability rating. First, task performance focused on studying how users retrieve important information from the visualization in terms of **G1 – Approaches** (pilots’ approaches to view the inspections markers) and **G2 – Difficulties** (difficulties detection around inspection markers). This measurement is intended to identify the advantages and challenges of the proposed design for the users to understand drone operations during inspection tasks. A set of 10 questions was developed to assess user task performance using high- and low-level cognition analysis, as displayed in Table 1. For the **G1 – Approaches**, four questions aimed to determine how users perceived the drone navigation patterns in the inspection location as well as pilots’ behaviors while exploring the target markers (high-level cognition). For the **G2 – Difficulties**, two questions aimed to establish how users determined challenges to observe target markers by the drone pilots (high-level cognition). Finally, four questions were asked about usability to provide a practical understanding of how users employed different encodings to explore the visualization (low-level cognition).

Second, the System Usability Scale (SUS) survey (Brooke, 1996) was used to assess the usability rating assigned to the visualization. This survey provided a metric for the visualization in terms of ease of use, satisfaction, effectiveness, and design efficiency (Brooke, 2013). The survey used a 5-point Likert scale that contained ten questions scaled from strongly disagree to strongly agree. The usability score was computed by inverting the score of negative statement questions, summing all the scores, multiplying the resulting score by 2.5, and normalizing the scores (ranging from 0 to 100) as established by Brooke (1996). SUS usability benchmarks have shown that the average score of a system approximates 68% in the scale (Sauro, 2011). To further support the user responses in this survey, an open-ended comment section was provided.

Table 1: Task Performance Question

Approaches – G1	Difficulties – G2	Usability
<i>1.</i> Which drone pilot performed the building inspection task the fastest?	<i>1.</i> Which building inspection target was the most difficult to observe across all drone pilots?	<i>1.</i> How many drone pilots are present in the data showed to you?
<i>2.</i> Do drone pilots have a preference target exploration direction (i.e., clockwise, counterclockwise)	<i>2.</i> Which building inspection target was the easiest to observe across all drone pilots?	<i>2.</i> How many flights per pilot are shown in the visualization?
<i>3.</i> Does the drone camera for Pilot 2 face every target at some point in the flight path?		<i>3.</i> What general area do drone pilots start and end their flights?
<i>4.</i> Did any of the drone pilots inspect a target more than once?		<i>4.</i> What is the elevation of the highest building inspection target?

Participants were recruited from the University of Florida. The participants interacted with the visualization while a researcher asked the questions defined in this document. A think-aloud protocol was employed to obtain as much qualitative data as possible from the users’ interactions during the task performance activities. These conversations were recorded for later analysis. After completing the task performance questions, the SUS survey instrument was administered to the participants using an online Qualtrics questionnaire (Qualtrics, 2019). Posteriorly, the responses from the task performance questions were graded to determine the number of successfully or unsuccessfully answered questions. Furthermore, the SUS survey instrument was scored using the analysis previously described. Prior to the task performance and usability data collection, users completed a consent form (IRB201902372) and a demographics survey describing their age, gender, education, and experiences with drones and building inspection tasks.

4. RESULTS AND DISCUSSION

A total of 10 participants evaluated the proposed design. Participants had an average age of 28 years (STD = 5 years) and were mostly males (90%). A large proportion of the participants were PhD students (60%), but the sample also contained master's (20%) and undergraduate (20%) students. None of the participants reported to have a commercial license to fly drones but presented varying degrees of familiarity with drone technologies (Low = 30%; Average = 70%; High = 0%) and building inspection tasks (Low = 40%; Average = 60%; High = 0%). While none of the participants were certified drone pilots, the goal of the InDrone platform is to enable future pilots learn flight strategies; thus, these participants were deemed to be suitable for the analysis of the InDrone platform. Participants completed the task performance and usability questions in approximately 14 minutes (Average = 14 minutes, STD = 4 minutes).

The results of the task performance questions were analyzed using descriptive statistics as shown in Table 2. The average score for the **G1 – Approaches** was 63% (STD = 48%). This score indicates that participants had challenges understanding some of the critical operations during inspection tasks. While questions 1 and 2 were easily answered by the participants, questions 3 and 4 were very difficult. On average, participants scored 100% for questions 1 and 2 but had an average success rate of 50% for question 3 and 0% for question 4. Participants were unable to properly identify the drone facing direction across time due to potential issues with clutter, height identification, and temporal relationships in visualization. For instance, one of the participants indicated that *“the triangles overlap in this marker, but I’m not sure if that means that the pilot is looking at the target just once or multiple times”*.

The average score for **G2 – Difficulties** was 75% (STD = 35%). This score indicates that most participants were able to detect difficult-to-maneuver areas in the inspection locations. While question 1 had a 100% success rate, question 2 had a success rate of 50%. The lower average success rate of question 2 was potentially caused by the lack of identifiers of high-speed areas. In the visualization, only low-speed areas were highlighted, and it was assumed that the target markers with a lesser number of fuchsia circles implied lower difficulty. Finally, the average score for usability questions was 95% (STD = 6%). These consistently high scores indicate that the visualization was easy to navigate for low-level type of cognitive tasks such as the ones asked in this category.

Table 2: Task Performance Descriptive Statistics

Task Performance		Approaches	Difficulties	Usability
	Average	63%	75%	95%
STD	48%	35%	6%	

The results of SUS survey were analyzed using the strategy outlined in Brooke (1996) and descriptive statistics were reported as shown in Table 3. For the SUS scores, the average score was 77% (STD = 15%). This average score in this investigation is above the 68% average that was found in a meta-analysis for usability studies (Sauro, 2011). This result indicates that the system design in this research presents a good usability rating as reported by participants. Moreover, these results are consistent with the scores reported for the task performance questions. Participants’ comments in general were positive about the usability of the system. One participant indicated that *“[the] system was not too complicated overall after using it for a couple of tasks”* and another one suggested that *“the system can easily provide a lot of information about the paths of the pilots”*.

Table 3: SUS Descriptive Statistics

SUS (Brooke, 1996)	Average	STD	Max	Min
	77%	15%	98%	55%

Overall, the observed results for the designed affordances within InDrone platform indicate that trainees were able to successfully identify drone inspection speed and flight path direction. Additionally, trainees were able to identify the level of difficulty required to inspect certain markers within the location. The high usability findings further support the use of these visually encoded affordances for drone inspection tasks. Ultimately, the findings of this study provide insights for designers and practitioners of indoor drone data visualization platforms in terms of effective visual encodings that demonstrate human behaviors.

5. LIMITATIONS

This study exhibited limitations in two main areas: (1) sample size; and (2) data representation. First, due to the exploratory nature of the research, the sample size of the collected data was small. This eliminates the possibility to provide statistical generalizations over the whole study population in terms of **G1** and **G2**. However, this sample size seems appropriate for usability studies, as research has revealed that 10 participants can identify up to 95% of the problems in software tools (Faulkner, 2003). Second, the 2D representation selected for this study limits the data representation flexibility. Some of the height encodings that are inherently 3D are difficult for users to understand and interpret in a 2D representation. However, constraining the visualization to 2D simplifies interaction and reduces the requirement for larger exploration times often required in 3D representations.

6. CONCLUSION AND FUTURE WORK

This exploratory research investigated the design requirements and considerations necessary to understand drone pilots' behaviors while performing building inspection tasks. Design goals were established through iterative exploration of drone spatial data and interviews with commercially certified drone pilots. As a result, the two defined goals for this study were: **G1** – identify pilots' approaches to view the inspections markers and **G2** – demonstrate difficulty detection around inspection markers. A user-centered experimental evaluation was performed to assess the users' task performance and usability rating while utilizing a developed visualization system. Results showed that users identified pilots' approaches to view the inspections markers on average 63% (STD = 48%) of the time. This was caused by challenges with clutter, height identification, and temporal relationships. On the other hand, it was found that on average, most users were able to identify difficult-to-inspect building areas with a success rate of 75% (STD = 35%). Finally, users reported high scores for usability of the system during both, task performance activities and the SUS survey. The survey average score was 77% (STD = 15%), indicating a good usability rating.

Future work in this research area should explore summarization of flight paths to represent commonalities across multiple drone pilots. By condensing common paths into a single representation, visualization clutter can be reduced, which could avoid some of the challenges reported in this research. Moreover, an in-depth evaluation of the accurate perception of the height encoding needs to be performed to better understand the impact relative sizes have on the users' responses. Comparative analyses should also be conducted between the 2D visualization design proposed in this study and a 3D design to assess the advantages and disadvantages of each approach for drone building inspection applications. While this study focuses on the development of a UAV-mediated data visualization platform – InDrone, additional investigations are warranted to validate the effectiveness of this design in reducing the pilots' stress and concentration levels, as well as improving their navigational skills and decision-making to successfully accomplish indoor building inspection tasks.

7. REFERENCES

- Albeaino, G., Gheisari, M. and Franz, B.W. (2019), "A systematic review of unmanned aerial vehicle application areas and technologies in the AEC domain", *Journal of Information Technology in Construction (ITcon)*, Vol. 24, pp. 381–405.
- Andrienko, N., Andrienko, G., Garcia, J.M.C. and Scarlatti, D. (2019), "Analysis of Flight Variability: a Systematic Approach", *IEEE Transactions on Visualization and Computer Graphics*, presented at the IEEE Transactions on Visualization and Computer Graphics, Vol. 25 No. 1, pp. 54–64.
- Bostock, M., Ogievetsky, V. and Heer, J. (2011), "D³ Data-Driven Documents", *IEEE Transactions on Visualization and Computer Graphics*, presented at the IEEE Transactions on Visualization and Computer Graphics, Vol. 17 No. 12, pp. 2301–2309.
- Brooke, J. (1996), "SUS-A quick and dirty usability scale", *Usability Evaluation in Industry*, London–, Vol. 189 No. 194, pp. 4–7.

- Brooke, J. (2013), “SUS: a retrospective”, *Journal of Usability Studies*, Usability Professionals’ Association Bloomingdale, IL, Vol. 8 No. 2, pp. 29–40.
- Chen, Y.-A., Wu, T.-Y., Chang, T., Liu, J.Y., Hsieh, Y.-C., Hsu, L.Y., Hsu, M.-W., et al. (2018), “ARPilot: designing and investigating AR shooting interfaces on mobile devices for drone videography”, *Proceedings of the 20th International Conference on Human-Computer Interaction with Mobile Devices and Services*, Association for Computing Machinery, Barcelona, Spain, pp. 1–8.
- Cleveland, W.S. and McGill, R. (1986), “An experiment in graphical perception”, *International Journal of Man-Machine Studies*, Vol. 25 No. 5, pp. 491–500.
- Dübel, S., Röhligh, M., Schumann, H. and Trapp, M. (2014), “2D and 3D presentation of spatial data: A systematic review”, *2014 IEEE VIS International Workshop on 3DVis (3DVis)*, presented at the 2014 IEEE VIS International Workshop on 3DVis (3DVis), pp. 11–18.
- Faulkner, L. (2003), “Beyond the five-user assumption: Benefits of increased sample sizes in usability testing”, *Behavior Research Methods, Instruments, & Computers*, Vol. 35 No. 3, pp. 379–383.
- Jang, W.-S. and Skibniewski, M.J. (2008), “A wireless network system for automated tracking of construction materials on project sites”, *Journal of Civil Engineering and Management*, Vol. 14 No. 1, pp. 11–19.
- Kang, H., Li, H., Zhang, J., Lu, X. and Benes, B. (2018), “FlyCam: Multitouch Gesture Controlled Drone Gimbal Photography”, *IEEE Robotics and Automation Letters*, presented at the IEEE Robotics and Automation Letters, Vol. 3 No. 4, pp. 3717–3724.
- Kruijff, G.-J.M., Pirri, F., Gianni, M., Papadakis, P., Pizzoli, M., Sinha, A., Tretyakov, V., et al. (2012), “Rescue robots at earthquake-hit Mirandola, Italy: A field report”, *2012 IEEE International Symposium on Safety, Security, and Rescue Robotics (SSRR)*, IEEE, pp. 1–8.
- Li, F., Zlatanova, S., Koopman, M., Bai, X. and Diakité, A. (2018), “Universal path planning for an indoor drone”, *Automation in Construction*, Vol. 95, pp. 275–283.
- Maxey, C.J. and Shamwell, E.J. (2019), “Navigation and collision avoidance with human augmented supervisory training and fine tuning via reinforcement learning”, *Micro- and Nanotechnology Sensors, Systems, and Applications XI*, Vol. 10982, presented at the Micro- and Nanotechnology Sensors, Systems, and Applications XI, International Society for Optics and Photonics, p. 1098228.
- McCabe, B.Y., Hamledari, H., Shahi, A., Zangeneh, P. and Azar, E.R. (2017), “Roles, Benefits, and Challenges of Using UAVs for Indoor Smart Construction Applications”, *Computing in Civil Engineering 2017*, pp. 349–357.
- Nahangi, M., Heins, A., McCabe, B. and Schoellig, A. (2018), “Automated Localization of UAVs in GPS-Denied Indoor Construction Environments Using Fiducial Markers”, *ISARC. Proceedings of the International Symposium on Automation and Robotics in Construction; Waterloo*, Vol. 35, IAARC Publications, Waterloo, Canada, Waterloo, pp. 1–7.
- Padhy, R.P., Verma, S., Ahmad, S., Choudhury, S.K. and Sa, P.K. (2018), “Deep Neural Network for Autonomous UAV Navigation in Indoor Corridor Environments”, *Procedia Computer Science*, Vol. 133, pp. 643–650.
- Qualtrics. (2019), *Qualtrics*, Provo, Utah, USA.
- Sauro, J. (2011), “MeasuringU: Measuring Usability with the System Usability Scale (SUS)”, available at: <https://measuringu.com/sus/> (accessed 9 June 2020).

- Shneiderman, B. (1996), “The eyes have it: a task by data type taxonomy for information visualizations”, *Proceedings 1996 IEEE Symposium on Visual Languages*, presented at the Proceedings 1996 IEEE Symposium on Visual Languages, pp. 336–343.
- Wobbrock, J.O., Wilson, A.D. and Li, Y. (2007), “Gestures without libraries, toolkits or training: a \$1 recognizer for user interface prototypes”, *Proceedings of the 20th Annual ACM Symposium on User Interface Software and Technology*, Association for Computing Machinery, Newport, Rhode Island, USA, pp. 159–168.
- Zahran, S., Moussa, A., Sesay, A. and El-Sheimy, N. (2018), “Enhancement Of Real-Time Scan Matching For Uav Indoor Navigation Using Vehicle Model”, *ISPRS Annals of Photogrammetry, Remote Sensing and Spatial Information Sciences*, Vol. IV–1, pp. 171–178.
- Zhong, C., Wang, T., Zeng, W. and Müller Arisona, S. (2012), “Spatiotemporal Visualisation: A Survey and Outlook”, *Digital Urban Modeling and Simulation*, Springer Berlin Heidelberg, Berlin, Heidelberg, pp. 299–317.
- Zhou, J., Zhu, H., Kim, M. and Cummings, M.L. (2019), “The Impact of Different Levels of Autonomy and Training on Operators’ Drone Control Strategies”, *ACM Transactions on Human-Robot Interaction*, Vol. 8 No. 4, p. 22:1–22:15.

VISUAL DUST EMISSION MONITORING FOR CONSTRUCTION ACTIVITIES

Ruoxin Xiong & Pingbo Tang
Carnegie Mellon University, United States

ABSTRACT: Automatic dust emission records and relevant activity monitoring will provide spatiotemporal details of a construction site for identifying principles of predicting and controlling dust. This paper examines an image-based dust emission monitoring method for construction activities. Considering the significant variations in the concentration, shapes, and colors of dusty areas, individual features could barely achieve reliable dust recognition under different conditions. Collecting a large-scale dust dataset also requires manual identification of sparse dust emission events from dense images or video data, which can be costly, tedious, and error-prone. However, current state-of-the-art classification models, particularly deep neural networks (CNN), are typically data-hungry. To address these challenges, the authors integrate multiple features, including histograms of oriented gradients (HOG), dark channels, and CNN features, to harvest dynamic dust cues inherent in the image. The ensemble support vector machine (E-SVM) then recognizes dust emission events based on a multi-feature weighted voting mechanism. To facilitate the study, this work establishes a Construction Dust Emission (CDE) dataset covering various construction activities and dust levels. The experimental results show that the proposed E-SVM method with multi-feature fusion provides higher accuracy than individual SVMs with a single feature. This approach also outperforms state-of-the-art classifiers and deep-learning methods.

KEYWORDS: Construction dust emissions; Multi-feature fusion; Convolutional neural network (CNN); Histograms of oriented gradients (HOG); Dark channel; Ensemble support vector machine (E-SVM)

1. INTRODUCTION

Construction sites contribute to a significant dust pollution source to the air quality of surrounding areas (Zuo *et al.*, 2017). Large amounts of dust emissions can occur alongside routine construction jobs, including concrete production, drilling and grinding, bulk material storage, ground excavation, and cutting operations. Fugitive dust can also pose substantial health risks to construction workers. Inhaling excessive respirable dust particles frequently results in serious diseases, such as lung cancer, silicosis, chronic obstructive pulmonary disease, and occupational asthma (Wu *et al.*, 2016). Every year in the UK, over 500 construction workers die from lung cancer caused by silica dust (IOSH, 2014). The hazardous effects of the construction dust call for proactive dust control to minimize the associated risks.

Construction site emissions are typically uncertain across large spatial and temporal scales. Activities and stages have different emission characteristics, varying on the employed materials, machines, and plants, as well as work locations (Xing *et al.*, 2018). The amount of dust impacts is also strongly correlated with the duration and frequency of work activities. Automatically documenting dust emission events together with site layouts and construction activities will help uncover dust pollution laws pertaining to dust generation, spreading, and how to leverage those laws to forecast and control dust based on historical data analytics. For this purpose, designing an effective dust recognition method is essential to characterize spatiotemporal details of dust pollution at certain construction stages or construction activities.



Fig. 1: Positions of dust analyzers. Left: demolition activity. Middle: earthwork. Right: site entrance. Pictures from HSE (HSE, 2011).

To determine dust concentrations for each identified dusty work process, inspectors will visually assess dust deposition events in the vicinity of the site boundary (IAQM, 2018). Despite their simple implementations,

on-site observations are time-consuming, subjective, and error-prone. In recent years, many construction companies have applied a wide variety of sophisticated sensors to provide high-resolution measurements of fugitive dust emissions. These sophisticated analyzers report dust emission data based on dust sampling near the locations where the construction activities occur, as shown in Fig. 1. However, their effectiveness is limited in large covered workplaces due to high setup costs and stringent operating requirements. Moreover, the provision of passive dust measurements makes it challenging to differentiate construction dust sources from background pollution (e.g., traffic and industrial emissions).

With the increasing availability of on-site cameras, it is prevalent to perform image-based condition assessments cost-effectively and efficiently (Kim *et al.*, 2019). Visible dust plumes are also evidence of dust emissions. This context inspires us to leverage an abundance of visual information for dust monitoring in large and open workplaces. However, unlike rigid construction objects with distinctive properties, characterizing dust features is challenging because dust is of significant variation in shape and color. Meanwhile, dusty spaces may blend with background regions if the dust concentration is too low. Using a single type of feature can hardly retrieve stable and efficient information under different conditions. Moreover, collecting a large-scale dataset of real-world dust emissions demands manually identifying uncommon events from dense video or image data, which can be costly, tedious, and error-prone. Data scarcity requires the designed algorithm to attain high accuracy within a small training dataset. Recent state-of-the-art image classification models, such as deep neural networks, are typically data-hungry. Training these networks with insufficient data may lead to overfitting and reduced accuracy.

This work addresses these limitations in two aspects. First, the authors utilize multiple types of features, including convolutional neural network (CNN) features and hand-crafted features, to harvest subtle dust cues inherent in the image. Second, an ensemble support vector machine (E-SVM) classifier combines a set of individual classifiers into a more robust decision process. The ensemble strategy has less dependence on a single decision while retaining redundant components, which can overcome the deficiency of data samples for model training. Overall, this paper presents a new dust detection approach that offers the following contributions:

- (1) To the best of our knowledge, the presented approach makes the first attempt to propose an image-based dust emission monitoring method for construction activities in large and open workplaces. This attempt involves extensive experiments to verify the new method's potential for measuring dust emissions despite utilizing a small number of data samples.
- (2) The new approach incorporates different types of image features through many experimental analyses. All selected features work collaboratively within a voting weight-based E-SVM classifier. This strategy demonstrates its superior performance through quantitative comparisons with state-of-the-art classification methods.
- (3) This work has created the first Construction Dust Emission (CDE) dataset containing 500 real dust emission images, covering various construction site scenarios. The authors hope that the established CDE dataset will stimulate interests and subsequent research studies.

The organization of the rest of the paper is as follows. Section 2 reviews the related work. Section 3 then describes the established CDE dataset and its data distributions. After that, Section 4 presents the E-SVM classification approach, including dust feature extraction and ensemble SVM classifier design. Section 5 discusses the experimental results in the CDE dataset and compares the implemented method with state-of-the-art approaches. Section 6 concludes this paper with some findings and suggestions for future research studies.

2. BACKGROUND & RELATED WORK

Typically, object classes consist of two broad categories: *things* (objects with a well-defined shape) or *stuff* (amorphous background regions) (Caesar *et al.*, 2018). Most of the object recognition efforts in construction domains have focused on recognizing *thing* classes, such as workers and equipment. Appropriate feature selection and extraction is the first and core part of the object recognition task. Traditional algorithms depend on manual selection of related features and machine learning classification. For instance, Park and Brilakis (2012) utilized the histogram of oriented gradients (HOG) to characterize construction workers in the video frames. Likewise, Memarzadeh *et al.* (2013) applied HOG and Colors descriptors and used an SVM classifier to enable automated detection of construction equipment (e.g., excavators and dump trucks). Recent deep learning-based methods have exhibited excellent performance in this field, including personal protective equipment detection

(Nath *et al.*, 2020), sewer pipe defect detection (Cheng and Wang, 2018), and crack damage detection (Cha *et al.*, 2017). Compared to traditional methods, deep learning methods can automatically extract CNN features from large amounts of the calibrated image dataset.

In contrast, previous studies have paid far less attention to *stuff* classes. As a type of *stuff* classes, fugitive dust has unique properties against other construction objects in several aspects: (1) shape: rigid construction objects (e.g., worker, hardhat) have regular shapes while the dust area is amorphous; (2) size: *thing* classes generally appear with little size variance, whereas dust-filled regions are highly variable in size; (3) opacity: dusty areas may mix with background regions if the dust concentration is too low; and (4) instances: dust is typically uncountable and has no well-defined instances (Caesar *et al.*, 2018). In addition to the challenge of extracting weak features, collecting dense dust emission samples is expensive and time-consuming. All these challenges make the previous methods for rigid objects inapplicable to the dust recognition problem.

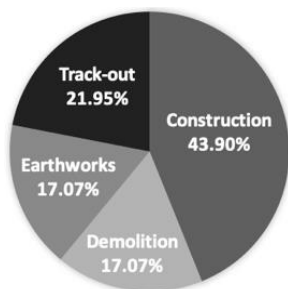
3. CONSTRUCTION DUST EMISSION DATASET & STATISTICS

Most of the emerging image datasets are *thing*-only datasets, such as ImageNet (Deng *et al.*, 2009) and COCO (Lin *et al.*, 2014). To better evaluate dust recognition algorithms, the authors first establish a CDE dataset covering various dust-related task activities and dust sizes. The constructed CDE dataset gathers a total of 500 dust deposition images from both real construction sites and online communities, of which dust emission images and non-dust emission images are roughly 50% each. Fig. 2 shows a few examples from the CDE dataset.

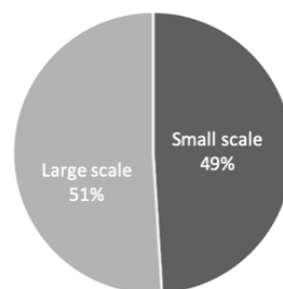


Fig. 2: Sample images from the CDE dataset.

Depending on the different potential impacts on dust pollution, activities on construction sites generally consist of four types: (1) demolition (e.g., blasting demolition and demolition of walls/roofs); (2) earthworks (e.g., soil-stripping, ground-leveling, excavation, and landscaping); (3) construction activities (e.g., concrete grinding and cutting); and (4) track-out activities, where fugitive dust emanates from vehicle traffic on unpaved roads. Fig. 3 illustrates the distribution of all dust types in the CDE dataset. Construction activities comprise 43.90% of the data samples, while the track-out activities, earthworks, and demolition are 21.95%, 17.07%, and 17.07%, respectively. The proposed CDE dataset covers different scenarios of common dust release jobs.



(a) dust type distribution.



(b) dust size distribution.

Fig. 3: Statistical analysis of the CDE dataset.

The risk of dust impacts is correlated with the magnitude of the emissions. Let the size index denote the relative area ratio of the dust release regions,

$$\text{Size index} = (w_i \cdot h_i) / (a_i \cdot b_i) \quad (1)$$

where w_i and h_i denote the width and height of the dust-filled bounding box, while a_i and b_i are the width and height of the i -th image.

According to the size index of dust regions, dust emission events comprise two categories: small (size index ≤ 0.25) and large (size index > 0.25). Fig. 3 shows the distribution of dust sizes in the CDE dataset. The results confirm that the CDE dataset has a uniform distribution of dust levels, which can help the object recognition algorithms to adapt to various dust emission events.

4. METHODOLOGY

Fig. 4 presents the overall architecture of the proposed dust emission monitoring approach, consisting of two main phases: dust feature extraction and ensemble SVM learning. Dust feature extraction is the basis for image classification, and it directly determines whether the classifier can accurately and efficiently identify dust images under different conditions. The authors argue that a robust dust recognition technique demands multiple dust cues to retrieve a wealth of dynamic information, implying the combination of several feature sets. On the other hand, selecting more features does not necessarily guarantee greater accuracy in classification tasks. Therefore, this work designs an ensemble SVM classifier for collaboration between a set of individual classifiers based on a multi-feature voting weighted mechanism. The ensemble strategy reduces dependence on a single decision while incorporating redundant components for enhanced classification performance.

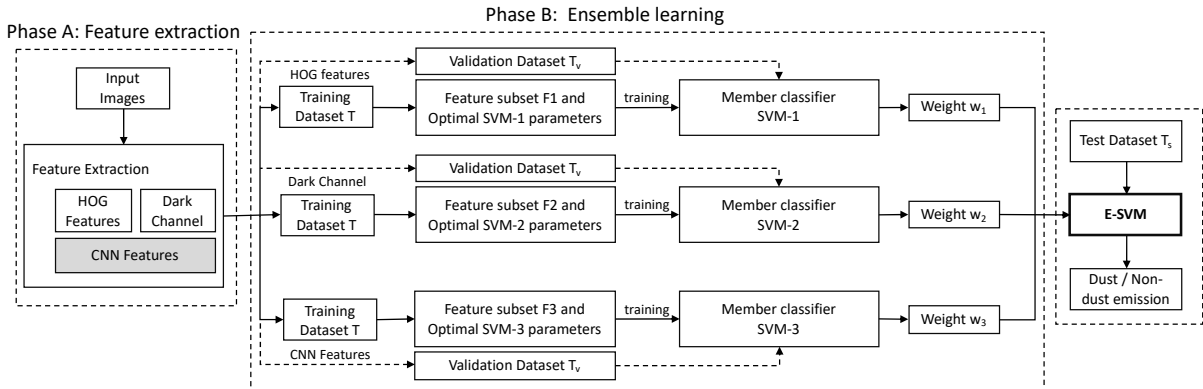


Fig. 4: The overall architecture of the proposed dust emission monitoring approach.

4.1 Dust Feature Extraction

This section provides an overview of three dust features, including HOG features, Dark Channel Prior, and CNN features, which feed into the E-SVM classifier to identify the dust emission image. The criteria for selecting these features are based on analyzing the dust's visual appearance under different conditions.

(1) HOG Features

The HOG can describe edges or local shape information in the image, which is popular in detecting rigid objects such as hardhats and workers (Memarzadeh *et al.*, 2013). This work incorporates the HOG feature to capture high-opacity dusty images, with a distinct pattern at the dust boundary. However, the HOG feature has difficulty in recognizing non-rigid dust in low concentration conditions where dust is mixed with complex backgrounds.

The HOG operates on a small set of connected regions called cells and further normalizes the local histograms of orientation across blocks for the pixels within each cell. In this work, the block size is 2×2 cells, and the size of each cell is 8×8 pixels. Each cell consists of a 9-bin histogram of orientation for $[0^\circ, 180^\circ]$ intervals.

(2) Dark Channel Features

The dark channel prior proposed by He et al. (2011), is a type of statistical feature based on the observation of haze-free images. Like the haze, airborne dust particles in the air affect optical images via light interactions. Thus, the authors investigate the dark channel prior to extract dust features from the images. The dark channel prior is sensitive to low-intensity dust but may fail to recognize over-bright objects, such as sky regions.

The low values in the dark channel usually result from the widespread shadows, dark or bright objects in the images. At least one-color channel (R , G , and B) has a very low intensity and tends to be zero in most non-haze regions. Formally, the dark channel J^{dark} used to describe dust features is as follows:

$$J^{dark}(\mathbf{p}) = \min_{c \in \{R, G, B\}} \left(\min_{\mathbf{q} \in \Omega(\mathbf{p})} (J^c(\mathbf{q})) \right) \quad (2)$$

where J^c is a one-color channel of the image \mathbf{J} , and $\Omega(\mathbf{p})$ is a local patch (15×15) at \mathbf{p} .

(3) CNN Features

While HOG features and dark channel priors can provide local levels of dust representations, the CNN features are excellent at capturing global scene semantics. Deep CNN techniques, such as VGG (Simonyan and Zisserman, 2015), have led to a series of breakthroughs in image classification. However, deep CNN models typically require a large-scale dataset for model training, which may limit their performance in the CDE dataset.

This work also investigates the efficacy of state-of-the-art CNN features. During the implementation, the authors pre-trained VGG-16 model parameters on the ImageNet dataset (Deng et al., 2009) without fine-tuning on the CDE dataset. The pre-trained VGG-16 model can automatically extract CNN features from the input images.

In general, a single feature may not adequately characterize dusty images well under different conditions, suggesting a combination of all three feature sets. Fig. 5 shows the three feature maps of the dust image emissions versus the non-dust emissions. These results prove the effectiveness of these selected features as useful descriptors for dust recognition.

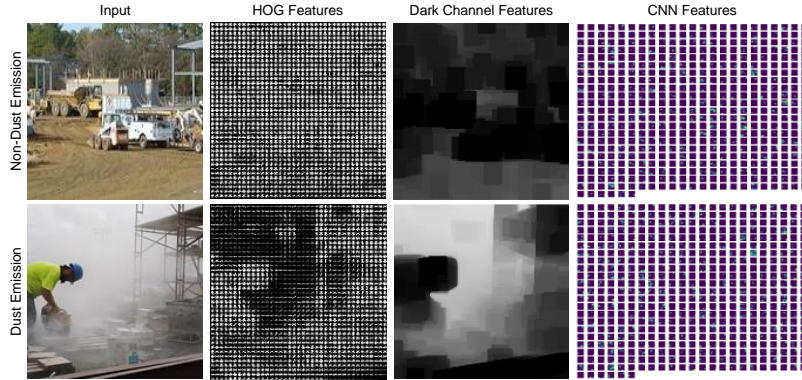


Fig. 5: Feature extraction for non-dust emission versus dust emission images.

4.2 Ensemble SVM Learning

After computing all the dust features above, the SVM will be able to identify the dust emission images. SVM is a well-known supervised learning algorithm for its outstanding performance in solving classification problems of small samples. Given a set of training data, an SVM algorithm can map inputs into the feature space and construct a separable hyperplane with the largest distance between the two classes using different kernel functions. For each training sample, the classifier predicts the image label as $y_i \in \{-1, +1\}$, where -1 and $+1$ correspond to “non-dust emission” and “dust emission”, respectively. The function $K(x_i, x_j) = \Phi(x_i) \cdot \Phi(x_j)$ defines an algorithm kernel, where x_i is the dust feature for training image i . The SVM classifier is modeled as

$$\begin{cases} \min \psi(\mathbf{W}) = \frac{1}{2} \|\mathbf{W}\|^2 + C \sum_{i=1}^N \zeta_i \\ \text{s.t. } y_t [\mathbf{W} \cdot K(x_i, y_j) + b] + \zeta_i \geq 1; i = 1, 2, \dots, N \end{cases} \quad (3)$$

where \mathbf{W} is the weight vector to determine the orientation of a hyperplane, b is the offset of the hyperplane from the origin, $\zeta_i \geq 0$ is a slack variable, N is the number of training images, and C is the regularization parameter.

Although a single SVM classifier may exhibit high classification performance on the test dataset, the proposed

E-SVM method can combine a set of individual classifiers into a more accurate decision-making process. This aggregation strategy will enhance the generality and robustness of the SVM classifier. In this paper, the E-SVM classifier consists of three member classifiers. Let S_{hog} , S_{dark} , and S_{cnn} denote the outputs of three individual SVM classifier, respectively. Let S denote the final decision score,

$$S = w_1 \cdot S_{\text{hog}} + w_2 \cdot S_{\text{dark}} + w_3 \cdot S_{\text{cnn}} \quad (4)$$

$$w_1 + w_2 + w_3 = 1 \quad (5)$$

where w_1 , w_2 , and w_3 are the weights of the 3-member SVM classifiers, respectively. If $S \geq 0.5$, the image will be classified as a dust emission event, whereas if $S < 0.5$, the image will be identified as a non-dust emission event.

The technical implementation involves a multi-feature weighted voting mechanism. Generally, the better classifiers account for the higher voting weights w_i . In this work, the authors evaluate the performance of a classifier with classification accuracy Acc :

$$Acc = N_c / N_a \quad (6)$$

where N_c is the number of the correctly classified samples, and N_a is the total number of samples.

By normalizing the classification accuracy of the 3-member SVM classifiers, the voting weight w_i for each classifier is as follows:

$$w_i = Acc_i / (\sum Acc_i), i = 1, 2, 3. \quad (7)$$

5. EXPERIMENTS & RESULTS

In this section, the authors have carried out a series of experiments on the CDE dataset to evaluate the effectiveness of the proposed method. During the training process, all the resized shapes of images are 256×256 , and the data augmentation techniques implement horizontally random flipping to generate diverse training samples and prevent severe over-fitting. The use of a 5-fold cross-validation method is necessary to obtain optimal hyper-parameters for each member SVM classifier. For the HOG feature-based classification method, an SVM with an RBF kernel and parameters $C = 10$ result in the best performance, while $C = 8$ and 5 are suitable for Dark Channel-based and CNN-based classifiers.

For each experimental analysis, this study executes three rounds and reports the mean classification accuracy to avoid biases. Table 1 shows the mean classification accuracy results of the E-SVM across all different feature sets, including single and multi-features. The single features include HOG features, Dark Channel features, and CNN features. In the E-SVM classifier, the voting weight of each member SVM classifier depends on their classification performance. The voting weights are 0.28 (SVM-1), 0.33 (SVM-2) and 0.39 (SVM-3), respectively. Table 1 indicates that the dark channel is more suitable than the HOG feature for capturing dust cues. Although the CNN feature reports better performance than either one alone, the combination of the three dust representations gives the best classification accuracy by taking advantage of both CNN and non-CNN features. This multi-feature fusion strategy can increase the recognition accuracy of CNN features by up to 4%.

Table 1: Experimental results of the E-SVM with different feature sets.

Features	HOG	Dark Channel	CNN features	Multi-features
Mean Acc (%)	69.14	73.40	82.98	87.23

Table 2: Comparison with state-of-the-art classification methods.

Classifier	Single-layer NN	KNN	Random Forest	Naïve Bayes	VGG-16	E-SVM
Mean Acc (%)	68.09	77.65	78.72	80.12	85.10	87.23

This section further compares the performance of the proposed E-SVM method with five state-of-the-art classification methods, including single-layered NN, KNN, Random Forest, Naïve Bayes, and VGG-16, using the same training and test datasets. As in the standard setting, the hyper-parameters of these methods remain at their default values in the Scikit-learn library (Pedregosa *et al.*, 2011) and Keras (Chollet *et al.*, 2015). The

authors have pre-trained the VGG-16 model parameters on the ImageNet dataset (Deng *et al.*, 2009), and then fine-tuned on the CDE training set. Table 2 demonstrates that the proposed E-SVM classifier outperforms all other typical classification approaches. The highest *Acc* is 87.23%, with multi-feature fusion. Compared to E-SVM, single-layer NN is the worst of all classification methods. Despite the outstanding performance of VGG-16 on image classification benchmarks, this deep CNN model shows inferior classification accuracy to the E-SVM. The reason for this performance difference is that the VGG-16 method requires large-scale samples for model training, which may limit its classification accuracy because of insufficient data. In contrast, the E-SVM method utilizes multiple types of dust features and combines a set of individual classifiers, thus yielding enhanced classification accuracy even within small-scale image datasets.



Fig. 6: Detection results: dust emissions.



Fig. 7: Detection results: non-dust emissions.

Fig. 6 and Fig. 7 show several successful recognition examples for dust emissions and non-dust emissions. The proposed E-SVM method works well in these four dust-related scenarios. Fig. 8 provides three failure cases. The E-SVM classifier labels (a) and (b) as non-dust emission images, with the non-dust emission score 0.61 and 0.52, respectively (and dust emission score 0.39 and 0.48, respectively), while classifying (c) as the dust emission image, with the dust emission score 0.79 (and non-dust emission score 0.21). By examining the extracted features from these failure cases, the illumination and bare mounds in the workplace negatively affect the classification results. The selected features also have difficulty in representing dust clouds with extreme low-opacity.

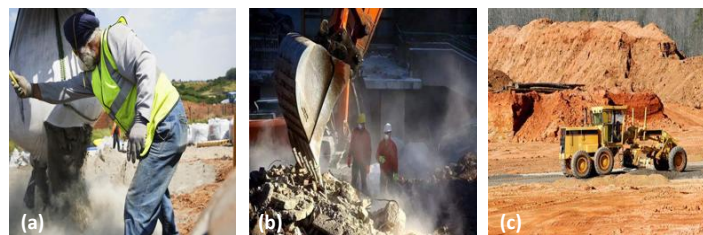


Fig. 8: Three failure cases. (a) and (b) dust emission images mis-detected as the non-dust emission, and (c) non-dust emission image mis-detected as the dust emission event.

6. CONCLUSION & FUTURE WORKS

In this paper, the authors have proposed an image-based dust emission monitoring method for construction activities. Investigating the general visual characteristics of the construction dust, this work explores different types of dust features, including CNN features and two non-CNN features (i.e., HOG features and Dark Channel) through a large number of experimental analyses. To enhance the accuracy of classification decisions, this work has designed an E-SVM classifier based on a multi-feature weighted voting mechanism. As shown in the numerical experiments, the number of features included significantly affect SVM classification accuracy. In

particular, the proposed E-SVM classifier with multi-features has the highest accuracy compared to individual SVM classifiers with a single feature. Compared to state-of-the-art classification algorithms, the ensemble classifier exhibits superior performance to other methods. Although the training data samples are very small, as they often occur in real-world applications, the proposed E-SVM method provides impressive classification accuracy than state-of-the-art classifiers and deep-learning methods.

By having access to automatic dust emission records in the workplace, this work can further attribute dust-related risks by providing detailed information such as task duration, frequency, and the type of activity involved. The proposed framework is scalable to integrate more image features, which will help enhance performance in the future by modeling other effective dust cues. Moreover, the presented CDE dataset is typically limited to illumination and weather conditions at construction sites, making it extremely challenging to create higher accuracy methods. While manually collecting dense and diverse data samples is costly and time-consuming, the authors will explore synthetic dust images to enrich and diversify the CDE dataset for model training and testing.

7. REFERENCES

- Caesar H., Uijlings J., and Ferrari V. (2018). COCO-Stuff: Thing and stuff classes in context, *Proceedings of the IEEE Conference on Computer Vision and Pattern Recognition (CVPR)*, 1209–1218.
- Cha Y.J., Choi W., and Büyüköztürk O. (2017). Deep learning-based crack damage detection using convolutional neural networks: Deep learning-based crack damage detection using CNNs, *Computer-Aided Civil and Infrastructure Engineering*, Vol. 32, No. 5, 361–378.
- Cheng J.C.P. and Wang M. (2018). Automated detection of sewer pipe defects in closed-circuit television images using deep learning techniques. *Automation in Construction*, Vol. 95, 155–171.
- Chollet F. (2015). Keras: The Python deep learning library, Keras.Io. <https://keras.io/>.
- Deng J., Dong W., Socher R., Li L.J., Kai L., and Li Fei-Fei (2009). ImageNet: A large-scale hierarchical image database, *Proceedings of the IEEE Conference on Computer Vision and Pattern Recognition (CVPR)*, 248–255.
- Health and Safety Executive (HSE) (2011). Levels of respirable dust and respirable crystalline silica at construction sites. <https://www.hse.gov.uk/research/rrpdf/rr878.pdf>.
- Institute of Air Quality Management (IAQM) (2018). Guidance on monitoring in the vicinity of demolition and construction sites. <http://iaqm.co.uk/guidance/>.
- Institution of Occupational Safety and Health (IOSH) (2014). Construction dust: An industry survey. <http://www.iosh.co.uk/dust>.
- He K., Sun J., and Tang X. (2011). Single image haze removal using dark channel prior, *Proceedings of the IEEE Transactions on Pattern Analysis and Machine Intelligence*, Vol. 33, No. 12, 2341–2353.
- Kim J., Ham Y., Chung Y., and Chi S. (2019). Systematic camera placement framework for operation-level visual monitoring on construction jobsites, *Journal of Construction Engineering and Management*, Vol. 145, No. 4, 04019019.
- Lin T.Y., Maire M., Belongie S., Hays J., Perona P., Ramanan D., Dollár P., and Zitnick, C.L. (2014). Microsoft COCO: Common objects in context, *Proceedings of the IEEE Conference on Computer Vision and Pattern Recognition (CVPR)*, 3686–3693.
- Memarzadeh M., Golparvar-Fard M., and Niebles J.C. (2013). Automated 2D detection of construction equipment and workers from site video streams using histograms of oriented gradients and colors, *Automation in Construction*, Vol. 32, 24–37.
- Nath N.D., Behzadan A.H., and Paal S.G. (2020). Deep learning for site safety: Real-time detection of personal protective equipment, *Automation in Construction*, Vol. 112, 103085.
- Park M.W. and Brilakis I. (2012). Construction worker detection in video frames for initializing vision trackers.

Automation in Construction, Vol. 28, 15–25.

Pedregosa F., Varoquaux G., Gramfort A., Michel V., Thirion B., Grisel O., Blondel M., Prettenhofer P., Weiss R., Dubourg V., Vanderplas J., Passos A., Cournapeau D., Brucher M., Perrot M., and Duchesnay E. (2011). Scikit-learn: Machine learning in Python, *Journal of Machine Learning Research*, Vol. 12, 2825–2830.

Simonyan K. and Zisserman A. (2015). Very deep convolutional networks for large-scale image recognition. *arXiv:1409.1556 [cs]*.

Wu Z., Zhang X., and Wu M. (2016). Mitigating construction dust pollution: state of the art and the way forward, *Journal of Cleaner Production*, Vol. 112, 1658–1666.

Xing J., Ye K., Zuo J., and Jiang W. (2018). Control dust pollution on construction sites: What governments do in China? *Sustainability*, Vol. 10, No. 8, 2945.

Zuo J., Rameezdeen R., Hagger M., Zhou Z., and Ding Z. (2017). Dust pollution control on construction sites: Awareness and self-responsibility of managers, *Journal of Cleaner Production*, Vol. 166, 312–320.

NON-MONOTONIC REASONING FOR AUTOMATED PROGRESS ANALYSIS OF CONSTRUCTION OPERATIONS

Karsten W. Johansen, Rasmus O. Nielsen, Carl Schultz, Jochen Teizer
Aarhus University

ABSTRACT: Real-time locating sensing (RTLS) systems offer significant potential to advance the management of construction processes by potentially providing run-time access to the locations of workers, equipment, and materials. As research with commercially-existing technologies over the past decade has shown, each system has distinct advantages and limitations once tested in the harsh construction environment. While some technologies show high investments and poor performances for indoor work environments, many generate large data sets that are somewhat difficult to process in a meaningful way. Unfortunately, little is still known regarding the practical benefits of converting raw data into meaningful information, effectively impeding widespread adoption in construction. This paper investigates large data sets, using Ultra-Wideband (UWB) sensing, that contain real-time, mobile resource location tracking data from very dynamic construction environments. The focus of this paper is on providing meaningful, semantically rich analysis using non-monotonic reasoning via Answer Set Programming (extended to support spatial and temporal reasoning), a logic programming paradigm developed within the Artificial Intelligence (AI) community, in the context of real-world construction applications of safety and productivity (both should go hand-in-hand). The work demonstrates the applicability of RTLS for monitoring labor tasks in work environments.

KEYWORDS: Artificial intelligence, building information modeling, real-time location sensing, ultra-wideband.

1. INTRODUCTION

Construction projects rely heavily on construction project planning and management, to get work done on schedule, at the right quality, and within the budget assigned for it. Unfortunately, processes and methods are still fixed in conventional ways and are therefore not flexible enough with respect to unforeseen events or tasks that may occur during a project. Some of the most common construction site issues relate to poor organizational structures, causing ineffective communication among project stakeholders, resulting in multiple types of waste (Neve et al., 2020). An example is the common practice of *manual* weekly to bi-weekly internal project updates to managers and engineers, which, being manual, is labor-intensive, subsequently slow, and potentially error-prone (Grau et al. 2009). Studies to the current practice show, 38% of work time is spent on activities that could have been avoided with better planning (i.e., work time wasted), which is relatively high compared to other sectors such as manufacturing with only 12% of wasted work time (Aziz and Hafez, 2013).

Solving the time delay issue, going from a weekly status to an hourly or perhaps per minute update, would perhaps address these issues. Accurate and timely information about construction progress would also improve safety and quality by enabling project managers to plan for subsequent tasks to be undertaken in a more optimal order (Teizer et al. 2017). Moreover, moving from a *manual* to an *automatic* process for obtaining progress update information would save yet many workhours.

Research on automatic progress monitoring have thus far focused on technology or processing-heavy approaches such as image-based, laser scanning, radio frequency identification (incl. ultra-wideband), global navigation satellite system, and unmanned aerial vehicles (Alizadehsalehi and Yitmen, 2016). Common to all of these approaches is the high demand on data processing requiring comprehensive data analysis tools, like Shahandashti et al. (2011), Cheng et al. (2013), and Vasenev et al. (2014) have experienced. Furthermore, many recent approaches rely on computer vision, which work well in unobstructed work spaces (Par et al., 2012; Memarzadeh et al. 2012; Yang et al., 2014; Zhu et al., 2016; Bügler et al., 2017; Luo et al. 2018). They have, however, a number of drawbacks with respect to construction progress monitoring: image resolution is often not sufficient to detect progress on smaller time-consuming details, and images do not penetrate built objects and thus progress that takes place is invisible (unless the same location is periodically revisited). Manual placement and management of image capture devices also limits the practical value of relying on computer vision exclusively to monitor all aspects of construction project progress.

Thus, this project investigates the possibility to determine the states that construction site personnel are in by emphasizing domain modeling, knowledge engineering, formal logic-based reasoning, and the placement of

numerous *simple* sensors. We investigate whether a software system can be developed to automate progress tracking based on knowledge from the site, what activity state construction site personnel has been in throughout a work day, and be able to give an explanation, based on the domain knowledge, on how the system came to the proposed explanation.

The way that this project varies from earlier (manual) approaches (e.g., CII 2010), is that the applied Artificial Intelligence (AI)-based software (specifically, Answer Set Programming) does not rely on a trained model from enormous amounts of data, but instead relies on formalized expert knowledge, where specified rules allow the system to generate hypotheses of the activities that are being undertaken. Figure 1 illustrates a simplified overview of the approach used in this study. Construction site personnel (incl. workers and foremen) are tracked using Ultra-Wideband (UWB) sensing and expert knowledge on construction is formalized as facts and rules in the logic programming system. This system is used to generate hypothetical explanations of site construction personnel activities (e.g., masonry or iron work subcontractor) and work states (e.g., direct, indirect, travel, break times) that are consistent with the generated sensor data in order to inform project managers about construction project progress.

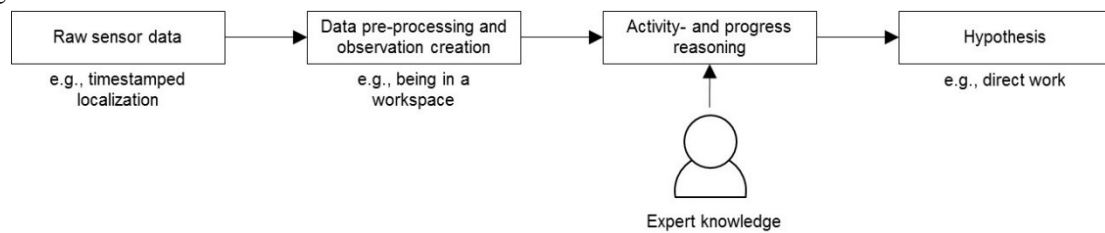


Fig. 1: Overview of research approach

2. BACKGROUND

2.1 Localization in Lean Construction

Lean construction is the concept of optimizing a construction process in terms of time, price, quality, safety, and waste (Womack and Jones, 1997). Unlike lean manufacturing, lean construction is project-based, and thus the factors that determine how processes can be optimized are highly project-specific. Moreover, measuring process quality is harder and more expensive to carry out. Lean construction's progress measures often include weekly or bi-weekly meetings, where the state of as-planned and as-built is compared. This is more time consuming and less agile than the automated process in the manufacturing-world, where measurements are taken continuously.

To collect information about the as-built state of a construction site at a higher temporal resolution beyond only weekly updates, we seek to automate progress monitoring. Different approaches have been carried out (Alizadehsalehi and Yitmen, 2018). In recent years, considerable research effort has focused on using localization to support lean construction, for example, via computer vision or wireless tracking.

Vision, as one approach, is used to automatically interpret video streams collected from the construction site at regular intervals and translate the semantic content into construction project progress. However, limited field-of-view and big data can limit the applicability (Shahandashti et al., 2011; Park and Brilakis, 2012; Teizer, 2015). Ultra-Wideband (UWB) technology (Cheng et al., 2010; Cheng et al., 2011) offers as alternative approach. Like any other Real-Time Location Sensing (RTLS) technology, UWB has also limitations (Vasenev et al., 2014; Golovina et al., 2016). Thus we intend that our system, based on UWB and abductive reasoning, is complemented with other approaches in practice. Posture recognition, for example, helps to determine, what high-level activity a worker is carrying out (Ray and Teizer, 2012; Valero et al., 2016; Rye et al., 2020). However, posture and RTLS data require fusion, as shown successfully by Migliaccio et al. (2013) and Cheng et al. (2013). Another important source of data is three-dimensional (3D) information. UAV (e.g., Siebert and Teizer 2013) is often used to record 3D as-built information (Bosché et al., 2015; Braun et al., 2020). The obtained point clouds are linked to Building Information Modeling (Brilakis et al., 2010; Golparvar-Fard et al., 2009).

2.2 Construction site status monitoring

Ultimately, the information that we seek to supply to project managers is whether certain planned construction tasks have been undertaken. However, we cannot directly 'sense' task completion and instead use sensor data about worker location to infer the *probability* of work being done. We adopt the common approach of decomposing so-

called ‘high level’ tasks into a hierarchy of subtasks that can be more reliably reasoned about based on sensor data (e.g., Zolinger et al. (2005)). Examples of subtasks that contribute to higher-level tasks are analyzed according to the guide of activity analysis (CII, 2010).

Given sensor data, our system needs to infer subtasks that are consistent with this sensor data. For example, given a timestamped series of geo-referenced locations associated with a particular worker (e.g., tracked UWB tags attached to personal protective equipment (PPE)) our system may infer that the worker has moved from region A to worksite B where they remained for some time, and then moved back to region A . Moreover, given the time spent at worksite B our system may infer progress on task X assigned to the worker that can only be undertaken using a particular machine at worksite B .

Such inferences are only plausible, tentative explanations of the data: if it was indeed the case that the worker undertook these activities then we would expect such sensor readings. However, many other scenarios would also result in these sensor readings - what if the PPE with the tags were accidentally swapped between workers? Given this new information our system would need to be able to revise its previous inferences. This kind of explanation-based hypothetical reasoning is a form of *abduction* (in contrast to deduction in which inferences are never retracted). The challenge in abductive reasoning is to efficiently produce a select few useful hypotheses that are justified from the data, out of the enormous multitude of hypotheses that are also consistent with the data available.

To put our research on a formal footing, consider the fundamental equation of inference (Michalski 1993):

$$BK \wedge H \models Obs$$

Background Knowledge (BK) is a set of *IF-THEN* rules between propositions, and facts that we know to hold in the current setting such as the 4D BIM of the construction project, the up-to-date worker roster, current time of day, construction project plan and task schedules, etc.; **observations** (Obs) are represented as symbolic facts annotated with probabilities, derived directly from sensor data; **hypotheses** (H) are facts that, when combined with BK , entail the observations. **Deduction** is the process of inferring Obs given H and BK . **Abduction** (Thagard and Shelley, 1997) is the process of inferring H given BK and Obs , such that background knowledge alone is not enough to explain the observations ($BK \not\models Obs$), the hypothesis is not inconsistent with background knowledge ($BK \wedge H \not\models \text{false}$) and the hypothesis is sufficient to explain the observations together with background knowledge. Our abductive reasoning module is implemented using **Answer Set Programming (ASP)** (Gebser et al., 2007; Marek and Truszczynski, 1999).

ASP is a declarative logic programming language that is used to represent and reason about semantic information in a given application domain (such as 4D BIM and safety) in the form of facts and rules, and has an in-built search engine for finding models (combinations of deduced facts) that follow from the given premises. In the context of logic programming, the rules in BK that provide the basis for abductive reasoning are a set of Horn clauses of the form: $h \leftarrow b_1, \dots, b_n$, where proposition h is true (the rule head) if propositions b_1, \dots, b_n are all true (the rule body). We represent a 4D BIM in ASP as ASP facts, background knowledge about construction activities are formalized as ASP rules, and valid hypothetical explanations are encoded as ASP models discovered by the ASP search engine.

The role of abduction in construction progress analysis is further explained in the next section.

3. METHODS

3.1 Sensor Data Collection

Our dataset consist of trajectory data of workers on a real construction site, recorded during winter months over the course of 6.5 hours of work time (including breaks). The data was produced using UWB-technology (Sapphire DART system, model H651). This system has an accuracy of ± 30 cm (Cheng et al., 2011). Each recording event (aka. datum) consists of the following items:

- *Type*: Data header describing the type of information in the data point (tag position)
- *TagID*: 8 digits HEX value as a unique identification number of the tag
- *X, Y, and Z*: Local x, y, z-coordinates
- *BatLvl*: Battery power level of the tag (14 means full)
- *TimeStamp*: Timestamp of measurement Unix-format
- *Unit*: Message unit
- *DQI*: Data quality Indicator (lower means higher quality)

The UWB data set contains trajectory data from 31 tags using 6 mid-gain receivers. These tags have different frequencies, transmission power and form the following specifications (Figure 2):

- *Frequencies:* 1, 15, and 60 Hz
- *Transmission power:* 30 and 1000mW
- *Tag form factors/format:* Badge- and asset-type tags



Fig. 2: Images of work environment (concrete masonry unit saw and columns), UWB tag on worker’s helmet and UWB tags on mobile crane hook, UWB reference tag on tripod and UWB receiver (from left to right image)

A laser scan of the site is shown in the plan view of Figure 3 (background of left image). This depicts the as-built situation during data recording. Furthermore, the image shows the reference tag (RT), from which the UWB system calibrates, and the UWB receivers called B1-B6. The left image illustrates raw data to a single UWB tag with the ID 0000080E. The data recording rate for this ID was 15 Hz, using 30 mW power. The raw data contains significant noise which we resolve through preprocessing as described in the following section.

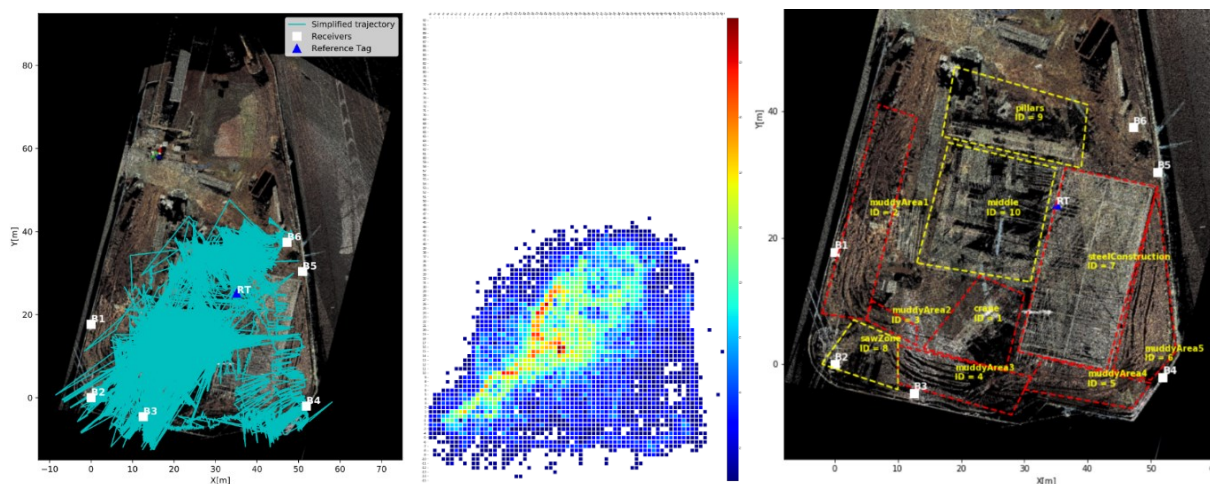


Fig. 3: Raw data (left image) and heatmap (middle) to a UWB tag, and identification of work and restricted areas (yellow and red colors, respectively) (right)

3.2 Sensor Data Preprocessing and Observation Creation

Data was preprocessed in Python using the packages Jupyter (2020), Pandas (2020), and Traja (2020).

3.2.1 Filtering

Filtering of speed: Traja (2020) comes with a function that calculates the speed between all data points. With this information, and the background knowledge that none of these tags were placed on vehicles, we can infer that speeds above 2 m/s (approx. equivalent to 7 km/h) would only be caused by noise in the system and are thus filtered out.

Savitzky–Golay filtering (SG): The SG-filter (Schafer 2020) is a smoothing filter, its purpose is to remove noise without removing the data tendency. The SG-filter is built on the principles of convolution and fits small subsets of the data with a low-degree polynomial. This process reduces the noise that does not reach speeds above 2 m/s.

Filtering with Ramer-Douglas-Peucker algorithm (RDP): Subsequently, the RDP-algorithm (Ramer, 1972) is used to reduce the number of redundant points in the data. The purpose of the RDP algorithm is to find a curve that closely fits the data and represent it with as few points as possible.

Since many of the tags ran at 60 Hz, large amounts of redundant data was produced for tags staying in nearly identical position. Thus, we identified and removed data points that were spatially close enough (within an *epsilon* threshold distance using the Hausdorff metric) to be registered as the same spatial location.

Based on the data we derive the following three kinds of information:

- 1) *Time frames during which certain tags are in certain areas of the construction site:* The construction site has been annotated with polygons defining 10 zones, divided into two zone categories: (1) allowable areas the masonry subcontractor was permitted to enter, shown as yellow and (2) restricted areas shown as red stamped lines in Figure 3 (right image). All the areas are annotated with an ID and a name.

We represent time intervals during which a worker or vehicle (a piece of heavy construction equipment) is located in a zone using the predicate *inArea/3*, as illustrated in lines 1-7 in Figure 4.

- 2) *The number of data points in squares of 1 by 1-meter per time slot:* In order to produce information about which locations were more or less frequently occupied, we partitioned the site into a grid consisting of 1m by 1m cells, and divided the recording period into 10 time intervals of equal duration. Trajectory data was then assigned to the corresponding grid cell and time interval, as illustrated in lines 8-17 in Figure 4 that is used to generate a heatmap as illustrated in Figure 3 (middle image).
- 3) *All IDs, areas, coordinates, first- and last-timestamps:* These define the bounds of the answer sets that ASP must check for contradiction and generate explanations. The predicates of these are shown from line 18 to 21 in the textbox shown in Figure 4.

```

1 %-----In Area-----
2 %holds(inArea(ID,AreaName,interval(Timestamp_start,Timestamp_end))).
3 holds(inArea(id000027E7,crane,interval(0,4142))).
4 ...
5 holds(inArea(id0000671D,steelConstruction,interval(5466,6473))).
6 ...
7 holds(inArea(id0000080E,sawZone,interval(6036,6069))).
8 %-----Heatmap V1-----
9 %heatmap(X_coordinate,Y_coordinate,Count_of_unique_IDs).
10 heatmap(-8,-15,0).
11 ...
12 heatmap(21,17,15).
13 %-----Heatmap V2-----
14 %heatmap(interval(Interval_start,Interval_stop),X,Y,Count_of_unique_IDs).
15 heatmap(interval(0,677),3,5,5).
16 ...
17 heatmap(interval(677,1354),3,5,1).
18 %-----IDs,Areas & TS-----
19 ycor(-15..93).
20 xcor(-8..75).
21 interval(0,677,...,6770,7447).

```

Fig. 4: Code to generate observations

```

1 move_from_A_To_B(Id, From, To, Timestep1,Timestep2) :-
2 holds(inArea(Id,From,interval(_,Timestep1))),
3 holds(inArea(Id,To, interval(Timestep2,_))).
4
5 intervals(T1,T2):-holds(inArea(_,_,interval(T1,T2))).
6
7 moving_bricks(Id,T1,T2):-
8 intervals(T1,T2),
9 Area1=pillars,
10 Area2=sawZone,
11 idsInFrame(Id),
12 move_from_A_To_B(Id, Area1, Area2, T1,T2).
13
14 {
15 move_from_A_To_B(Id, From, To,
16 Timestep1,Timestep2):From=pillars,To=sawZone;
17 move_from_A_To_B(Id, From, To,
18 Timestep1,Timestep2):From=sawZone,To=pillars
19 }:-moving_bricks(Id,Timestep1,Timestep2).
20
21 {
22 moving_bricks(Id,Timestep1,Timestep2):
23 intervals(Timestep1,Timestep2),idsInFrame(Id)
24 }.
25 :-moving_bricks(Id,Timestep1,Timestep2):
26 intervals(Timestep1,Timestep2),idsInFrame(Id).

```

Fig. 6: Code for activity reasoning

3.3 Activity and progress reasoning

Based on the observations as illustrated in Figure 4, in this section we define ASP rules for reasoning about construction activities from sensor data, which in turn are used to reason about construction progress.

3.3.1 Activity reasoning

Moving bricks: A worker (helper) walks from *sawZone* to *pillars*, or from *pillars* to *sawZone*. This is modeled in the code listing of Figure 5.

Laying bricks & Running saw: To lay bricks the masonry worker must be in the *pillars* area for a minimum of 15 minutes continuously. Similarly, to run the saw an (authorized) worker must stay in the vicinity of the saw for 15 minutes. The length is typical not a problem, because several bricks are cut in a row and require preparation. The corresponding ASP rules are presented in Figure 6.

```

1 laying_bricks(Id,T1):-
2   Duration>15*60, %15 min
3   Area=pillars,
4   holds(durationInArea(Id,Area,T1,Duration)).
5
6 running_saw(Id,T1):-
7   Duration>15*60, %15 min
8   Area=sawZone,
9   holds(durationInArea(Id,Area,T1,Duration)).

```

Fig. 6: Code for activity in work areas

```

1 on_break(Id,T1):-
2   Duration>20*60, %20 min
3   Area=middle,
4   T1>2*60*60, %9 am + 2 H = 11am
5   holds(durationInArea(Id,Area,T1,Duration)).

```

Fig. 8: Code for break time

```

1 not_moving(Id,T1):-
2   Duration>1*60*60, %1 hour
3   area_code(Area),
4   holds(durationInArea(Id,Area,T1,Duration)).

```

Fig. 7: Code for not moving

```

1 {
2   moving_bricks(Id,T1,T2):intervals(Timestep1,Timestep2),idsInFrame(Id);
3   laying_bricks(Id,T1,T2):intervals(Timestep1,Timestep2),idsInFrame(Id);
4   running_saw(Id,T1,T2):intervals(Timestep1,Timestep2),idsInFrame(Id)
5 }1:-direct_work(Id,T1,T2).
6
7 {
8   on_break(Id,T1,T2):intervals(Timestep1,Timestep2),idsInFrame(Id);
9   not_moving(Id,T1,T2):intervals(Timestep1,Timestep2),idsInFrame(Id)
10 }1:-not_direct_work(Id,T1,T2).
11
12 :-not_direct_work(Id,T1,T2),direct_work(Id,T1,T2).

```

Fig. 9: ASP-formulation for progress monitoring

Not moving: In our current model, staying in the same area for more than an hour is assumed to not correspond to carrying out work at the construction site. The rule for *not_moving* is shown in Figure 7.

On break: If personnel stay in the designated break area for more than 20 minutes continuously it would mean that they are on break. The corresponding ASP rules are shown in Figure 8.

3.3.2 Progress reasoning

This section describes the process of going from activities to progress reasoning. To do this, two simple rules are formulated. One rule describing what ‘direct work’ means, and another rule describing what ‘not direct work’ means. These two rules are created with the building blocks that were formed in the previous section. The activities that fall under the category ‘direct work’ are moving bricks, laying bricks, and operating the saw. In the category of ‘not direct work’ is break and not moving.

Figure 9 shows the ASP-formulation of these rules. The rules are built in a way that allows the user to make a hypothesis that ASP is going to reason about from the earlier defined activities and their observations.

4. EXPERIMENT AND RESULTS

The localization data were collected on a construction site over a whole day, with UWB tags and receivers, where all of the work was conducted on the ground level. The construction workers were equipped with the UWB-tags on their helmets, and then UWB receivers were placed across the site. At the point of recording of the data, steel girders were already erected, but there were no solid concrete walls, meaning the amount of heavy obstacles were limited to the cranes and heavy machinery on the site.

There were a total of 31 tags deployed, which sampled with the frequencies of: 1 Hz, 15 Hz, 30 Hz, and 60 Hz.

6 mid-gain receivers were placed to collect the information as a relative positioning system. For a tag’s sample to be recorded it had to be connected to at least 3 receivers, otherwise that sample would be discarded. The measurement error range is 30 cm. The data was filtered as described in section 3.2.1.

4.1 ASP-Experiments

We use ASP to identify all time intervals during which a worker is carrying out *direct work* (as described in Section 3.3.1) that contributes to a construction task. The total sum of the duration of these intervals is used as a qualitative assessment of construction progress. We implemented our rules in the ASP system Clingo (Gebser et al., 2016).

Each ASP solution corresponds to a hypothesis about work carried out that is consistent with the given sensor data. We employed Clingo’s native optimization feature to find the hypothesis that consists of the largest number of *direct work* predicates as a qualitative upper bound on construction progress. The code listing is presented in Figure 10. The optimization process took approximately 30 seconds to complete, and reported that the optimal hypothesis has a direct work duration of 22894 sections (~6 hours work time) and ~0.5 hours of break time.

```

1 intervals_in_id(Id,T1,T2):-holds(inArea(Id,_,interval(T1,T2))).
2
3 {
4   direct_work(Id,T1,T2):Id=id00006289,
5     intervals_in_id(Id,T1,T2)
6 }.
7 :-not direct_work(Id,T1,T2):Id=id00006289,
8     intervals_in_id(Id,T1,T2).
9
10 total(S) :- S = #count{ T1 :direct_work(Id,T1,T2)}.
11 #maximize{C :total(C)}.

```

Fig. 10: ASP-formulation for progress monitoring

4.2 Preliminary Results

Deploying sensors on workforce for location tracking in construction workplaces is bound to cause some potential complications about workers' privacy. This is of course a concern, as it might bring a stop to the practicality of the implementation of the proposed system. While research as this might search the boundaries, additional work is important that data stays confidential (persons remain unidentifiable). In brief, for a system to be compliant with the General Data Protection Regulation (GDPR) (EU 2020), additional research is necessary. Some piloting construction site have seen implementation were data stays on site and does not record any personal data, and if so, only for sporadic, temporary monitoring purposes only. The data shown comes from such a recording. As such, the data does not reveal the personnel's professional background.

The data shown in Figure 11 are the line plots of filtered data, while the heat maps are raw data visualizations. This is because error spikes on a heat map will only be shown as a single point, whereas on a line plot, a line is created. The purpose of a heat map is to see how long a worker has stayed in the same area, and not the trajectories as is the goal of the line plot. Hence, there is no need or use to filter the data on the heat map when looking for the time a worker spent in the work areas present on a construction site.

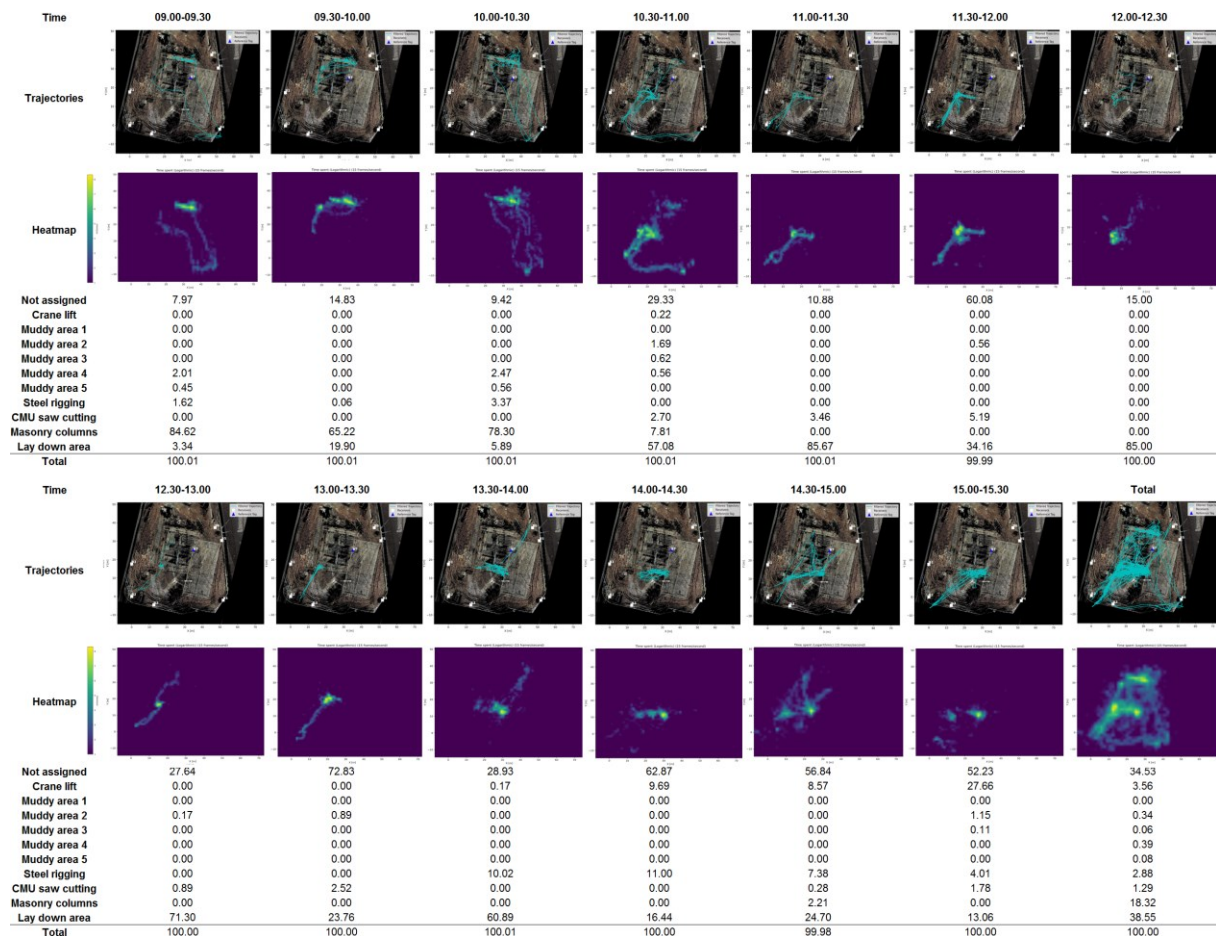


Fig. 11: Automated analysis of the 30-minute intervals of the UWB data (incl. filtered trajectory, heatmap and time spent in workspaces) to tag ID 000080E

Because the workers wearing the UWB tags tend to stay in the same area for longer periods of time rather than walking around on the site, the scale is logarithmic. The reason is: With a linearly scale, the amount of time in one spot when walking is only a small fraction of the maximum value of a stationary position, resulting in no walk-paths on the heat map. With a logarithmic scale, the paths taken are still visible, while clusters are punished more for the higher values.

The filtering process of the trajectories are done in four steps: (a) filtering on speed, (b) filtering on displacement, (c) smooth filtering, and (d) rdp-filtering. By going through these filtering methods, not only do the trajectories get filtered in a manner such that ‘human-like’ trajectories emerge, but also removing unnecessary data points from the set. By removing the unnecessary data points from the set, the ASP processing time gets optimized. In the case of the tag 0000080E (Figure 11) the total amount of data points collected over the course of the data collection are 135646. At the end of the filtering process, only 3404 data points are left, corresponding to 2.5 % of the originals.

Tag ID: 0000080E

In the case of 0000080E, an analysis was made every half hour. The full workday stretched from 09:00 to 15:30, resulting in a total of 13 half-hourly windows, where each window is analyzed with a filtered trajectory line plot, and a heatmap with the raw data. Based on the trajectory of the line plots, it is calculated how big of a percentage of the half hour the tag spent in a zone (set according to Figure 3, right image). Note that the annotated zones do not take up the full area of the construction site, leaving parts of the constructions site uncovered with a zone. In the case of a data point placed outside the zones, the data point will be added to a default zone called ‘Not assigned’.

From the calculations of percentage time spent in a zone, it is revealed that the tag spends the 1.5 hours primarily at the ‘masonry columns’. After the first 1.5 hours the tag leaves this area and starts staying at the middle of the construction site, while making small trips around the construction site. This is done for the rest of the day. In Figure 11, the tag gets calculated to stay in the ‘not assigned’ zone, for a total of 34.5 % of the time. But as it can be seen from the half hourly plots on the heatmap, the tag still stays in the vicinity of the middle zone. With the small trips around the site, and majority in the middle zone, this could be the job of a field superintendent. In the heatmap with all the raw data, the color of the zone ‘masonry columns’ and the color at the middle, are nearly the same. The middle of the heat map is more yellow, than at the ‘masonry columns’. This is because the scale is logarithmic; the difference between the two points is a factor of e as it is the natural logarithm that is used.

Tag ID: 0000671D

The parabolic movements approximate the movements of the tagged hook (aka. crane block) of the mobile crane imply crane swings/lifts (Figure 12). Most of the time, the tag tracks the rotation from right to left and vice versa. Later in the day some spikes accurse, but as to know if these are actual movements are errors is hard to say. For example, the straight lines are not directly from the center of the crane, but with an offset. It seems unlikely that this would be movement from the crane hook. To be the crane hook, the crane operator would have to turn the crane in a constant motion, and extent the crane boom in an accelerating motion, which seems unlikely.

Tag ID: 00007821

This tag has the same characteristics as 0000671D, but with more data points, which could be the result of a 60 Hz tag where 0000671D is a 1 Hz tag. From an ASP-analysis it emerges that the tag travels from the area named ‘crane 1’ to ‘crane 2’ within 5 minutes 14 times and the other way 15 times. The mentioned swing areas, the higher resolution trajectory, and the number of calculated trips are shown in Figures 13 and 14, respectively.

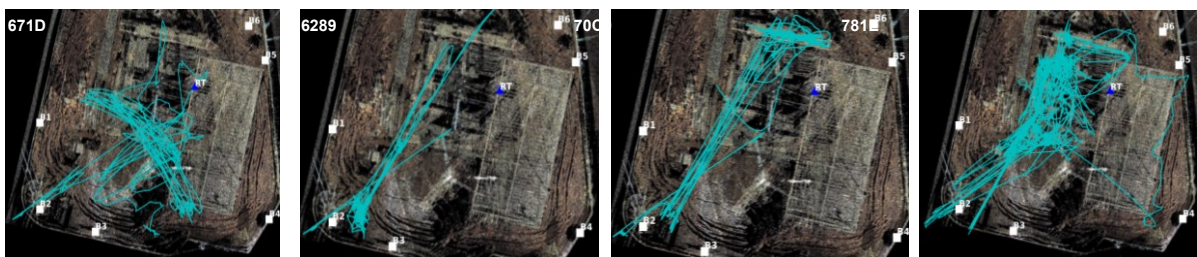


Fig. 12: Trajectory data to UWB tag-IDs ending in 671D, 6289, 70C0, 781E (left to right images)

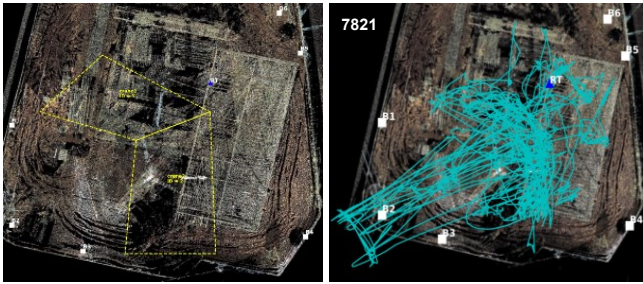


Fig. 13: Mobile crane load swing areas (left) and UWB tag on crane block with ID ending in 7821 (right)

```
Solving...
Answer: 1
query_4(crane2,crane1,id00007821,15) query_5(crane1,crane2,id00007821,14)
SATISFIABLE
Models      : 1
Calls       : 1
Time        : 0.040s (Solving: 0.00s 1st Model: 0.00s Unsat: 0.00s)
CPU Time    : 0.031s
```

Fig. 14: Number of crane swings

```
Solving...
Answer: 1
query_4(pillars,sawZone,id000070C0,13) query_5(sawZone,pillars,id000070C0,9)
SATISFIABLE
Models      : 1
Calls       : 1
Time        : 0.436s (Solving: 0.00s 1st Model: 0.00s Unsat: 0.00s)
CPU Time    : 0.406s
```

Fig. 15: Number of worker movements

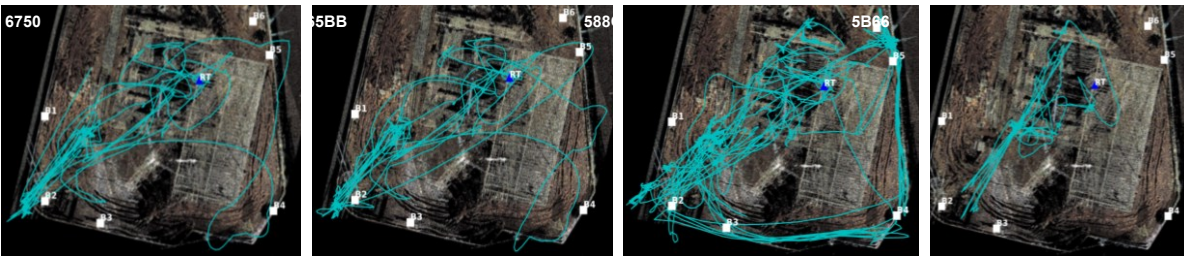


Fig. 16: Trajectory data to UWB tag-IDs ending in 6750, 65BB, 588C, 5B66, (left to right images)

Tag ID: 00006289

This tag spends 76 % of the workday at the saw, resulting in a total of 297 minutes or almost 5 hours. A few trips are made upwards to the ‘masonry columns’ in a direct line and then quickly back again. This could be the result of the saw operator seeking some clarification before continuing sawing the bricks in the sawing area (Figure 12).

Tag ID: 000070C0

This tag shows the opposite (Figure 12). In the beginning of the day, a few trips are made back and forth between the saw and the ‘masonry columns’. Otherwise the tag stays there. This suggests this a helper, who is in a supporting role of delivering the cut bricks to the brick layers. Data show that this tag stays around the ‘masonry columns’ starting midday. It seems an agreement has been made and another tag takes over the role of supplying bricks to the brick layers for the rest of the day. From an ASP-analysis the following result emerges, which shows the person travels from pillars to ‘sawZone’ within 5 minutes 13 times and the other way 9 times (Figure 15).

Tag ID: 0000781E

Spends most of the time in the middle zone while also staying in the ‘masonry column’ zone. It once made a trip along the side of the steel rigging work and returns to the ‘masonry columns’. This could have been done as out of curiosity, staying a bit in the same area at a time, and then walking back and forth between two center work areas on the construction site. The worker completely avoids the saw area, and only for one minute is present in a muddy area. This leads to believe this person is aware of where he is walking (Figure 12).

Tag ID: 00006750

This tag traverses around the construction site and does not have one major spot where it tends to stay throughout the day (Figure 13). 71 % of the time, it remains in unclassified areas; most times, it tends to stay in the lower left side of the construction site near the saw. This tag could correspond well with a person rigging material.

Tag ID: 000065BB

This tag has similarities with 00006750 in both the trajectories and the amount of time spent in the areas. The only difference is the resolution of the tag. Tags ending in 6750 and 65BB are worn by the same worker (Figure 13).

Tag ID: 0000588C

While the heat map looks like 0006750 and 000065BB, the line plot does not. Paths are clearly visible along the

security fence, but not all the way each time, and at difference distances along it. Also, the trips made is first done in last half of the day and are not done in a circular path all around the fence, but in perpendicular motions taking the same path back and forth. Otherwise, the majority of the work is done in the work areas at the middle. Why this is the case, it is hard to say, but trips are made in more intriguing paths than straight lines (Figure 13).

Tag ID: 00005B66

This tag stayed 64 % of the time in the center of the work area and 14 % at the ‘masonry columns’. The majority of the time, it stayed at the same area with very few trips inside the center area. For the first half of the day, it stayed at the center, but once goes to the ‘masonry columns’. It stayed there for the rest of the day, apart from a trip toward the end, where it went from the ‘masonry columns’ to the work area of the steel riggers (Figure 13).

5. CONCLUSION

Construction is experiencing an enduring change towards digitalization. Real-time location sensing (RTLS), as one example, intends to support lean principles. In this paper we have investigated whether construction project domain knowledge, formalized as logic programming *rules*, can be used to qualitatively assess the progress of a construction plan. In our system, sensor data collected from a construction site, specifically Ultra-Wideband (UWB) localization data, is used in the context of *abductive reasoning* to generate hypotheses about construction activities that are consistent with the observed sensor data. We implemented our system in Answer Set Programming (ASP), and undertook an empirical evaluation of one work day of trajectory data from a real construction project. The results show that ASP can be used to generate rich, qualitative information about the activities that took place. Computational runtime was practical, taking approximately 30 seconds to find ‘optimistic’ hypotheses of construction activities where direct work time was maximized which provides project managers with an upper bound on project progress. For instance, an optimistic hypothesis is an interpretation of the sensor data where workers were engaged in activities that directly contributed to particular construction tasks such as using a machine at a particular job site, in contrast to a ‘pessimistic’ hypothesis that a worker was forced to waste time waiting at the machine until another worker brought required materials; the sensor data in both interpretations is the same. Future work will focus on analyzing larger data sets and linking newly generated information to a Building Information Modeling (BIM) that serve in a digital building twin. Additional research may also investigate how (a) practitioners leverage runtime dashboards for as-planned vs. as-is schedule and cost comparisons, and (b) workers’ privacy and employment rights still can be respected and protected.

6. REFERENCES

- Alizadehsalehi, S., and Yitmen, I. (2016). The Impact of Field Data Capturing Technologies on Automated Construction Project Progress Monitoring. *Procedia Engineering*, 161, 97-103, <https://doi.org/10.1016/j.proeng.2016.08.504>
- Aziz, R.F. and Hafez, S.M. (2013). Applying lean thinking in construction and performance improvement, *Alexandria Engineering Journal*, 52(4): 679-695, <https://doi.org/10.1016/j.aej.2013.04.008>.
- Bügler, M., Borrmann, A., Vela, P.A., Teizer, J. (2017). Fusion of Photogrammetry and Video Analysis for Productivity Assessment of Earthwork Processes, *Computer-Aided Civil and Infrastructure Engineering*, Wiley, 32(2), 107–123, <http://doi.org/10.1111/mice.12235>.
- Braun, A., Tuttas, S., Borrmann, A. Stilla, U. (2020). Improving progress monitoring by fusing point clouds, semantic data and computer vision. *Automation in Construction*, 116, 103210, <https://doi.org/10.1016/j.autcon.2020.103210>.
- Bosché, F., Ahmed, M., Turkan, Y., Haas, C.T., Haas, R. (2015). The value of integrating Scan-to-BIM and Scan-vs-BIM techniques for construction monitoring using laser scanning and BIM: The case of cylindrical MEP components. *Automation in Construction*, 49, 201-213, <https://doi.org/10.1016/j.autcon.2014.05.014>
- Brilakis, I., Lourakis, M., Sacks, R., Savarese, S., Christodoulou, S., Teizer, J., Makhmalbaf, A. (2010). Toward automated generation of parametric BIMs based on hybrid video and laser scanning data. *Advanced Engineering Informatics*, 24(4), 456-465, <https://doi.org/10.1016/j.aei.2010.06.006>
- Cheng, T., Migliaccio, G.C., Teizer J., Gatti, U.C. (2013). Data Fusion of Real-time Location Sensing (RTLS) and Physiological Status Monitoring (PSM) for Ergonomics Analysis of Construction Workers, *Journal of Computing in Civil Engineering*, 27(3), 320-335, [http://dx.doi.org/10.1061/\(ASCE\)CP.1943-5487.0000222](http://dx.doi.org/10.1061/(ASCE)CP.1943-5487.0000222).

- Cheng, T., Venugopal, M., Teizer, J., and Vela, P.A. (2011). Performance Evaluation of Ultra Wideband Technology for Construction Resource Location Tracking in Harsh Environments. *Automation in Construction*, 20(8), 1173-1184, <http://dx.doi.org/10.1016/j.autcon.2011.05.001>.
- Cheng, T., Yang, J., Teizer, J., Vela, P.A. (2010). Automated Construction Resource Location Tracking to Support the Analysis of Lean Principles. *18th Annual Conference of the International Group for Lean Construction*, Haifa, Israel, July 14-16, 2010, 643-653.
- Cheng, T., Mantripragada, U., Teizer, J., and Vela, P.A. (2012). Automated Trajectory and Path Planning Analysis Based on Ultra Wideband Data. *Journal of Computing in Civil Engineering*, ASCE, 26, 151-160, [http://dx.doi.org/10.1061/\(ASCE\)CP.1943-5487.0000115](http://dx.doi.org/10.1061/(ASCE)CP.1943-5487.0000115).
- Cheng, T., Teizer, J., Migliaccio, G.C., Gatti, U.C. (2013). Automating the Task-level Construction Activity Analysis through Fusion of Real Time Location Sensors and Worker's Thoracic Posture Data. 2013 ASCE *International Workshop on Computing in Civil Engineering*, <https://doi.org/10.1061/9780784413029.079>.
- CII (2010). *Guide to Activity Analysis*. IR252-2a, Construction Industry Institute, University of Texas at Austin.
- Gebser, M., Kaufmann, B., Neumann, A., and Schaub, T. (2007). Clasp: A conflict-driven answer set solver. *Logic Programming and Nonmonotonic Reasoning*, 260-265.
- Gebser, M., Kaminski, R., Kaufmann, B., Ostrowski, M., Schaub, T., & Wanko, P. (2016). Theory solving made easy with clingo 5. In Technical Communications. *32nd Intl. Conf. on Logic Programming*. Schloss Dagstuhl-Leibniz-Zentrum für Informatik.
- EU Commission. General Data Protection Regulation. <https://gdpr-info.eu/>, Accessed May 25, 2020.
- Golparvar-Fard M, Peña-Mora F, Savarese S (2009). Application of D4AR – A 4-Dimensional augmented reality model for automating construction progress monitoring data collection, processing and communication. *ITcon*, 14, 129-153, <https://www.itcon.org/2009/13>.
- Golovina, O., Teizer, J., Pradhananga, N. (2016). Heat Map Generation for Predictive Safety Planning: Preventing Struck-by and Near Miss Interactions between Workers-on-Foot and Construction Equipment. *Automation in Construction*, 71, 99-115, <http://dx.doi.org/10.1016/j.autcon.2016.03.008>.
- Grau, D., Caldas, C.H., Haas, C.T., Goodrum, P.M., Gong, J. (2009). Assessing the impact of materials tracking technologies on construction craft productivity, *Automation in Construction*, 18(7), 903-911, <https://doi.org/10.1016/j.autcon.2009.04.001>.
- Luo, X., Li, H., Cao, D., Yu, Y., Yang, X., Huang, T. (2018). Towards efficient and objective work sampling: Recognizing workers' activities in site surveillance videos with two-stream convolutional networks. *Automation in Construction*, 94, 360-370, <https://doi.org/10.1016/j.autcon.2018.07.011>
- Marek, V.W. and Truszczyński, M. (1999). Stable models and an alternative logic programming paradigm. *The Logic Programming Paradigm*, 375-398.
- Memarzadeh, M., Golparvar-Fard, M., Niebles, J.C. (2012). Automated 2D detection of construction equipment and workers from site video streams using histograms of oriented gradients and colors. *Automation in Construction*, 32, 24-37, <https://doi.org/10.1016/j.autcon.2012.12.002>.
- Michalski, R.S. (1993). Inferential theory of learning as a conceptual basis for multistrategy learning. *Machine learning*, 11 (2-3), 111-151.
- Migliaccio, G.C., Cheng, T., Gatti, U.C., Teizer, J. (2013). Data Fusion of Real-time Location Sensing (RTLS) and Physiological Status Monitoring (PSM) for Ergonomics Analysis of Construction Workers. *CIB World Congress, Brisbane, Australia*, May 5-9, 2013.
- Neve, H.H., Wandahl, S., Lindhard, S., Teizer, J., Lerche, J. (2020). Determining the relationship between direct work and construction labor productivity in North America: Four decades of insights. *Journal of Construction Engineering and Management*, 146(9), 04020110, [https://doi.org/10.1061/\(ASCE\)CO.1943-7862.0001887](https://doi.org/10.1061/(ASCE)CO.1943-7862.0001887).
- Park, M.-W., Brilakis, I. (2012). Construction worker detection in video frames for initializing vision trackers, *Automation in Construction*, 28, 15-25, <https://doi.org/10.1016/j.autcon.2012.06.001>.
- Project Jupyter, 2020. URL <https://jupyter.org/>. Accessed: May 21, 2020.
- Project Pandas, 2020. URL <https://pandas.pydata.org/>. Accessed: May 21, 2020.

- Ramer, U. (1972). An iterative procedure for the polygonal approximation of plane curves. *Computer Graphics and Image Processing*, 1(3), 244–256, [https://doi.org/10.1016/S0146-664X\(72\)80017-0](https://doi.org/10.1016/S0146-664X(72)80017-0).
- Ray, S.J., Teizer J. (2012). Real-Time Construction Worker Posture Analysis for Ergonomics Training. *Advanced Engineering Informatics*, 26, 439-455, <http://dx.doi.org/10.1016/j.aei.2012.02.011>.
- Ryu, J.H., Alwasel, A., Haas, C.T., Abdel-Rahman, E. (2020). Analysis of Relationships between Body Load and Training, Work Methods, and Work Rate: Overcoming the Novice Mason’s Risk Hump. *Journal of Construction Engineering and Management*, 146 (8), 04020097, [https://doi.org/10.1061/\(ASCE\)CO.1943-7862.0001889](https://doi.org/10.1061/(ASCE)CO.1943-7862.0001889).
- Schafer, R. W. (2011). What is a Savitzky-Golay filter? Lecture notes. *IEEE Signal processing magazine*, 28(4), 111-117.
- Shahandashti, S.M., Razavi, S.N., Soibelman, L., Berges, M., Caldas, C.H., Brilakis, I., Teizer, J., Vela, P.A., Haas, C.T., Garrett, J., Akinci, B., and Zhu, Z. (2011). Data Fusion Approaches and Applications for Construction Engineering. *Journal of Construction Engineering and Management*, 137(10), 863-869, [http://dx.doi.org/10.1061/\(ASCE\)CO.1943-7862.0000287](http://dx.doi.org/10.1061/(ASCE)CO.1943-7862.0000287).
- Siebert, S., Teizer, J. (2013). Mobile 3D mapping for surveying earthwork using an unmanned aerial vehicle (UAV). *Proceedings of the 30th International Symposium on Automation and Robotics in Construction*, Montreal, Canada, August 11-15, 2013, <https://doi.org/10.22260/ISARC2013/0154>.
- Smarsly, K., Law, K.H., König, M. (2011). Autonomous structural condition monitoring based on dynamic code migration and cooperative information processing in wireless sensor networks. *Proc. 8th International Workshop on Structural Health Monitoring*.
- Teizer, J. (2015). Status Quo and Open Challenges in Vision-Based Sensing and Tracking of Temporary Resources on Infrastructure Construction Sites. *Advanced Engineering Informatics*, Special Issue Infrastructure Computer Vision, Elsevier, 29(2), 225-238, <http://dx.doi.org/10.1016/j.aei.2015.03.006>.
- Teizer, J., Melzner, J., Wolf, M., Golovina, O., König, M. (2017). Automatisierte 4D-Bauablaufvisualisierung und Ist-Datenerfassung zur Planung und Steuerung von Bauprozessen, VDI-Bautechnik, Jahresausgabe 2016/17, *Bauingenieur*, Springer, October 2017, ISSN 0005-6650, 129-135.
- Thagard, P. and Shelley, C. (1997). Abductive reasoning: Logic, visual thinking, and coherence. *Logic and Scientific Methods*, 413-427.
- Traja Developers, 2019. URL <https://traja.readthedocs.io/en/latest/>. Accessed: May 21, 2020.
- Valero, E., Sivanathan, A., Bosché, F., Abdel-Wahab, M. (2016). Musculoskeletal disorders in construction: A review and a novel system for activity tracking with body area network. *Applied Ergonomics*, 54, 120-13, <https://doi.org/10.1016/j.apergo.2015.11.020>.
- Vasenev, A., Pradhananga N., Bijleveld, F., Ionita, D., Hartmann T., Teizer, J., and Dorée, A. (2014). An Information Fusion Approach for Filtering GNSS Data Sets collected during Construction Operations, *Advanced Engineering Informatics*, Elsevier, 28, 297-310, <http://dx.doi.org/10.1016/j.aei.2014.07.001>.
- Womack, J.P and Jones, D.T. (1997). Lean Thinking - Banish Waste and Create Wealth in your Corporation, *Journal of the Operational Research Society*, 48:11, 1148, <https://doi.org/10.1057/palgrave.jors.2600967>.
- Yang, J., Vela, P.A., Teizer, J., and Shi, Z.K. (2014). Vision-Based Crane Tracking for Understanding Construction Activity. *Journal of Computing in Civil Engineering*, 28(1), 103-112, [http://dx.doi.org/10.1061/\(ASCE\)CP.1943-5487.0000242](http://dx.doi.org/10.1061/(ASCE)CP.1943-5487.0000242).
- Zhu, Z., Park, M.W., Koch, C., Soltani, M., Hammad, A., Davari, K. (2016). Predicting movements of onsite workers and mobile equipment for enhancing construction site safety. *Automation in Construction*, 68, 95-101, <https://doi.org/10.1016/j.autcon.2016.04.009>.
- Zoliner, R., Pardowitz, M., Knoop, S., & Dillmann, R. (2005). Towards cognitive robots: Building hierarchical task representations of manipulations from human demonstration. *IEEE Intl. Conference on Robotics and Automation*, 1535-1540.

AUTOMATIC GENERATION OF 3D TERRAIN MODELS FOR DEBRIS FLOW SIMULATION

Takahiro Murase

ChukyoGakuin University, Japan

Kenichi Sugihara

Gifu Keizai University, Japan

Zhenjiang Shen

Kanazawa University, Japan

ABSTRACT: Mountainous countries are prone to natural disasters, especially mass granular flow disasters, such as avalanche and debris flow. Due to the difficulty of direct measurements of the flows, numerical and physical simulations are effective measures to predict and control mass granular flow. In our research, besides carrying out the granular flow simulations along an inclined channel or chute, we use 3D building models placed on the 3D terrain model in which massive moving elements are added for flow simulations. However, enormous time and labor must be needed to manually create these 3D models using 3D modelling software such as 3ds Max or SketchUp. Our contribution is to automate these laborious steps by proposing a GIS (Geographic Information System) and CG integrated system which automatically generates dynamic 3D building models, based on contour polygons of a digital map. The proposed system succeeded in automatically generating a 3D terrain model from a key contour line by straight skeleton computation. The system can perform a physical simulation using a more realistic environment, such as an automatically generated 3D building model placed on a 3D terrain model, and mass granular flow based on Newtonian mechanics. The construction of 'dynamic 3D building models' requires that 3D building models are created being made up of the building parts for dynamic simulation. The moving building parts simulates the dynamic motion such as the collapse of 3D building models hit by a debris flow. In our proposal, contribution to knowledge is that computer geometry such as straight skeleton computation and polygon partitioning are applied to automatically creating 3D terrain models and dynamic 3D building models.

KEYWORDS: 3D terrain model, automatic generation, granular flow simulation, 3D building model, building collapse simulation, straight skeleton.

1. INTRODUCTION

Mountainous countries are prone to natural disasters triggered by a heavy rainfall and an earthquake, such as landslides, rockfalls, deep-seated slope failures, mud flows and debris flows. Due to the difficulty of direct measurements of these flows, numerical and physical simulations are effective measures to predict and control simulating mass granular or debris flow (Tao Zhao 2011). Furthermore, the topography plays an important role in controlling the post failure motion of granular or debris materials (Teufelsbauer 2011). In our research, the topography of a 2D map, i.e., contour lines are converted into a realistic 3D terrain model with inner structure; geological formations or strata. The contour lines are generated from a key contour surrounding a hill or mountain. The proposed system performs a physical simulation using a more realistic environment, such as an automatically generated 3D building model placed on a 3D terrain model with inner structure, and mass debris flow based on Newtonian mechanics. The construction of 'dynamic 3D building models' first requires that 3D terrain models are modified for land formation and site preparation, then 3D building models can be put on these sites. In this case, if 3D terrain models can have inner structure, i.e., strata, then mass granular flow simulations can be implemented in more realistically. However, enormous time and labor must be expended to manually create these 3D models, using 3D modelling software such as 3ds Max or SketchUp. In order to automate laborious steps, we are proposing a GIS (Geographic Information System) and CG integrated system for automatically generating 3D building models, based on contour polygons of a digital map (Sugihara 2011, 2019). In our research, key contour lines are drawn and given a certain elevation, and then the faces connecting key contours are automatically formed, using the straight skeleton computation defined by a continuous shrinking process. In our proposal, based on key contour polygons, the faces connecting key contours are automatically formed with massive elements for dynamic simulation. Furthermore, in our proposal, 3D building models are automatically created being made up of the building parts for dynamic simulation. The moving building parts simulates the dynamic motion such as the

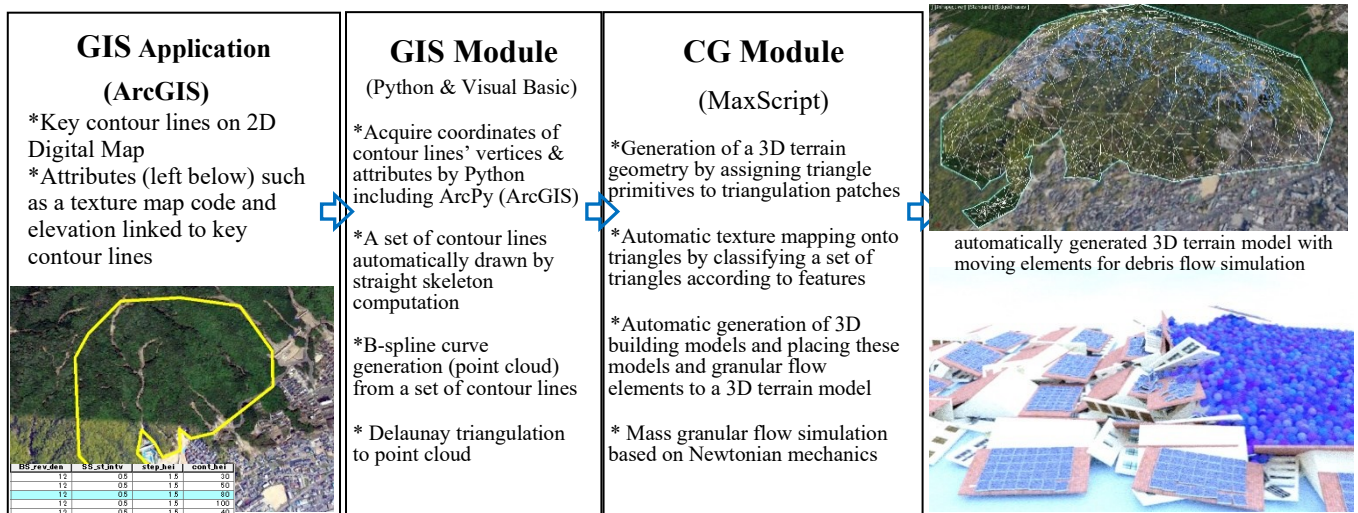


Fig. 1: Pipeline of mass granular flow simulation with realistic 3D models automatically generated

collapse of 3D building models hit by a debris flow as shown in Fig.1 right.

The uniqueness of our system is the simulation of mass granular flow applied to automatically generated dynamic 3D building models built on a 3D terrain model with layers of massive dynamic elements. In the proposed 3D model-based simulation, any formation of mass granular or fragmented rocks layout is possible, depending on 3D terrain models and what kind of flow simulation will be implemented, such as landslides, rockfalls, deep-seated slope failures, mud flows and debris flows.

2. RELATED WORK

Since 3D urban models including 3D building models are important information infrastructure that can be utilized in several fields, the researches on creations of 3D urban models are in full swing. Various types of technologies, ranging from computer vision, computer graphics, photogrammetry, and remote sensing, have been proposed and developed for creating 3D urban models. Procedural modelling is an effective technique to create 3D models from sets of rules such as L-systems, fractals, and generative modelling language (Parish et al. 2001). Müller et al. (2006) have created an archaeological site of Pompeii and a suburbia model of Beverly Hills by using a shape grammar that provides a computational approach to the generation of designs. They import data from a GIS database and try to classify imported mass models as basic shapes in their shape vocabulary. If this is not possible, they use a general extruded footprint together with a general roof obtained by the straight skeleton computation defined by a continuous shrinking process (Aichholzer et al. 1995).

By using the straight skeleton, Kelly et al. (2011) present a user interface for the exterior of architectural models to interactively specify procedural extrusions, a sweep plane algorithm to compute a two-manifold architectural surface.

More recently, image-based capturing and rendering techniques, together with procedural modelling approaches, have been developed that allow buildings to be quickly generated and rendered realistically at interactive rates. Bekins et al. (2005) exploit building features taken from real-world capture scenes. Their interactive system subdivides and groups the features into feature regions that can be rearranged to texture a new model in the style of the original. The redundancy found in architecture is used to derive procedural rules describing the organization of the original building, which can then be used to automate the subdivision and texturing of a new building. This redundancy can also be used to automatically fill occluded and poorly sampled areas of the image set.

Aliaga et al. (2007) extend the technique to inverse procedural modelling of buildings and they describe how to use an extracted repertoire of building grammars to facilitate the visualization and modification of architectural structures. They present an interactive system that enables both creating new buildings in the style of others and modifying existing buildings in a quick manner.

Vanega et al. (2010) interactively reconstruct 3D building models with the grammar for representing changes in building geometry that approximately follow the Manhattan-world (MW) assumption which states there is a predominance of three mutually orthogonal directions in the scene. They say automatic approaches using laser-

scans or LIDAR data, combined with aerial imagery or ground-level images, suffering from one or all of low-resolution sampling, robustness, and missing surfaces. One way to improve quality or automation is to incorporate assumptions about the buildings such as MW assumption.

Jianxiong (2014) presents a 3D reconstruction and visualization system to automatically produce clean and well-regularized texture-mapped 3D models for large indoor scenes, from ground-level photographs and 3D laser points. The key component is a new algorithm called 'Inverse CSG' for reconstructing a scene in a Constructive Solid Geometry (CSG) representation consisting of volumetric primitives, which imposes regularization constraints to exploit structural regularities. However, with the lack of ground-truth data preventing them from conducting quantitative reconstruction accuracy evaluations, they have to manually overlay their model with a floor plan image.

By these interactive modelling, 3D building models with plausible detailed façade can be achieved. However, the limitation of these modelling is the large amount of user interaction involved (Nianjuan et al. 2009). When creating 3D urban models for urban planning or facilitating public involvement, 3D urban models should cover lots of citizens' and stakeholders' buildings involved. This means that it will take an enormous time and labor to model a 3D urban model with hundreds of building.

Thus, the GIS and CG integrated system that automatically generates 3D building models immediately is proposed, and the generated 3D building models that constitute 3D urban models are approximate geometric 3D building models that citizens and stakeholder can recognize as their future residence or real-world building.

In our research, using the straight skeleton computation, a 3D terrain model is also automatically generated, which will be used for a 3D town site prepared and developed among hilly area shown in Fig.1 right. Since the planning 3D terrain model will be developed in future according to the disaster prevention planning map, and does not exist now, it cannot be created by using the computer vision related technologies.

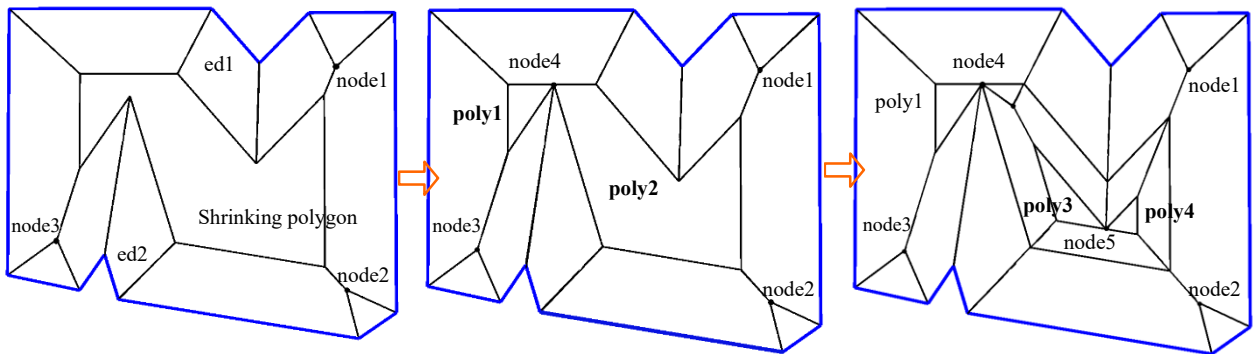
The CAD and GIS software, e.g., AutoCAD Civil 3D (Autodesk) and ArcGIS (Esri) can also create 3D terrain models, and map contour lines. These software assume that there exists a 2D map in which every point on the map are associated with elevation data, and depending on the elevation of the points, these software can create 3D terrain models and draw contour lines of equal elevation. Usually, every point in the 2D map are displayed in different colors or brightness, depending on the elevation of the point. Hence, if a planning map has no elevation data in it, these software cannot draw the contour lines. In our proposal, based on manually drawn key contour polygons associated with an elevation data, straight skeleton computation is performed to the contour polygon, and then the straight skeleton splits the key contour polygon into monotone polygons (faces) which are connecting key contours (Fig.3(c)), and finally 3D terrain models are created. The contour lines of equal elevation can be automatically drawn, based on the connecting faces that form a 3D terrain model.

Also, by CAD and GIS software, contour lines can be drawn by interpolation between a pair of corresponding contour lines, which are assumed be topologically the same contour lines. Many contour lines will be interpolated between many pairs of points on the corresponding contour lines. However, contour lines cannot be drawn by this interpolation between topologically changing contours. In our proposal by straight skeleton computation, when one shrinking polygon is divided into two polygons, the intersection point of these two polygons can be obtained as the point located in the same distance from two edges incident to the reflex vertex and the intersected edge (see Fig.3(b),3(d)). In detail, this intersection is calculated as the intersection of two angular bisectors: one from the reflex vertex and the other bisector between the intersected edge and one of two edges incident to the reflex vertex (see Fig.3(d)). Thus, the contour lines are formed even between topologically different contours.

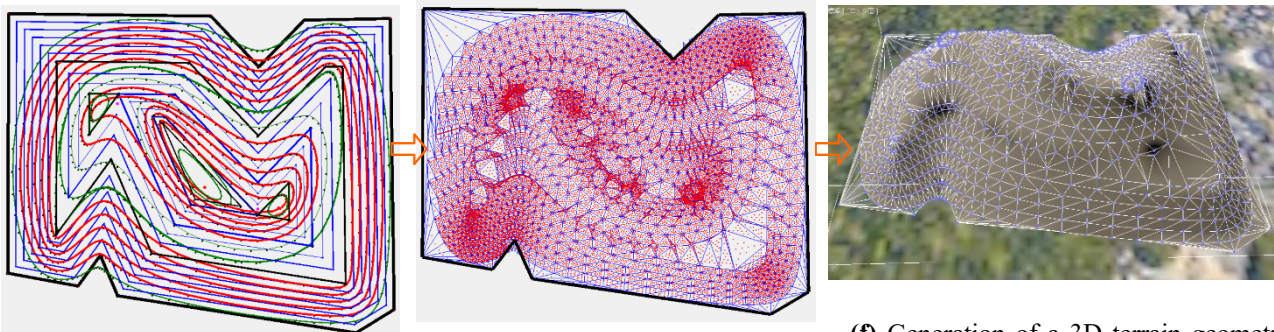
In our research the straight skeleton computation is used for creating the faces connecting main (key) contours (see Fig.3(c)) which are given an elevation. Based on the connecting faces, 3D terrain models are generated, and then 3D house models are placed on these prepared sites. Our methodology saves the laborious steps of drawing contour lines.

3. PIPELINE OF AUTOMATIC GENERATION

As the pipeline of automatic generation is shown in Fig.1, the source of 3D models is a digital map that contains key contour lines and building polygons. The key contour lines are for the automatic generation of 3D terrain models and building polygons are for 3D building models. The digital maps are stored and administrated by GIS application (ArcGIS, ESRI Inc.). The maps are preprocessed at the GIS module, and then the CG module finally



(a) Shrinking polygon just before a *split* event. Edge events give rise to node1~node3
 (b) *Split* event happens and the polygon is split into two polygons; poly1 and poly2.
 (c) *Split* event happens again and the polygon is split into two triangles; poly3 and poly4.



(d) Polygons shrinking at the constant speed; Polygons (blue) at *Split* event. B-Spline curves (red) from these polygons
 (e) B-Spline curves from these polygons. Delaunay triangulation to points on B-spline curves
 (f) Generation of a 3D terrain geometry by assigning triangle primitives to triangulation patches. Automatic texture mapping onto triangles

Fig.2: Automatic generation process of a 3D terrain model by straight skeleton computation; Polygons shrinking at the constant speed; Polygons at Split and Edge event; B-Spline curves; Delaunay triangulation; 3D terrain model

generates the 3D building model. The knowledge-based system is proposed for generating 3D terrain model by linking the key contour line to information from domain specific knowledge in GIS maps; the attributes data such as the elevation, features and control point density of B-spline curve.

As shown in Fig.1 & 2, preprocessing at the GIS module includes the procedures as follows:

- (1) Find out the direct parent contour and equivalent contour between which “me” contour to create connecting faces.
- (2) Calculate the shortest receding distance at which an *Edge* event will happen.
- (3) Check if a *Split* event happens until an *Edge* event will happen while shrinking the polygon shape. If a *Split* event happens, then the polygon is divided into two polygons, which will be active polygons to be checked (Fig.2(a), 2(b)).
- (4) If a *Split* event does not happen during shrinking, then an *Edge* event will happen and the polygon’s topology will be changed to be an active polygon to be checked.
- (5) The shrinking process continues until all active polygons are shrunk into triangles which finally converge to a point (Fig.2(c)).
- (6) Classify the converge points (nodes) according to original edges to which the points belong.
- (7) An original polygon will be divided into several monotone polygons (faces) (Fig.3(c)).
- (8) Based on these faces, points of contour lines of equal elevation are generated (Fig.2(d) & Fig.3(e)).
- (9) From contour line points, B-spline curve are formed for smooth map contours depending on the control point density (Fig.2(d) & Fig.3(e)).
- (10) The delaunay triangulation of B-spline curve points (Fig.2(e) & Fig.3(f))
- (11) Convert delaunay triangulation data to fit for the export format of MAXScript

As shown in Fig.1, the CG module receives the pre-processed data that the GIS module exports, generating 3D terrain models. The CG module follows these steps: (1) Generation of a 3D terrain geometry by assigning triangle primitives to triangulation patches (Fig.2(f) & Fig.4). (2) Automatic texture mapping onto triangles by classifying a set of triangles according to features such as top flat area, slope, flat site, slackly inclined site, and steep incline site. (3) Automatic generation of 3D building models and placing these models and granular flow elements to a 3D terrain model for mass granular flow simulation based on Newtonian mechanics (Fig.1 right & Fig.8).

CG module has been developed using MAXScript that controls 3D CG software (3ds MAX, Autodesk Inc).

4. STRAIGHT SKELETON COMPUTATION

As shown in Fig.3 below, how the faces connecting key contours are formed from key contour lines is as follows. In most cases, the map contour lines are receded when the altitude increases. If a receded map contour line is crossed by itself at a certain height, then a contour line or a contour polygon is divided into two or more contour polygons. In this way, a contour polygon will change topologically during the receding process. If a hill with two peaks is surrounded by one contour polygon, then one polygon will be divided into two polygons as the altitudes increases. In these cases, the polygon has to perform crossing detection with itself since the polygon reduces its size gradually. In this case, a straight skeleton or medial axis computation is quite useful for crossing detection and shape reduction while the polygon is shrinking.

Aichholzer et al. (1995) introduced the straight skeleton defined as the union of the pieces of angular bisectors traced out by polygon vertices during a continuous shrinking process in which edges of the polygon move inward, parallel to themselves at a constant speed. The straight skeleton is unexpectedly applied to constructing general shaped roofs based on any simple building polygon, regardless of their being rectilinear or not.

As shrinking process shown in Fig.2 & Fig.3, each vertex of the polygon moves along the angular bisector of its incident edges. This situation continues until the boundary change topologically. According to Aichholzer et al. (1995), there are two possible types of changes:

- (1) *Edge event*: An edge shrinks to zero, making its neighboring edges adjacent now.
- (2) *Split event*: An edge is split, i.e., a reflex vertex runs into this edge, thus splitting the whole polygon. New adjacencies occur between the split edge and each of the two edges incident to the reflex vertex.

A reflex vertex is a vertex whose internal angle is greater than 180 degrees.

All edge lengths of the polygon do not always decrease during the shrinking process. Some edge lengths of a concave polygon will increase. For example, as shown by 'ed1' and 'ed2' in Fig.2(a), the edges incident to a reflex vertex will grow in length. If the sum of the internal angles of two vertices incident to an edge is more than 360

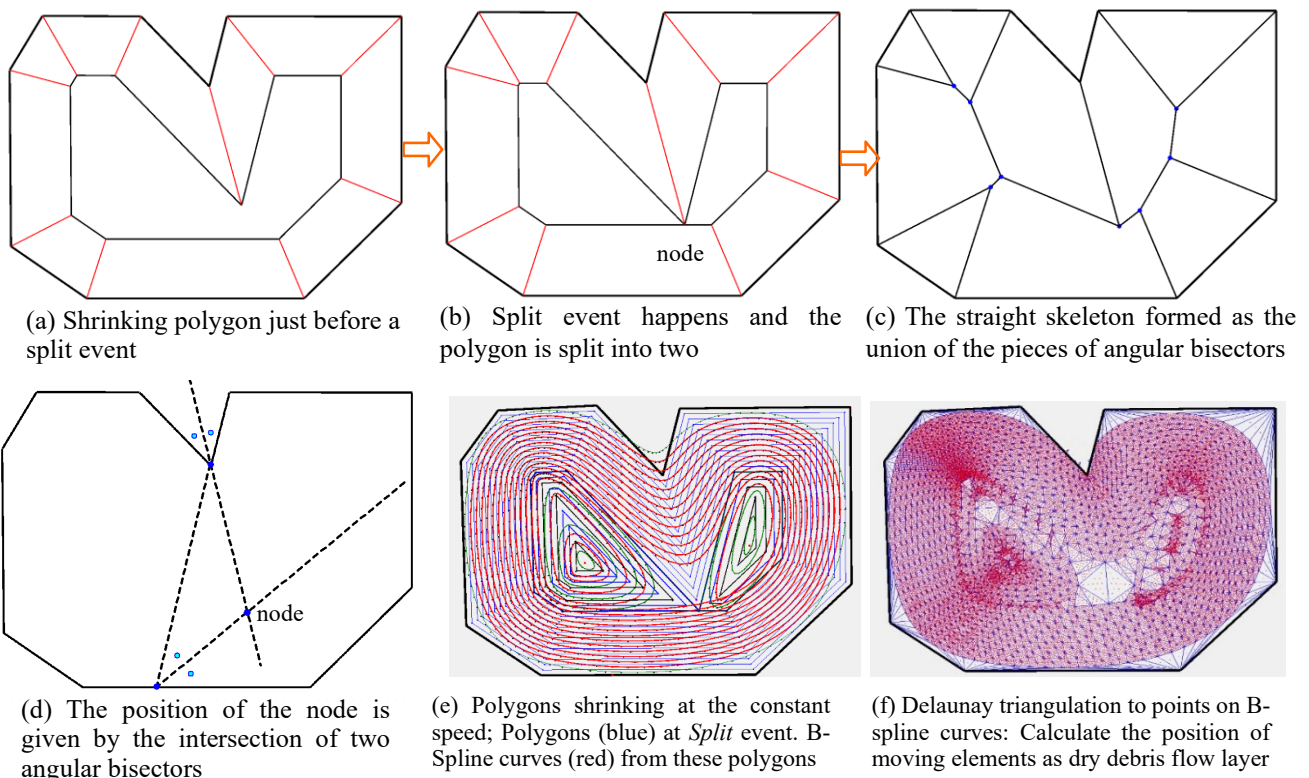


Fig.3: How a split event happens, and how the position of the node is calculated; Polygons shrinking at the constant speed; Polygons at Split and Edge event; B-Spline curves; Delaunay triangulation; moving elements position

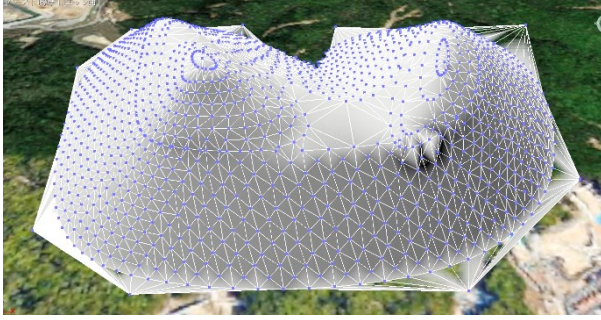


Fig.4: Generation of a 3D terrain geometry by assigning triangle primitives to triangulation patches

degrees, then the length of the edge increases, otherwise the edge will be shrunk to a point (node). Shrinking procedure is uniquely determined by the distance \mathbf{d}_{shri} between the two edges of before and after shrinking procedure. The distance $e_{\mathbf{d}_{\text{shri}}}$ is the \mathbf{d}_{shri} when an *edge* event happens in the shrinking process. $e_{\mathbf{d}_{\text{shri}}}$ for the edge (ed_i) is calculated by numerical formula (1)

$$e_{\mathbf{d}_{\text{shri}}} = \frac{L_i}{(\cot(0.5 * \theta_i) + \cot(0.5 * \theta_{i+1}))} \quad (1)$$

where L_i is the length of ed_i , and θ_i & θ_{i+1} are internal angles of vertices incident to ed_i .

When $0.5 * \theta_i + 0.5 * \theta_{i+1} < 180$ degrees, i.e. , the sum of the internal angles of two vertices incident to an edge is less than 360 degrees, an *edge* event may happen unless the edge is intersected by an angular bisector from a reflex vertex and a *split* event happens.

Fig.3 show a shrinking process for a non-orthogonal concave polygon: Fig.3(a) shows the polygon just before a *split* event: Fig.3(b) shows the polygon being split into two polygons after a *split* event happens, and nodes by an *edge* event and a *split* event. Fig.3(c) shows the straight skeleton formed as the union of the pieces of angular bisectors. Fig.3(d) shows how a split event happens, and how the position of the node arisen by the split event is calculated. The position of the node is given by the intersection of two angular bisectors: one from the reflex vertex and the other bisector between the intersected edge and one of two edges incident to the reflex vertex. To avoid arithmetic operation error which may occur by ‘division by zero’, one of two edges incident to the reflex vertex that has less dot product will be chosen for the intersection.

Fig.3(e) shows a set of polygons shrinking at the constant interval and B-Spline curves from these polygons. Fig.3(f) shows Delaunay triangulation to points on B-spline curves and the calculated position of moving elements as dry debris flow layer. After the shrinking and events process, Fig.4 finally shows the 3D terrain model automatically generated by assigning triangle primitives to triangulation patches at CG module.

5. GRANULAR FLOW SIMULATION

When the area is hit by debris flow, direct measurements are too dangerous to investigate then. In field investigations, researchers always have to study after the event has taken place. In addition, the stochastic nature of their occurrence and magnitude hampers the collection of detailed data on debris flow (Tao Zhao 2014). Widely used debris flow models are based on the continuum mechanics for 2D shallow flow down gently varying topographies in which the velocity distribution through the depth is ignored. However, these theories are said to be too simplistic to accurately predict the flow dynamics in the vicinity of the obstacle, when there is a sudden change in topography, or when an obstacle is hit by the avalanche (Teufelsbauer 2011). In our research, we create the realistic 3D terrain model in which massive dynamic elements are placed for flow simulations. And, dynamic 3D building models are also automatically built in the virtual space for interactive simulation with massive moving elements.

5.1 Discrete Element Method

Instead of using 2D continuum mechanics for shallow flow simulation, 3D model based on discrete element method (DEM) approach for flow simulation is adopted as a research tool by many other researchers. DEM was introduced in geomechanics by Cundall and Strack (1979), and to investigate the mechanics of rock at the microscopic level, the DEM has been developed rapidly with simulations for rock and soil mechanics, chemical engineering and pharmacy (Tao Zhao 2014). Since snow avalanche and dry debris flow can be regarded as granular flows (Teufelsbauer 2011), DEM provides an ideal tool for modeling such phenomena. In comparison to 2D continuum shallow flow models, the 3D DEM model remains applicable to problems with complex topography.

In DEM simulations, the properties (e.g. position, velocity and contact forces) of a stressed collection of rigid spherical particles are updated at every numerical iteration time step. The translational and rotational displacements

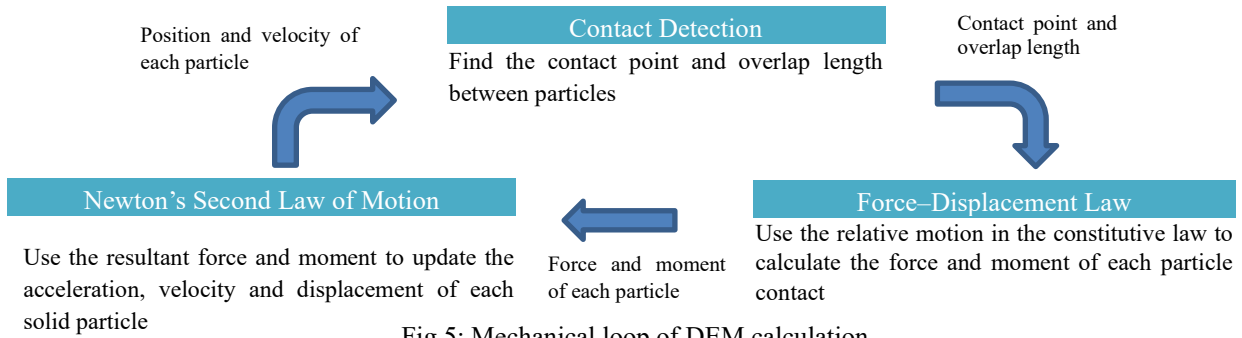


Fig.5: Mechanical loop of DEM calculation

of each particle are obtained by explicitly integrating the governing differential equations based on the Newton's second law of motion, while the contact forces between particles are calculated using well defined force-displacement contact models (Cundall and Strack 1979). In this process, the interactions between particles are monitored at all contacts and the movement of each individual particle is traced. It is assumed that the velocity of each particle is constant within each iteration step. Since the explicit integration technique is used in the DEM calculation, the time step is required to be very small so that stable numerical solutions can be achieved.

Fig.5 above shows the mechanical loop of the DEM calculation. The simulation will start by detecting the contact points between particles. The contact point and the particle overlap distance are then used to calculate the interaction forces via the force-displacement relationships. The resulting contact forces are applied at the center of each particle, causing particles to move. According to the Newton's second law of motion, the particle acceleration, velocity and displacement are updated at the end of each numerical iteration step. This mechanical loop continues until the prescribed total iteration step is reached.

5.2 Simulating Physics by MassFX

We use MassFX tool of 3ds Max (3D CG software) for a dynamic simulation, which allows us to animate objects with various input parameters depending on gravity and physics. The objects such as solid, soft, cloth, or liquid can be defined through parameters setting. MassFX creates animation by simulating real-world physics. The tool is extremely useful to scatter objects such as those displayed in Fig.1 right, or to create action in a particular scene to make it more interesting.

Physical simulation is realized by detecting a collision among objects and calculating impact force through penetration depth between each object's 'physical shape' which is the geometry that MassFX uses in the simulation. For relieving the burden of PC, 'physical shape' will take the form of simplest geometry shape for all moving bodies in the simulation. For physical simulation, the object has to have another shape, i.e., 'physical shape' besides graphical shape (named 'original' in MassFX), both of which are not always the same. A dynamic rigid body must be represented in MassFX with convex physical shapes. To model a concave shape, it will be approximated with a collection of smaller convex shapes. For example, in MassFX tutorial, a bowl which is concave is assigned by a set of convex hulls by 'MassFX Rigid Body modifier'. In our research, debris elements are assumed to be the element of convex shape, i.e., a sphere or regular polytopes, e.g., tetrahedron or octahedron. However, dynamic 3D building models may have parts of concave shape, which are to be decomposed into a collection of convex hulls.

By using MassFX as well as DEM, the dynamic simulation of mass granular flow can be performed with thousands of moving elements (ball). The element in MassFX can have properties such as static friction, dynamic friction, and bounciness. Although governing differential equations are not revealed in MassFX, it can be assumed that elements are following Hooke's force-displacement law, since we observe rebounding behaviors of the overlapped elements. We also find that as the penetration depth between elements increases, the rebounding force increases, too. In DEM simulation, the material

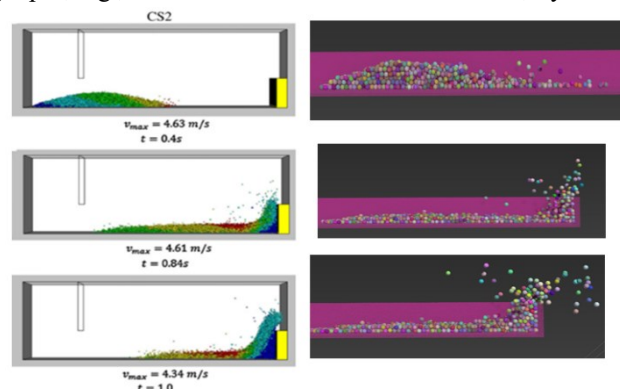


Fig.6: Comparison of granular flow impact behavior between DEM(left) and MassFX (Both cases studies are performed with free ball-wall rotation, free ball-ball rotation)

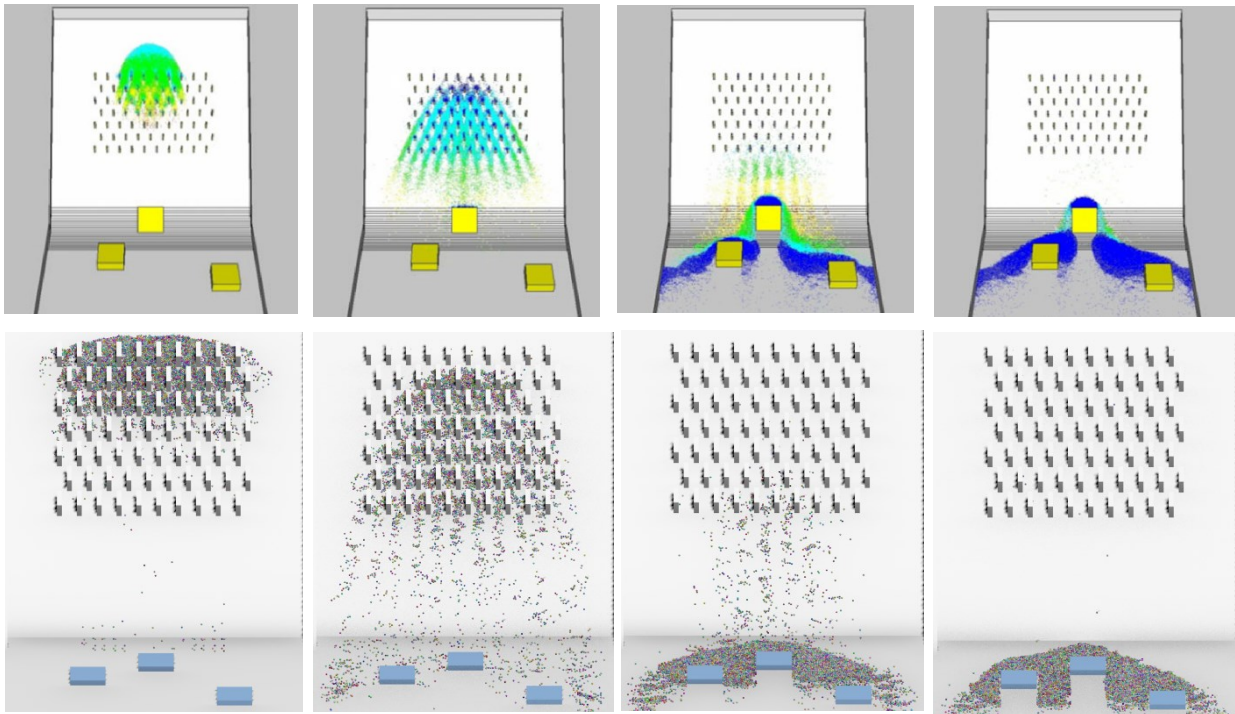


Fig.7: Comparison of granular flow interaction between DEM (up) and MassFX (down) (Snapshot series of the interaction between protection structure matrix and avalanche)

properties of the discrete elements (balls and walls) are characterized by the stiffness and friction. This stiffness is equivalent to the bounciness of MassFX so long as both follow Hooke's force-displacement law.

In DEM research, results of the simulations are compared with experimental data for verification and validation of simulation models. Teufelsbauer (2011) carried out parametric studies to show the effect of model parameters on granular flow, including the run-out distance, deposition pattern, flow pattern, and impact forces against an obstacle. The comparison between numerical simulation and laboratory experiments for different channel inclinations and chute types shows good agreement. They concluded that the comparison of impact forces and flow patterns with laboratory experiments indicates the potential applicability of the presented DEM avalanche model for a wide range of laboratory setups.

In our research, the comparison between DEM numerical simulation and MassFX simulation is executed for the validity of MassFX flow and interactive simulation. Fig.6 shows the comparison of granular flow impact behavior between DEM (Teufelsbauer 2011) and MassFX in which both case studies are performed with free ball-wall rotation, free ball-ball rotation. Fig.7 also shows the comparison of granular flow interaction between DEM (up) and MassFX (down) in which snapshot series of the interaction between protection structure matrix and avalanche.

6. APPLICATION

Here is the example of a 3D terrain model automatically generated by the GIS and 3DCG integrated system. Fig. 8 shows automatic generation process of a 3D terrain model by straight skeleton computation, B-spline curve, and Delaunay triangulation. The key contour polygon manually drawn (Fig. 8(a)) is shrinking at the constant speed. From a series of shrinking polygons, B-spline curves shown in red are formed for smooth map contours. Delaunay triangulation to points on B-spline curves is implemented by GIS module. By CG module, a 3D terrain model is generated by assigning triangle primitives to triangulation meshes, and moving elements are placed on these meshes as a layer for mass granular flow simulation.

For everyone, a 3D urban model is quite effective in understanding what if this alternative town plan is realized, what image of a sustainable town will be. Traditionally, urban planners design the town layout for the future by drawing building polygons, and perhaps contour lines of equal elevation for a 3D terrain model on a digital map. Depending on the building polygons and contour lines, the proposed system automatically generates a 3D building model placed on a 3D terrain model so instantly that it meets the urgent demand to realize another alternative urban planning for sustainable development or disaster prevention.

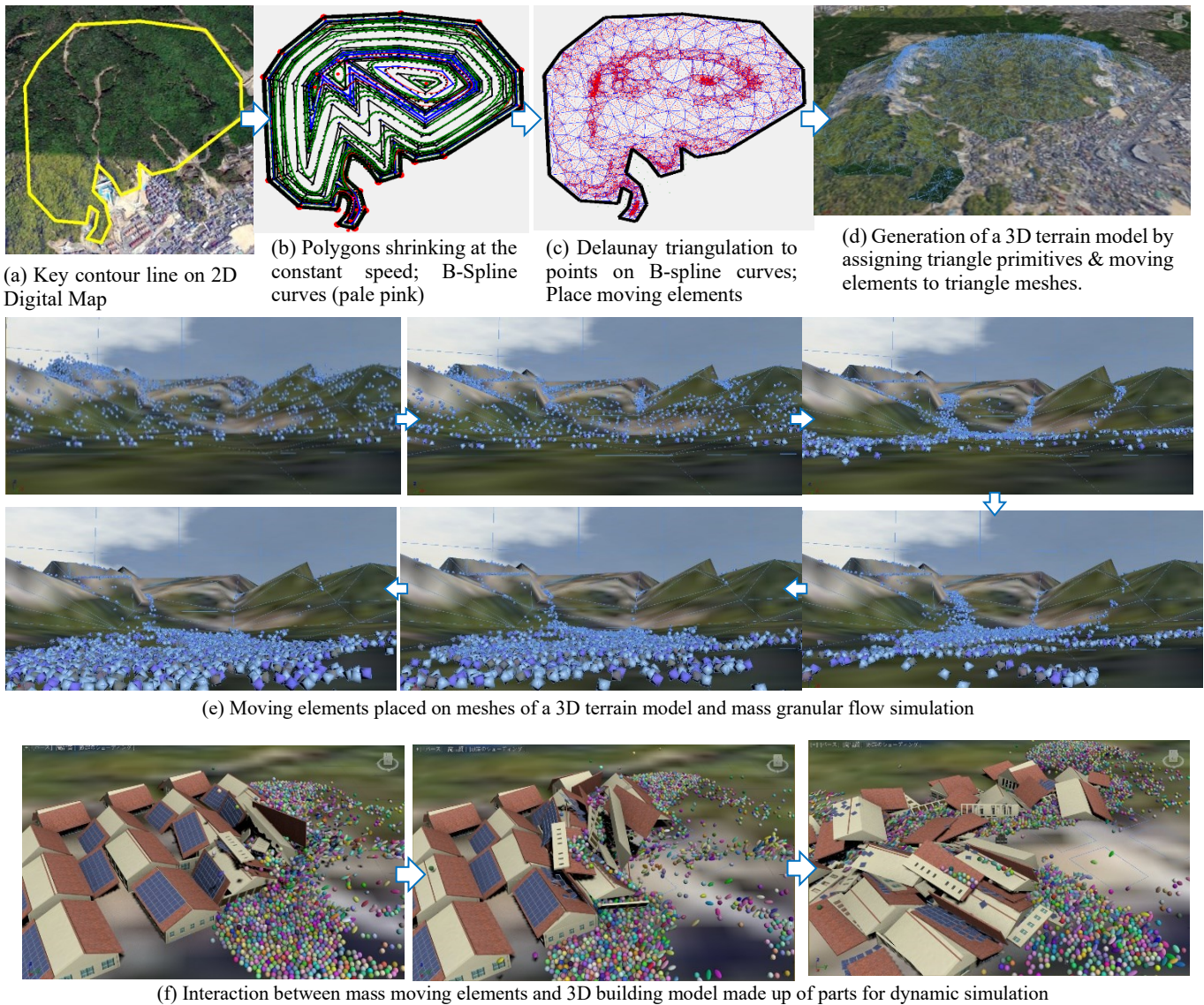


Fig.8: Automatic generation process of a 3D terrain model by straight skeleton computation and mass granular flow simulation, collapse of 3D building models hit by a debris flow

In our proposal, based on key contour lines manually drawn, the faces connecting key contours are formed (Fig.3(c)), and then 3D terrain models are automatically created. The multiple contour lines of equal elevation can be automatically drawn, based on the connecting faces that form a 3D terrain model. In our research the straight skeleton computation is used for forming faces connecting key contours. Based on the automatically drawn map contour lines, 3D terrain models are generated, and then 3D house models are placed on these prepared sites. Our methodology saves the laborious steps of creating 3D terrain models.

For everyone, a 3D terrain model with 3D house models is quite effective in understanding what if houses are hit by debris flow and what if this land development plan is realized or what image of a sustainable town will be. Our contribution is that the proposed system generates a 3D terrain model with 3D house models so quickly that it comes up with another solution for disaster prevention or sustainable development.

7. CONCLUSION

In our research, a collection of contour lines is created by the straight skeleton computation from a key contour line. These contour lines are uniquely decided by the shrinking distance from the original key contour. Fig.2 and Fig.3 show that contour lines are receded inside by the constant speed. In the shrinking process, the topology

remains unchanged until the event (*Split* or *Edge*) occurs. The shrinking distance during the shrinking process when the topology remains the same can be regarded as a ‘shrinking unit distance’.

In order to generate the contour lines at equal intervals, in our system, the shrinking unit distance will be divided by the built-in standard interval, and the number of the contour lines for the unit distance is decided, then the contour lines of equal distance will be drawn. For example, in Fig.2(d), the shrinking distance during the shrinking period when eleven vertices polygon keeps eleven vertices is divided by the standard interval, and ‘five’ contour lines of equal distance are drawn. At the end of the shrinking unit period, two *Edge* events has happened simultaneously, then the vertices number is reduced to nine. As for an *Edge* event, we know the shrinking distance by numerical formula (1). However, as for a *Split* event, the system does not know the shrinking unit distance while shrinking. It gets to know the unit distance when the intersection has been detected between the angular bisector from a reflex vertex and another edge of the polygon. The contour lines of equal distance will be drawn after the split event has happened.

The uniqueness of our system is that the proposed system performs a physical simulation using a more realistic environment shown in Fig.8, such as an automatically generated 3D building model placed on a 3D terrain model, and mass granular flow based on Newtonian mechanics. This is realized by using MassFX of 3ds MAX which provides tools for animating objects to behave as they do in the physical world. In this environment, a 3D terrain model is set to ‘static rigid bodies’, and granular is ‘dynamic rigid bodies’. In the proposed 3D model-based simulation, any distribution or shape of mass granular formation is possible, depending on 3D terrain models and what kind of simulation will be implemented such as landslides, avalanche or debris flow.

The limitation of our work is that the only one key contour generates a 3D terrain model, which prevent the system to form any shape of terrain models. Based on multiple key contours, any shape of terrain models can be created.

ACKNOWLEDGMENTS

This work was funded by JSPS KAKENHI; Grant-in-Aid for Scientific Research (C) Grant Numbers 20K03138, 19K04750, 18K04523.

8. REFERENCES

- Aichholzer O., Aurenhammer F. and Albers D., Gärtner B. (1995). A novel type of skeleton for polygons, *Journal of Universal Computer Science*, 1 (12): 752–761.
- Aliaga G. Daniel, Rosen A. Paul ,and Bekins R. Daniel (2007). Style Grammars for interactive Visualization of Architecture, *Visualization and Computer Graphics, IEEE Transactions on Volume:13*, 786 - 797
- ArcGIS websites. *ArcGIS resources*, <https://pro.arcgis.com/ja/pro-app/tool-reference/3d-analyst/how-contouring-works.htm>
- Autodesk Knowledge Network, *Autodesk AutoCAD Civil 3D*, <https://knowledge.autodesk.com/support/autocad-civil-3d/learn-explore/>
- Bekins R. Daniel ,and Aliaga G. Daniel (2005). Build-by-number: rearranging the real world to visualize novel architectural spaces, *Visualization, VIS 05. IEEE*, 143 – 150.
- Carlos, V. A., Daniel, A. G., andr Bedřich, B. (2010). Building reconstruction using Manhattan-world grammars, *Computer Vision and Pattern Recognition (CVPR)*, IEEE Conference on: 358 – 365
- Cundall PA, Strack ODL (1979). A distinct element model for granular assemblies, *Geotechnique*, 29:47–65
- Nianjuan, Jiang, Ping, Tan, and Loong-Fah, Cheong (2009). Symmetric architecture modeling with a single image, *ACM Transactions on Graphics - TOG*, vol. 28, no. 5
- Pascal Mueller, Peter Wonka, Simon Haegler, Andreas Ulmer, Luc Van Gool. (2006). Procedural modeling of buildings, *ACM Transactions on Graphics* 25, 3, 614–623.

Sugihara, K. and Kikata, J.(2012). Automatic Generation of 3D Building Models from Complicated Building Polygons, *Journal of Computing in Civil Engineering, ASCE*

Sugihara Kenichi (2019). Straight Skeleton Computation Optimized for Roof Model Generation, *WSCG 2019, 27th. International Conference in Central Europe on Computer Graphics, Visualization and Computer Vision 2019*, <https://doi.org/10.24132/CSRN.2019.2901.1.12>, 101–109.

H. Teufelsbauer, Y. Wang, S. P. Pudasaini, R. I. Borja, W. Wu (2011). DEM simulation of impact force exerted by granular flow on rigid structures, *Acta Geotechnica*, DOI 10.1007/s11440-011-0140-9, 6:119–133.

Tao Zhao (2011). Investigation of Landslide-Induced Debris Flows by the DEM and CFD, *A thesis submitted for the degree of Doctor of Philosophy at the University of Oxford*, St Cross College, Oxford, Hilary Term

Tom Kelly, Peter Wonka (2011). Interactive Architectural Modeling with Procedural Extrusions, *ACM Transactions on Graphics (TOG)* 30 (2), 14.

Yoav I. H. Parish, and Pascal Müller (2001). Procedural modeling of cities, *Proceedings of ACM SIGGRAPH 2001*, *ACM Press*, E. Fiume, Ed., New York, 301–308.

Part6. Artificial Intelligence

WEB-BASED CONSTRUCTION COLLABORATION TOOLS: TEXT MINING OF USER PERCEPTIONS

Mahmuda Chowdhury

Faculty of Science Engineering and Built Environment, School of Architecture and the Built Environment, Deakin University, Geelong, Australia

M. Reza Hosseini

Faculty of Science Engineering and Built Environment, School of Architecture and the Built Environment, Deakin University, Geelong, Australia

Igor Martek

Faculty of Science Engineering and Built Environment, School of Architecture and the Built Environment, Deakin University, Geelong, Australia

David John Edwards

Faculty of Computing, Engineering and the Built Environment, Birmingham City University, Birmingham, UK and University of Johannesburg, Johannesburg, South Africa

Tandeep Singh

Faculty of Science Engineering and Built Environment, School of Architecture and the Built Environment, Deakin University, Geelong, Australia

ABSTRACT: *Web-based collaboration tools are an essential part of construction projects because they empower project teams in the coordination and integration of project data and assist organizations in managing construction activities and processes. The uptake of collaboration tools is on the rise, and with it, technological features and applications are evolving. One key attribute is the way in which users interact and engage with these tools. Although extant literature documents the importance of users' perceptions, scant research has sought to understand users' perceptions of existing collaboration tools. Consequently, this cross-sectional study attempts to collate and analyze end-users' perceptions of collaborative tools through quantitative text-mining and content analysis methods. Using users' reviews of six prominent tools, sentiment analysis is conducted revealing 322 of 1,153 reviews were negative, while 804 were positive. Analyzing the content of positive and negative datasets indicate that 'document management', 'reporting features' and 'user-friendliness' are priority features; albeit, these are affected by various shortcomings. Findings also reveal that the nature of projects influence the adoption of different tools. This study adds to the body of knowledge on collaboration technology in a construction context. In practical terms, findings will assist system developers, project managers and vendors on devising plans in the effective adoption of collaborative tools and producing appropriate risk mitigation strategies to deal with any shortfalls.*

KEYWORDS: *Collaboration technology, construction, web-based collaborative tools, text mining, sentiment analysis.*

1. INTRODUCTION

Evidence shows that web-based collaboration tools and associated mobile application implementation are rising; 72% of US construction professionals utilize smartphones at work. Similarly, 63% of construction businesses have implemented cloud-based platforms to improve information access from remote locations ([Kracunas and Kracunas, 2016](#)). Anecdotal evidence suggests that this implementation figure is set to increase. The number of existing collaboration tools varies according to different sources, from 325, 349 or 374 tools ([Crowd, 2018](#), [Softwareadvice, 2018](#)). Along with the number of tools, the ranking of the top tools also varies according to different sources, thus compounding the dilemma of selecting an appropriate tool. Moreover, the inconsistency of tools' ratings and variations in internal methodology results in different decision outcomes.

Previous studies have focused on the: effectiveness of collaboration tools ([East et al., 2008](#)) technological aspects ([Zhang et al., 2017](#)); identification of barriers and frameworks for improvement of collaboration and communication and communication between project teams ([Hosseini et al., 2017](#)). In addition, teamwork improvements via utilizing collaboration tools ([Costa and Tavares, 2012](#)) have also been explored, along with the identification of the antecedents and drivers of collaboration technology adoption. Although previous studies have identified the barriers and challenges with respect to collaboration tools, users' perceptions of collaboration tools have not been considered. Consequently, this research aims to address this gap, through: analyzing the reviews of

six prominent collaboration tools users' reviews; revealing the key features of the tools; and identifying positive and negative attributes. The study contributes to the prevailing body of knowledge by providing a cross sectional snapshot of existing users' perceptions, which will be invaluable in assisting vendors and system developers, as well as digital managers and project leaders of construction projects, in their efforts to augment performance.

2. BACKGROUND

Web-based collaboration tools have different features and applications to assist in the coordination of business processes and enable collaborative workflow, data access, team and office integration ([Capterra, 2020](#)). Project management and customer management functionality along with accounting, scheduling, and portfolio management services often incorporated in these tools. The benefits of web-based collaboration tools are discussed in the following section.

Document management applications of web-based collaboration tools assist in storing, organizing, and managing documents digitally within construction projects ([Adriaanse et al., 2010](#)). Moreover, effective information management and exchange ([Comiskey et al., 2017](#)) can be achieved through collaboration tools. Working as a central repository for project information, web-based collaboration tools facilitate the sharing of resources between geographically dispersed teams while also enhancing communication ([Charalambous et al., 2017](#)). Moreover, inter-organizational cooperation, coordination, and communication can be supported by product modelling application of tools, such as 3D and 4D modelling, and building information modelling ([Adriaanse et al., 2010](#)). As web-based collaboration tools enhance the overall communication, team effectiveness will be improved since team effectiveness is highly dependent on the quality of communication, and the quality of information and data exchange ([Hosseini et al., 2017](#)). Furthermore, team members can access only assigned areas and information ([Comiskey et al., 2017](#)), resulting in improved data privacy. Consequently, improved information flow, elimination of waste within construction projects ([Charalambous et al., 2017](#)), and real-time visibility of project life cycle ([Capterra, 2020](#)) results in improved collaboration ([Ma et al., 2018](#)).

Technical advancement in cloud computing and the web have fast-tracked rapid growth of globally dispersed project teams on construction projects ([Hosseini et al., 2018a](#)). Monitoring and recording the progress of tasks, managing the flow of documents and information can be done by workflow management application ([Adriaanse et al., 2010](#)) of web-based tools. Consistency levels, efficiency, coordination, and quality improves with best practices in data management ([Comiskey et al., 2017](#)). BIM and digital technologies foster the integration of activities and strengthen the management of projects, data accuracy and information management ([East et al., 2008](#)). In brief, web-based collaboration tools enhance collaboration through better management of workflow. Collaboration tools can integrate with BIM to address data sharing and data processing requirements ([Charalambous et al., 2017](#)). The number of web-based collaboration tools in the market ranges from 200 to 375, according to various software reviewing online platforms ([Crowd, 2018](#), [FinancesOnline, 2018](#)). This trend illustrates that over time, the number of tools is increasing, and the features of tools are dynamically shifting to accommodate new user requirements and technological advancement.

Despite the extensive availability of collaboration tools, the problems regarding collaboration in construction remains an ongoing challenge ([Mignone et al., 2016](#)). Many studies of collaboration tools focus on various technological aspects. For instance, web-based semantic technology and applications, mobile social media technologies, different systems categorization ([Abanda et al., 2015](#)), collaboration tools validation ([East et al., 2008](#)) and interoperability issues, have been explored. According to [Oraee et al. \(2017\)](#), collaboration in construction has been investigated mostly through the technology-oriented lens. Another group of researchers emphasized the interrelation of collaboration tools, and project teams and networks ([Oraee et al., 2017](#), [Papadonikolaki et al., 2019](#)); collaboration tools adaptation, implementation, and barriers; collaboration tools and education ([Comiskey et al., 2017](#)).

3. RESEARCH METHODS

The study objectives necessitate exploring the end-users' perceptions of tools by direct quantitative analysis of reviews to identify patterns and latent connections of the different attributes. The research relies on analysis data related to the most common collaboration tools. The natural human language of the reviews is unstructured and required a method that will process the dataset to reveal patterns. Text mining can handle a large number of unstructured texts to reveal underlying patterns and trends. Furthermore, qualitative content analysis is conducted to investigate the dataset. Text mining is a remedial solution to uncover knowledge from collections of unstructured text. An increasing number of online reviews are posted daily on the internet which is a great source of data for

making management decisions (Bi et al., 2019). For this present study, text mining analysis was conducted using RapidMiner Studio 7.5, which is an open-source data mining and business analytics software solution. After conducting the sentiment analysis, the positive and negative datasets were further analyzed and processed to identify the term frequency.

Five million, three hundred thousand users have been identified as using at least one of the collaboration tools. This indicates the importance of collaboration tools as well as the extent of usage. According to pertinent websites, ranking for the top ten tools is based either on customer number, social presence, price, ratings, or internally developed ranking algorithm (Crowd, 2018, FinancesOnline, 2018). Web-based construction collaboration tool listing websites like Capterra focus on a sponsor, highest-rated, and most reviews to rank the tools (Capterra, 2018). FinancesOnline ranking system, on the other hand, is based on an internally developed SmartScore™ algorithm which considers functionalities, collaboration features, customization capabilities, and available integrations, for ranking the tools. Based on the ranking of FinancesOnline, the top six tools were CoConstruct, PlanGrid, Autodesk BIM 360, Procore, e-builder, and Aconex. The ranking contained within the website considered the collaboration features of the tools. For this reason, the aforementioned six tools were considered for analyzing users' reviews. In extracting the reviews, another review website 'Business Software Reviews from Software Advice™', was considered and accessed on 15.12.2018 to collect reviewers data. This website accumulated reviews from a variety of sources (Softwareadvice, 2018).

To create the data set, a web crawling method was implemented. The review website 'Business Software Reviews from Software Advice™', was accessed on 15.12.2018 to collect data of reviewers. Around 200 reviews for each tool resulted in 1,153 data set of reviews for the most popular six tools. Outwit hub (which is an open-data web scrapping tool) was implemented to extract data. Source code was utilized to collect the multiple web pages review data information. The data set was further filtered, merged and organized in a spreadsheet containing three columns: "collaboration tools name", "Company Size", and "Reviews". A total of 1,153 Reviews of six prominent tools were prepared for further analysis.

Unstructured data can be processed using one of the available operators for sentiment analysis methods in RapidMiner, like Rosette (Arianto et al., 2017). Having textual data as input, Rosette can return sentiment categories associated with an entire document, or for individual passages within a larger body of the text. Rosette relies on natural language processing (NLP) techniques for automated recognition and understanding of the view and opinions expressed in a human-generated text. It associates the subjective opinion embedded in a given text with a label: positive, negative, or neutral. The 1,153 reviews were analyzed in RapidMiner Studio 7.5 utilizing Rosette extension. The qualitative content analysis determines the specific word frequency appearing in a text and can assist in describing the meaning of the textual narrative. Content analysis has been defined as "a research technique for making replicable and valid inferences from text context of use" (Yu et al., 2006). After conducting quantitative analysis through text mining, content analysis was adopted to further investigate the most frequently appearing words, connections and association, within the positive and negative data set.

4. FROM REVIEWS TO FINDINGS

4.1 Sentiment analysis

Of the 1,153 data sample frame, 379 cases represent large companies, 353 belong to small-sized companies, 205 from medium-sized companies, with only 16 of the reviewers belong to micro-companies, as illustrated in Figure 1. This sample represents a reasonable balance of participants and coverage of all categories of major users of collaboration tools in the construction industry. Specifically, micro-companies are not typical users of collaboration tools. Among the reviews, 804 were positive about the collaboration tools, only 26 cases were neutral, and 322 were negative, as indicated in Figure 2.

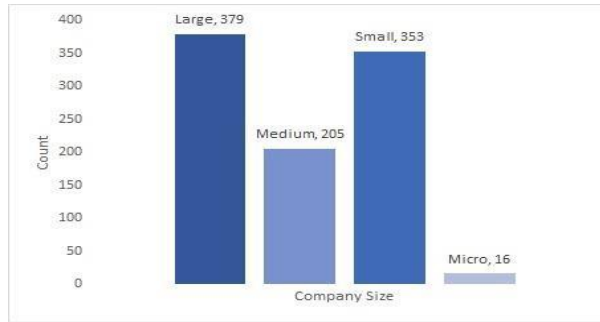


Figure 1: Distribution of company size among the reviewers.

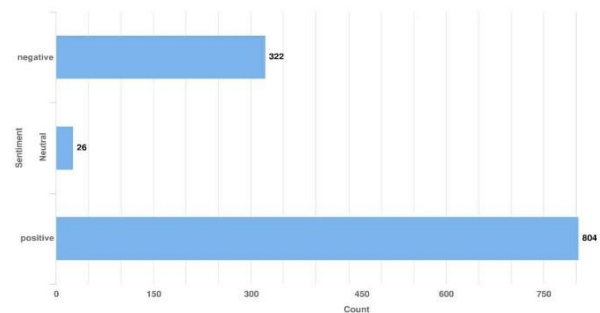


Figure 2: Sentiment analysis result of dataset.

4.2 Text mining (term frequency)

Term Document Matrix (TDM) is a procedure that converts textual data into a TDM (Hosseini et al., 2018b). Words are operated into “tokens” as text mining algorithms treat words in a sentence as unrelated objects (Hosseini et al., 2018b). According to Hosseini et al., 2018, the tokenizing process is to convert text into bags of tokens and tokens create the TDM, in which each token is an attribute and each document is a case (Hosseini et al., 2018b). Figure 3 indicated the steps of TDM creation followed by Filtering stopwords which removed common terms for instance “a”, “and”, “etc.”

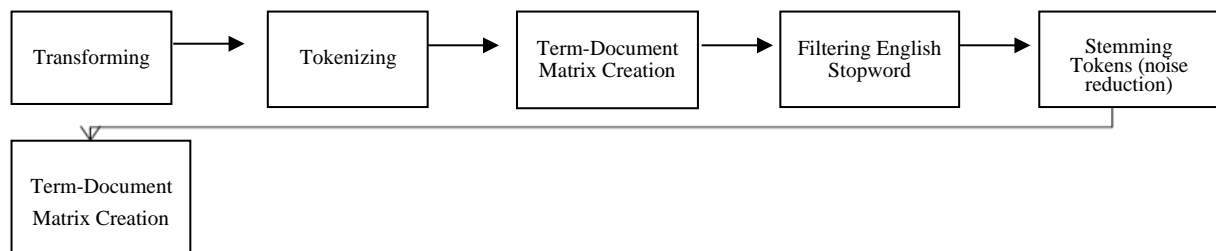


Figure 3: Text Mining Process

Large complex data sets of textual documents contain a substantial amount of irrelevant information (Ertek et al., 2014). A frequency-based feature application has been utilized to create meaningful tokens and to remove noise for this dataset. This resulted in a document containing ‘total occurrences’ and ‘document occurrences’ of the most frequent words both in both the positive and negative data sets.

4.3 Content analysis of positive dataset

Following the sentiment analysis, the frequency of words that appeared most were thematically grouped into a positive and negative data set (refer to Tables 1 and 2 respectively). For the large positive data set, a list of 90 words that frequently appeared have been identified. Of the 90 words identified, those that appeared more than 150 times are provided in Table 1, along with total number of occurrences and document occurrences.

Table 1: List of total occurrence and document occurrence of frequently appeared word in positive data set

Word	Total occurrence	Document occurrence	Associated concepts
Project	543	321	Project management tool, construction project management tool, project delivery, integrated project, project management coordination, project need, project team, project coordinator, clicking between projects, project-related documents, project organization, Accessibility of project information, project stakeholders and total control over projects.
Great	414	289	Great software, great tool, great streamlines communication, great overall experience, great way to document progress, overall performance great, bidding is great, great customer service, training videos great, great for collaborating, great experience, great for workflow, great for keeping track of communication and great time-saving.
Software	409	255	Estimation software, learning, competitors, convenient, software mobile app, great and integration software, building software, software user friendly, construction management software, accounting software and cloud-based software.
Document	333	182	Contract documents, reference documents, drawing documents, document management, document control, document traceability, communication document, event history document, store approved documents, upload documents, organize documents, documentation, accessibility of documents and duplicate documents.
Manage	269	193	Cloud-based management, better time management, better drawing control management, documentary management and workflow, construction management, document register management, project management, management features, process manage and manage plans.
Construct	251	170	Construction document, construction work, construction jobs, construction management, construction process, construction software, type of construction, pre-construction, construction manager and constructive reviews from the subcontractor.
Custom	223	158	Customer service, customization and customize, allow more customization, tool needs to be customizable without Admin rights, customer services are very accommodating and Customer support
Feature	216	166	Workflow feature, collaborate & calculation feature, navigate feature, meeting minutes feature, subcontractor features, features in computing estimation, features easy to learn, tracking features, reporting features, edit features, scheduling features and sync features.
Inform	183	139	Information, informed, transfer information, project information, organize information, relevant information, sharing information, building information, informative training, consolidate information, store information, filtering and sorting information, customize information and real-time information.
Product	181	137	Overall product, similar & great product, productivity, resultant & software product, tracking productivity, constantly improving product, Recommendations with this product, Great for our production team, product training, using a product, product data and product knowledge.
Field	161	116	Magnificent Field, Field Reports, construction field, Field Employees, field superintendents, office-field-client, and field workers have instant access, schedule in the field, reduce field mistakes. a field on the dashboard and smartest field tracking program.
System	159	106	Project Management System, great & different systems, document management system, time clock system, PO system, everything in one system, project delivery system and Strong Accounting System.

Easy use	158	143	Ease to use, easy to access, Easy to use great Customer Service, get up and running right away, but complete, estimating and budgeting option, presentable to clients and Excellent and easy to use Customer support.
Access	152	119	Access current drawings, access from any device, internet access, access from anywhere, easily accessible, 1 cloud base and Document access.
Process	151	106	Project management process, dispute resolution process, construction process, closeout process, learn the process, Constant learning process, guide me through the process, process solution and Integrated processes

4.4 Content analysis of negative dataset

After sentiment analysis, the negative and positive data set was investigated through text mining and the frequency of total words and document occurrences of words was created. In the negative data set, list words like ‘great’, ‘builder’ and ‘construct’ were omitted, as they do not exhibit any meaningful result. Although a total of 81 frequently appearing words were noted, only words that had more than 40 total occurrences were selected for content analysis. Findings of the most frequently appearing words are summarized as Table 2.

Table 2: List of total occurrence and document occurrence of words in negative dataset.

Word	Total occurrence	Document occurrence	Associated concepts
Project	251	137	Project management, large-size projects, project documents, project manager, manage an entire project and tracking project.
Document	191	98	Document tracking, edit documents, poor documentation, critical construction documents, company’s documentation, project documents, field documentation side and document control manager.
Software	151	112	Project management software, powerful software, accounting software, software is expensive, easy to use software, improving the software and software was more user friendly
Manage	109	73	Management software, construction management, project management, monitoring and properly manage, manage an entire project, how we managed our business, document management and manage appointments.
Report	99	60	Custom report tool, customization reports, put a daily report together, inspection reports, reports to be exported, ability to utilize BI for reporting, many types of reports, project report field and setting up reports.
Feature	77	56	Features are difficult to learn, features not working, features they promise some features require internet connection, feature that adds material to overall cost, some additional features, report features and few features that it doesn’t have.
Access	70	54	Database accessible, allows access to important information, peak hours can limit access, no internet ...no access, easily accessible tools that are used daily, has access to every document at any time, have access to all project documents, access from different software and easy access to projects information.
Process	68	40	Slow the process down, process need work, streamlining process, selection process, construction process, process integration, billing process, business process, can be slow to response and process and not a smooth process.
Custom	67	49	Customer support customers, custom build, custom report tool, interaction and customization, customer service, customer-centric, customer interaction and customer portal.
Field	66	47	Project management field use in the field and the office, field documentation, field team, some data fields not available for setting up reports, custom fields, and not certain what fields to fill out.
System	66	42	System overloads, system navigate, overall system, have duplicity in the system, data access can be challenging for a project-based system, difficult to learn the system and reporting system.
Upload	62	40	Re uploaded, ability to upload, documents upload, mass upload product specs, need more flexibility for folders and uploading, only single photo upload and uploaded file difficult to find.

Allow	61	51	Allow to store, more level of users allow different pricing structures, allow mark ability, allow to tack as-built work, allow many users to work together, the workflow does not allow multiple comments per sheets and doesn't allow for flush photography.
Update	56	38	Update construction documents, design updates, complicated to update, updated drawings, regular updates and mobile update.
Inform	54	40	Centralized information, project information, required information, extract some analytical information is not available, crucial to transmit accurate information and not able to access or manipulate all the information via an app,
Function	48	42	New functionalities, drag and drop functionality, project functions and details, difficult to produce a report with functions, crash issue fixed functional but limited ability, too many functions, need to apply similar functions, level of functionality, some functionality is not working, office function.
Search	48	31	Requires searching, search can be frustrating, hard to search for documentation, ease of search, keyword search features, search capabilities difficult, advanced searching engine, no cross-search area and search engine for a document.
Program	46	37	Different apps and programs, program can be unreliable, does not integrate with CAD programs, interfaces with existing construction and accounting programs, automated programs, programs go down and making the program better.
Organ	45	36	Organized, organization has registered expensive, documents from which organization to which organizations, file organize, upload and organize drawings and sheets were organized as they were meant to be.
Product	44	38	Working with Product, utilize a product, product review, productivity, workable product and other products cheaper,
Track	42	38	Document tracking lose track of things, project tracking, there is no backtracking through hundreds of emails, issue in tracking, difficult to track equipment use hours and no way of tracking sub-contractors.

5. DISCUSSION AND CONCLUSION

The overall sentiment analysis revealed that users incur both positive and negative experiences of collaboration tools. This is an intuitive finding, given the broad range of knowledge and experience within the target population frame. Although existing tools exist in large number, still users are face problems. Overall, the findings indicated that the document management features of tools are significant, and users are face issues regarding document findings, searches, and organization and file format aspects. For instance, “Document” word in Table 1 (Total occurrence 333) indicated that tools are judged by its overall document management aspect. However, in Table 2 the same word “Document” is associated with negative sentiment of tools indicating a variety of difficulties related to the document management features. Report features were also observed to be important to users. Issues and problems related to report features were identified and several users discussed the customization of report features. On the other hand, based on “project size” collaboration tools users experience, and tools adoption differs. Apart from these, customer service assistance of tools is an important criterion for users’ satisfaction. Moreover, user-friendliness of tools is also shown to be of significance.

The study investigated the users’ perception of collaboration technology and contributes to the wider body of knowledge in this area. By gaining a deeper and richer appreciation of both the negative and positive perceptions, industry practitioners are better able to implement strategies to maximize collaboration potential in their businesses. In turn, such knowledge could facilitate improvements in productivity performance on site and facilitate better business outcomes. The results present an insight on users’ perceptions regarding collaboration tools. The methodology adopted investigated big data and created a base for further analyzing the dataset. This methodology studied the open source domain data and thus analysis is reproducible. The study also identified the points against which collaboration tools proved satisfactory or unsatisfactory users. The study has limitations, in that it considered only the most frequent terms. Moreover, consideration of other groups of words and different tools may result in broader findings. Thus, wider sample may be considered in a future study to investigate users’ perception in greater detail.

REFERENCES:

Abanda, F. H.Vidalakis, C.H.Oti, A. and H.M.Tah, J. (2015), “A critical analysis of Building Information

- Modelling systems used in construction projects”. *Advances in Engineering Software*, Vol. 90. pp. 183-201. <http://dx.doi.org/10.1016/j.advengsoft.2015.08.009>
- Adriaanse, A.Voordijk, H. and Dewulf, G. (2010), “The use of interorganisational ICT in United States construction projects”. *Automation in Construction*, Vol. 19 No. 1. pp. 73-83. 10.1016/j.autcon.2009.09.004
- Arianto, R.Gaol, F. L.Abdurachman, E.Heryadi, Y.Warnars, H. L. H. S.Soewito, B. and Pérez-Sánchez, H. 2017. Quality measurement of android messaging application based on user experience in Microblog. *2017 International Conference on Applied Computer and Communication Technologies (ComCom)*. IEEE.
- Bi, J.-W.Liu, Y. and Fan, Z.-P. (2019), “Representing sentiment analysis results of online reviews using interval type-2 fuzzy numbers and its application to product ranking”. *Information Sciences*, Vol. 504. pp. 293-307. <https://doi.org/10.1016/j.ins.2019.07.025>
- Capterra. 2018. *Construction Management Software* [Online]. Available: <https://www.capterra.com/construction-management-software/> [Accessed November 11 2018].
- Capterra. 2020. *Construction Project Management Software* [Online]. Available: <https://www.capterra.com.au/directory/30057/construction-management/software> [Accessed April 29 2020].
- Charalambous, G.Demian, P.Yeomans, S. and Thorpe, T. 2017. Impact of collaboration tools and shaping the future of data exchange – A model for BIM communication waste. In: RINATH PERERA, E. A. (ed.) *Advances in Construction ICT and E-Business*.
- Comiskey, D.McKane, M.Jaffrey, A.Wilson, P. and Mordue, S. (2017), “An analysis of data sharing platforms in multidisciplinary education”. *Architectural Engineering and Design Management*, Vol. 13 No. 4. pp. 1-18. 10.1080/17452007.2017.1306483
- Costa, A. A. and Tavares, L. V. (2012), “Social e-business and the Satellite Network model: Innovative concepts to improve collaboration in construction”. *Automation in Construction*, Vol. 22. pp. 387-397. <https://doi.org/10.1016/j.autcon.2011.09.017>
- Crowd, G. 2018. *Best Construction Management Software* [Online]. Available: <https://www.g2crowd.com/categories/construction-management> [Accessed November 11 2018].
- East, E. W.Kirby, J. G. and Liu, L. Y. (2008), “Verification and validation of a project collaboration tool”. *Automation in Construction*, Vol. 17 No. 2. pp. 201-214. <https://doi.org/10.1016/j.autcon.2007.04.003>
- Ertek, G.Tapucu, D. and Arın, I. 2014. Text Mining with Rapidminer. In: HOFMANN, M. & KLINKENBERG, R. (eds.) *Rapid Miner Data Mining Use Cases and Business Analytics Applications*. Chapman and Hall/CRC, New York.
- FinancesOnline. 2018. *Scoring methodology* [Online]. Available: <https://financesonline.com/scoring-methodology/> [Accessed November 20 2018].
- Hosseini, M. R.Martek, I.Chileshe, N.Zavadskas, E. K. and Arashpour, M. (2018a), “Assessing the Influence of Virtuality on the Effectiveness of Engineering Project Networks: “Big Five Theory” Perspective”. *Journal of Construction Engineering and Management*. 10.1061/(ASCE)CO.1943-7862.0001494.
- Hosseini, M. R.Martek, I.Papadonikolaki, E. and Sheikhhoshkar, M. (2018b), “Viability of the BIM Manager Enduring as a Distinct Role: Association Rule Mining of Job Advertisements”. *Journal of Construction Engineering and Management*, Vol. 144 No. 9. 10.1061/(ASCE)CO.1943-7862.0001542
- Hosseini, M. R.Zavadskas, E. K.Xia, B. and Mills, A. (2017), “Communications in hybrid arrangements: Case of Australian construction project teams”. *Engineering Economics*, Vol. 28 No. 3. pp. 290-300. 10.5755/j01.ee.28.3.13791

- Kracunas, B. and Kracunas, B. 2016. *Technology tools to boost collaboration in construction industry* [Online]. Available: <https://rsmus.com/what-we-do/industries/real-estate/five-ways-to-invest-wisely-in-technology-for-construction.html> [Accessed April 29 2020].
- Ma, Z.Zhang, D. and Li, J. (2018), “A dedicated collaboration platform for Integrated Project Delivery”. *Automation in Construction*, Vol. 86. pp. 199-209. <https://doi.org/10.1016/j.autcon.2017.10.024>
- Mignone, G.M.Reza HosseiniChileshe, N. and Arashpour, M. (2016), “Enhancing collaboration in BIM-based construction networks through organisational discontinuity theory: a case study of the new Royal Adelaide Hospital”. *ARCHITECTURAL ENGINEERING AND DESIGN MANAGEMENT*, Vol. 12 No. 5. pp. 333-352. 10.1080/17452007.2016.1169987
- Oraee, M.Hosseini, M. R.EleniPapadonikolakiPalliyaguru, R. and Arashpour, M. (2017), “Collaboration in BIM-based construction networks: A bibliometric-qualitative literature review”. *International Journal of Project Management*, Vol. 35 No. 7. pp. 1288-1301. <https://doi.org/10.1016/j.ijproman.2017.07.001>
- Papadonikolaki, E.Oel, C. v. and Kagiogl, M. (2019), “Organising and Managing boundaries: A structural view of collaboration with Building Information Modelling (BIM)”. *International Journal of Project Management*, Vol. 37 No. 3. pp. 378-394. <https://doi.org/10.1016/j.ijproman.2019.01.010>
- Softwareadvice. 2018. *Web Based Construction Management Software* [Online]. Available: <https://www.softwareadvice.com/au/> [Accessed December 15 2018].
- Yu, A. T. W.Shen, Q.Kelly, J. and Hunter, K. (2006), “An Investigation of Critical Success Factors in Construction Project Briefing by Way of Content Analysis”. *Journal of Construction Engineering and Management* Vol. 132 No. 11. 10.1061/(ASCE)0733-9364(2006)132:11(1178)
- Zhang, J.Liu, Q.Hu, Z.Lin, J. and Yu, F. (2017), “A multi-server information-sharing environment for cross-party collaboration on a private cloud”. *Automation in Construction*, Vol. 81. pp. 180-195. <https://doi.org/10.1016/j.autcon.2017.06.021>

AN IMAGE FEATURE CLASSIFICATION SYSTEM FOR PIERS BASED ON SEMANTIC SEGMENTATION WITH DEEP LEARNING

Natthapol Saovana, Nobuyoshi Yabuki, and Tomohiro Fukuda
Osaka University, Japan

ABSTRACT: Image feature detection from digital images is one of the first steps in photogrammetric techniques that can be utilized to support the inspection and progress tracking on the construction site. However, processing these features solely can cause difficulties for feature matching, especially from the vegetation and rough terrain surrounding infrastructure projects, which usually consist of many outliers and unnecessary features. This study proposes the use of a deep convolutional neural network combining with Delaunay triangulation to automatically classify the features of interest. The experiment result showed that our system was able to perform well on the testing set of piers of bridges, viaducts, etc. The features inside the image of piers were rapidly and automatically classified within twelve microseconds per image. Using this proposed system can support the further steps of photogrammetric techniques to be able to focus more on the object of interests hence improve the quality of the output. For the future plan, we would like to expand the capability of our system to be able to handle the three-dimensional environment such as classifying point clouds from Structure from Motion.

KEYWORDS: Feature classification, Deep learning, Delaunay triangulation

1. INTRODUCTION

Site inspection and construction progress tracking currently rely on manual processes (Braun et al., 2018). Nevertheless, in the gigantic construction site such as infrastructure projects, it is very challenging to keep track of changes manually, raising the demand for automated techniques to support these work procedures (Jog et al., 2011). Vision-based methods are proved to be able to provide a satisfactory result with affordable prices (Yuan et al., 2017). Therefore, the utilization of images with computer vision has been considered to be critical assistance for civil engineering inspection and tracking (Spencer et al., 2019).

Image feature detection from digital images is a fundamental method in the computer vision domain (Apollonio et al., 2014; Li et al., 2015). By classifying these features enables the opportunity to better manage the further work processes such as feature matching, image registration, and point cloud generation from photogrammetric techniques. However, although image feature extraction by utilizing feature detection algorithms can rapidly discover the meaningful pixels, the image matching from these features is prone to error from outliers that can decrease the matching accuracy (Ali and Whitehead, 2014) and reduce the overall quality, especially when it has to deal with challenging scenes such as a rough terrain of infrastructure scenes with numerous unnecessary features of the vegetation and boulders (Saovana et al., 2019b).

Thus, there is a need for a novel system to assist the image feature classification to better specify the features of interest from the infrastructure sites. One of the promising techniques that may be able to support this work process is the semantic image segmentation from deep learning algorithms, which can give the boundary of the object of interest inside each image based on the pre-trained knowledge. Nevertheless, to the best of our knowledge, there are no studies that focus on these aspects. Therefore, to fill this research gap, this study proposes the development of a new system to automatically classify the features of interest inside infrastructure images based on pre-trained deep learning. The result of this study is then evaluated with the manual process to verify its usability with a real-world case.

2. LITERATURE REVIEW

This chapter is separated into three parts. The first topic covers the explanation of image features in the context of this study. The second topic is about semantic image segmentation and previous works on this scope. The last topic in this chapter discusses Delaunay triangulation and its usage.

2.1 Image features

Image features, in this aspect, are the important areas or pixels in an image that are selected by the feature detector algorithm based on the difference of intensity with their adjacent area (Li et al., 2015). These features can be

detected as edges, corners, and blobs inside an image. Edges are lines constructed from the disjunction of pixel intensity. An example algorithm is the Canny edge detector (Canny, 1986), which utilizes an adaptive thresholding detector with hysteresis to eliminate the weaker edges than the lowest threshold. The result of the Canny edge detector is the contours constructed from the detected edges (Bradski and Kaehler, 2008).

Corners are formed by the points of intersection between two or more edges. Harris corner detector (Harris and Stephens, 1988) is one of the famous algorithms in this category. It also utilizes hysteresis procedures like a Canny edge detector. The output of this algorithm is five classes, namely the background, two classes of corners, and two classes of edges. The algorithm deletes the exceeded and isolated edges and then, joins short and discontinuous edges together. The ends of these edges that form corners are shown as the result of the detection.

Finally, blobs or areas of interest in an image are the locations that contain many similar points. The algorithms that work on blob detection operate for both point and area detections. However, point detection relies on corner detection but finding the area of interest is instead a kind of image segmentation (Li et al., 2015). The representative point of each blob is chosen from the difference of intensity between samples inside that blobs. Examples of blob detection are Scale Invariant Feature Transform (SIFT) (Lowe, 2004) and Speeded Up Robust Features (SURF) (Bay et al., 2008). SIFT utilizes the Difference of Gaussians (DoG), which roughly gained from the approximation of Laplacian of Gaussian (LoG), to find a promising area that may contain points of interest. A DoG is the difference of Gaussian blurring of the same image but dissimilar sigma value finding the extreme point inside a set of neighbors over the image, both in the same scale and space (Bradski and Kaehler, 2008). This procedure is continuously processed in every octave of the Gaussian pyramid setting of the algorithm. When the rough areas are specified, they are then precisely sought through to find the feature inside. The extreme points inside each area that do not surpass the predefined edge and contrast thresholds will be removed. On the other hand, SURF implements Box Filter with LoG that can process rapidly and collaterally in many parts of an image. SURF also utilizes the determinant of the Hessian matrix for the location and scale of the detection, which is different from the sigma and thresholds of SIFT.

As mentioned before, feature detection from digital images is a fundamental method in the computer vision domain (Apollonio et al., 2014). They can be used to track equipment and staff on site (Brilakis et al., 2011), template matching (Oron et al., 2018), and image stitching (Qu et al., 2015). They can then be further processed through numerous photogrammetric techniques, for example, Structure from Motion (Westoby et al., 2012) and Multi-View Stereo (Furukawa and Ponce, 2010), to construct a point cloud or model based on the matchings of these features solving for the intrinsic information of the camera.

2.2 Semantic Image Segmentation

Semantic image segmentation is one of the major scopes in computer vision. The procedures of semantic segmentation are processing the input image into the system and letting the system color which pixels inside the image belong to which classes. Currently, deep convolutional neural networks (DCNNs) such as U-Net (Ronneberger et al., 2015) have been focused in many academic studies (Zhao et al., 2018), which when utilized for image segmentation, they can understand the scene inside the image well and satisfactory results can be achieved (Garcia-Garcia et al., 2018).

DCNNs contain many layers that act as human neurons to understand the input knowledge such as images and speeches and try to solve the problem in the same scope of the knowledge. The design of the DCNN is usually separated into encoder and decoder parts (Badrinarayanan et al., 2017). The encoder decreases the size of the input image to discover the features in the input image. Conversely, the decoder increases the size of feature maps to understand the location of each object class. These parts usually work separately but utilizing a copy-and-paste method that copies some parts of the feature map from the encoder and pastes into the feature map of the decoder part can raise the performance of the DCNN (Amirkolaee and Arefi, 2019; Ronneberger et al., 2015).

Semantic segmentation was implemented with numerous scopes of studies inside the civil engineering aspect. Macher et al. (2017) proposed the use of a deep learning algorithm to segment the point cloud and semi-automatically convert the point cloud into three-dimensional Building Information Models of grounds, ceilings, and walls. Khoshboresh Masouleh and Shah-Hosseini (2019) utilizes a deep learning model to segment vehicles and equipment in real-time from the image of a drone. Yan et al. (2019) introduced the usage of semantic segmentation to extract the pattern features of buildings from a topological map. Therefore, semantic segmentation from a DCNN is very promising to be able to assist the feature classification of infrastructure piers but the studies in this scope have not yet to be seen.

2.3 Delaunay Triangulation

Delaunay triangulation was first introduced by Delaunay (1934). Its concept was in a set of discrete points (P) in a plane, there are no points in P that are inside the circumcircles of any triangles formed by points in P (Guibas and Stolfi, 1985). Delaunay triangulation was utilized in numerous scopes of works such as surface reconstruction (Mineo et al., 2019), boundary point extraction (Brie et al., 2016), and feature match verification (Jiang and Jiang, 2019).

By implementing Delaunay triangulation with surface reconstruction, it can generate the boundary of the surface that the vertices inside the surface can be determined by other algorithms such as Poisson’s equation (Kazhdan et al., 2006). Due to its easy-utilization and high efficiency, Delaunay triangulation is the most famous algorithm for problems related to the triangulation of point clouds (Mineo et al., 2019). It can handle both two-dimensional and three-dimensional problems. Moreover, Guibas and Stolfi (1985) introduced the InCircle algorithm that utilized the determinant of at least three vertices that formed a Delaunay triangle and another point requiring the checking if it is inside the circle that had these three points on its line, which was called the circumcircle. If the determinant between these points is a positive value, then it means that the checking point is inside that circumcircle.

3. EXPERIMENTATION

The experimentation of this study is shown in Fig. 1. First, the features inside test images were specified by a feature detector algorithm. Then, the test images are utilized as inputs for the pre-trained DCNN to segment the object of interest inside each image. Next, the contour of the segmented image outputs from the previous step is extracted and used as the boundary of the object of interest. Finally, the boundary is processed into Delaunay triangulation to find the features inside the object of interest. The output of the system is further compared to the manual image editing to validate the performance of the system.

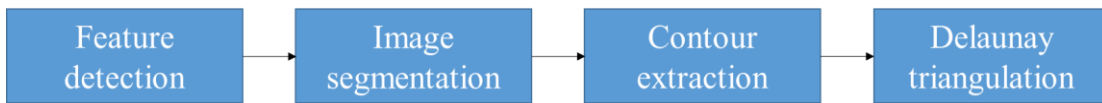


Fig. 1: Experimental procedure of this study

The testing image set was captured from an infrastructure site in Nakhon Ratchasima, Thailand. The image capturing equipment was a DJI Phantom 4 drone. The resolution of the image was $1,920 \times 1,080$ pixels in PNG format. The object of interest in this dataset is the piers inside the images. The feature detector algorithm in this study was the SURF detector (Bay et al., 2008), which had a satisfactory result with infrastructure images (Saovana et al., 2019a, 2019b). The setting of the algorithm is the default value from OpenCV 3.4.2 (Bradski and Kaehler, 2008), which is an open-source library for image management. The specification of the testing computer is Intel® Core™ i5-8400 CPU @ 2.80GHz and 8.00 GB RAM. Fig. 2 shows the detected features from the SURF algorithm.

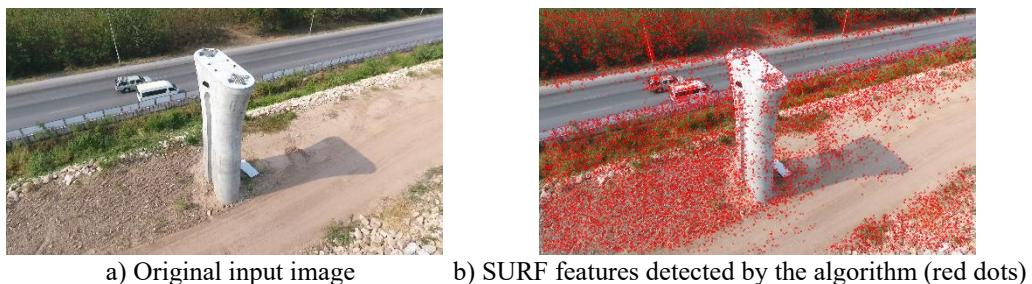


Fig. 2: Sample of detected features from the SURF algorithm

The DCNN in our experiment utilized the architecture inspired by U-Net (Ronneberger et al., 2015). It contains encoder and decoder parts, which also connected with the copy-and-paste process that can raise the quality of the segmentation result. U-Net has been recognized by its high accuracy in many scopes of works (Abrams et al., 2019; Garcia-Garcia et al., 2018; Izutsu et al., 2019). Our DCNN was trained on one thousand images and tested on one hundred twenty-five images. It should be noted that our system had never seen the test data in order to also proof the generalization of the system. The detailed information on train and test sets are shown in Table 1. Data

augmentation was implemented to raise the number of images in the train set by up to 10° angle rotation, horizontal flipping, and brightness adjusting.

Table 1: The detailed information on train and test sets

Parameter	Train set			Test set
	Original images	Augmented images	Total images	
Number of images	125	875	1,000	125

Training was conducted on a computer that has specifications as follows: Intel® Core™ i7-8086K CPU @ 4.00GHz with 32.0 GB of RAM and an NVIDIA GeForce RTX 2080 Ti graphics card. The DCNN was performed on Tensorflow, which is an open-source platform for deep learning. Three hundred epochs were set as the number of training with the batch size of one, the learning rate of 0.00001, and decay rate of 0.995. These hyperparameters were set so the system can slowly reach the most optimal answer without overfitting. The optimization strategy for learning is to minimize the loss in each epoch of training. There are two classes in the training, which were piers and background. The validation of the network was based on four aspects, namely precision, recall, F1 score, and intersection over union (IoU). The formulas utilized to calculate for these values are shown as formula (1) to (4):

$$\text{Precision} = \frac{SP_C}{SP_T} , \quad (1)$$

$$\text{Recall} = \frac{SP_C}{SP_{GT}} , \quad (2)$$

$$\text{F1} = \frac{2 \times \text{Precision} \times \text{Recall}}{\text{Precision} + \text{Recall}} , \quad (3)$$

$$\text{IoU} = \frac{SP_C \cap SP_{GT}}{SP_T \cup SP_{GT}} , \quad (4)$$

where SP_C is the number of true positive segmented pixels, SP_T is the total number of pixels that DCNN decided to segment, and SP_{GT} is the total number of ground truth pixels. In the case of IoU, $SP_C \cap SP_{GT}$ is the number of true positive pixels from the segmented image that intersect with the ground truth pixels, and $SP_T \cup SP_{GT}$ is the number of pixels that formed from the union of segmented pixels from the DCNN and the ground truth.

Moreover, we also utilized 5-fold cross-validation (5-fold CV) to quantify the performance of our DCNN on the train set. k -fold cross-validation is a method to evaluate the generalization of the network over the training images (German et al., 2012). The cross-validation was conducted by separating the images inside the train set into five groups. Then, each group was implemented as the validation set in each network training. After five times of training, all of the validated performance were averaged to find the values represented the performance of the network over the train set. Table 2 shows the final performance of the DCNN in this study and Fig. 3 shows the training performance of the DCNN proposed in this study.

Table 2: Final performance parameters of the DCNN in the proposed system over the train and test sets

Parameters	Train set	Test set
	(5-fold CV)	
Precision	97.78%	97.52%
Recall	97.62%	97.43%
F1 score	97.70%	97.48%
IoU	82.60%	83.45%

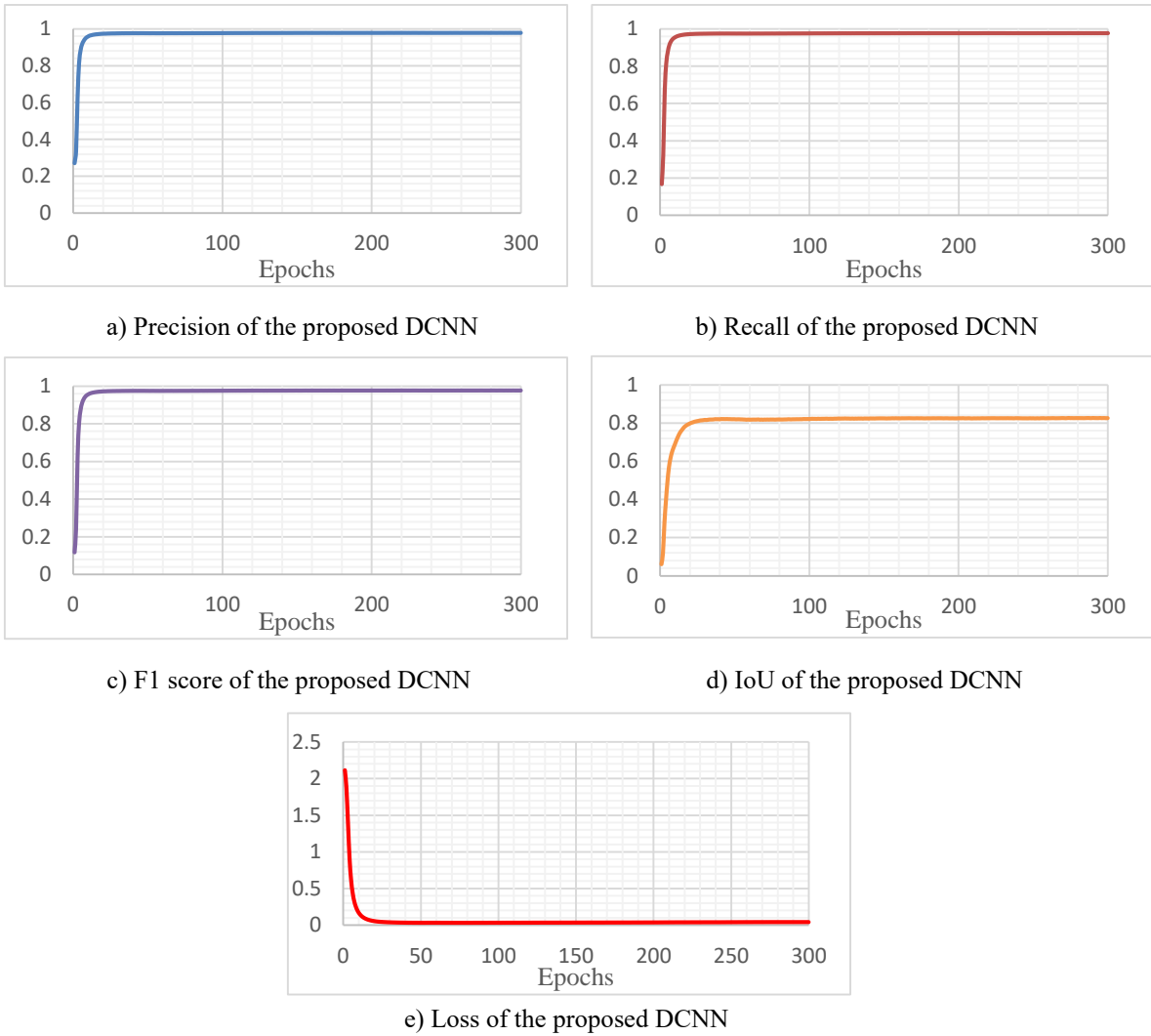


Fig. 3: Performance of the DCNN when training with 5-fold cross-validation in this study

The performance of our network over train and test sets was satisfactory with the result over 97% in precision, recall, and F1 score, in which the values over the test set are slightly lower than the ones from the test set, showing the good generalization between train and test sets. However, although the performance of the DCNN over a test set should normally be lower than the one from a train set, our network can perform on the test set better than the train set in the aspect of IoU. This situation can be inferred as the data augmentation such as rotating and brightness adjusting complicated the training of the network and decreased the performance of the training set. On the other hand, all of the images in the test set were general and easy to understand. Fig. 4 shows an example of a segmented image.

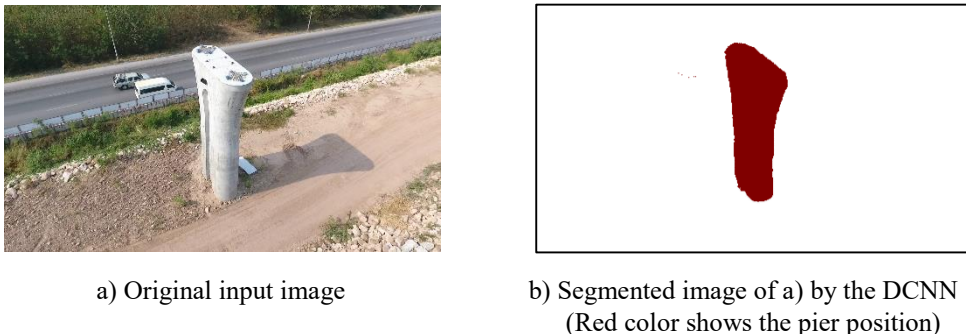


Fig. 4: Example of a segmented image

Next, the segmented images of each test image were processed to extract the boundary of the piers inside each image. Canny edge detector (Canny, 1986) was implemented to extract the boundary of the segmented images. Canny edge detector utilizes thresholding with hysteresis, therefore the maximum and minimum thresholds must be set. There was a recommendation to set the maximum threshold equals two times the minimum threshold (Canny, 1986). However, the minimum threshold varies by cases and needs to be examined in order to get the optimal value. Thus, the optimal thresh for extracting the boundary was also investigated. Fig. 5 shows an example of boundary extraction.

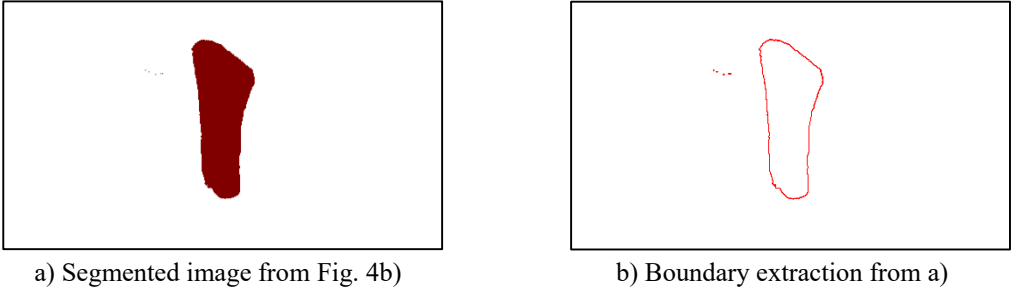


Fig. 5: Example of an extracted boundary image

This boundary was further processed for Delaunay triangulation (Delaunay, 1934) by extracting the vertices on the boundary and utilizing these points to form the triangulation. Fig. 6 shows the result after applying Delaunay triangulation. The blue color was the triangles that were formed based on these vertices. These triangles were implemented with the InCircle test proposed by Guibas and Stolfi (1985) to check which features from the feature detection step are in the boundary of the piers. In order to reduce the complexity from noises in the segmentation stage, the boundaries smaller than twenty square pixels were not processed in this step.

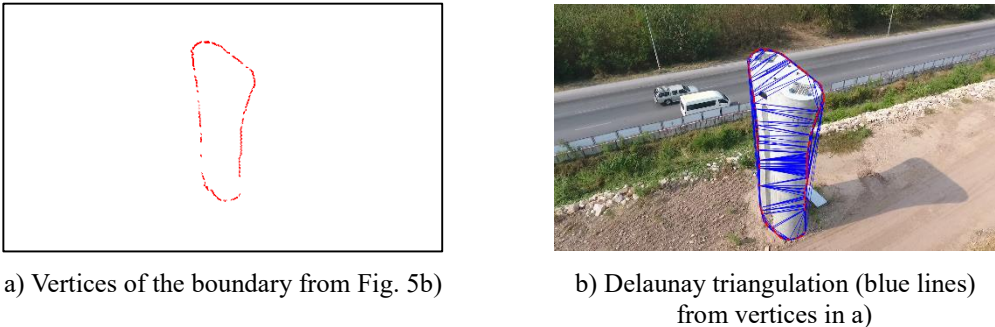


Fig. 6: Example of Delaunay triangulation from vertices on the boundary of the object of interest

The concept of the InCircle test is for a set of points $P = \{P_1, P_2, P_3\}$ as shown in Fig. 7, if point Q is inside the circumcircle of P_1 to P_3 , the determinant of these points will be a positive value. The formula for the determinant checking is shown in formula (5).

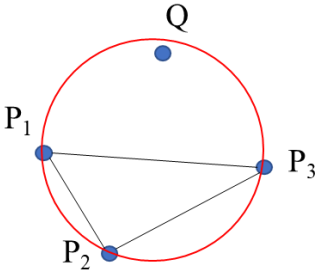


Fig. 7: Point Q and a circumcircle made from Delaunay triangulation of P_1 to P_3

$$\begin{vmatrix} P_{1x} & P_{1y} & P_{1x}^2 + P_{1y}^2 & 1 \\ P_{2x} & P_{2y} & P_{2x}^2 + P_{2y}^2 & 1 \\ P_{3x} & P_{3y} & P_{3x}^2 + P_{3y}^2 & 1 \\ Q_x & Q_y & Q_x^2 + Q_y^2 & 1 \end{vmatrix} = \begin{vmatrix} P_{1x} - Q_x & P_{1y} - Q_y & (P_{1x}^2 - Q_x^2) + (P_{1y}^2 - Q_y^2) \\ P_{2x} - Q_x & P_{2y} - Q_y & (P_{2x}^2 - Q_x^2) + (P_{2y}^2 - Q_y^2) \\ P_{3x} - Q_x & P_{3y} - Q_y & (P_{3x}^2 - Q_x^2) + (P_{3y}^2 - Q_y^2) \end{vmatrix} \\
= \begin{vmatrix} P_{1x} - Q_x & P_{1y} - Q_y & (P_{1x} - Q_x)^2 + (P_{1y} - Q_y)^2 \\ P_{2x} - Q_x & P_{2y} - Q_y & (P_{2x} - Q_x)^2 + (P_{2y} - Q_y)^2 \\ P_{3x} - Q_x & P_{3y} - Q_y & (P_{3x} - Q_x)^2 + (P_{3y} - Q_y)^2 \end{vmatrix} \quad (5)$$

The features that were able to be substituted into formula (5) and make the determinant to be a positive value were added into a set of features that were inside the pier. Fig. 8 shows the comparison between all features detected by the SURF detector and the features inside the pier classified by the proposed system. The output of the system was validated with the manual editing process and the quantitative performance was also presented in the next chapter.



a) All features inside the original image b) Features inside the pier from the proposed system

Fig. 8: Comparison between images of all SURF features and SURF features inside the pier (red dots)

4. RESULTS

The results from processing one hundred twenty-five images of the test image set into the proposed system with different thresholds of Canny edge detector are shown in Table 3 compared with manual background removal. Please be noted that these values were gained from the average of one hundred processing times of each image inside the testing set in order to decrease the effect of computational errors during the testing.

Table 3: Results from the proposed system processed at different thresholds

Parameters	Detected contour (Contour)	Pier features (Point)	Boundary point extraction (Microsecond)	Feature classification using Delaunay triangulation (Microsecond)	Total computational time (Microsecond)
Manual background removal		1,863			
Threshold = 1	1,427	1,855	10.588	1.832	12.420
Threshold = 50	1,427	1,855	10.790	1.867	12.657
Threshold = 100	1,427	1,855	10.808	1.872	12.680
Threshold = 150	1,427	1,855	10.828	1.874	12.702
Threshold = 200	1,427	1,855	11.015	1.898	12.913
Threshold = 250	1,427	1,855	11.026	1.901	12.927

From Table 3, there are no differences for numbers of detected contours by the Canny edge detector although the thresholds were set differently. The numbers of pier features are also the same in each threshold. The amount of the pier features processed by the proposed system is not much dissimilar (-0.43%) to the baseline of manual background removal to find the number of features inside the pier.

To further illustrate the trend of the computational times between different thresholds, Fig. 9 shows the comparison between these values. The computational time for feature classification using Delaunay triangulation has nearly no differences between the values of threshold. However, the required time for boundary point extraction is different based on the number of the threshold. The bigger amounts of thresholds slow down the process, in which when combining the total computational time, the setting with higher numbers of threshold delays the finishing time of the proposed system as well.

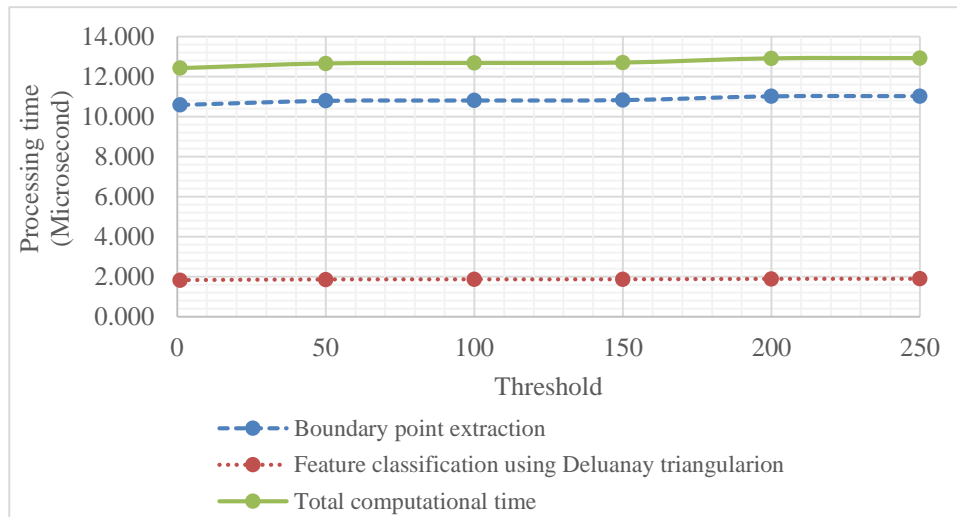


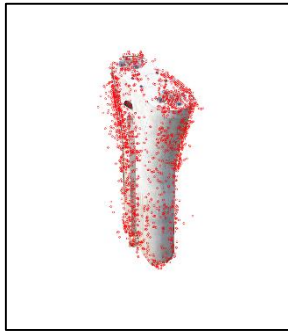
Fig. 9: Comparison between processing time in each step at different thresholds

5. DISCUSSION

The proposed system that the minimum threshold of the Canny edge detector was set at various values was evaluated with the manual background removal about the number of detected pier features. Furthermore, the computational times of each threshold were also collected and compared to validate the effect of thresholding with the processing of the proposed system.

According to the number of detected features, utilizing the proposed system did not complicate the feature detection of the original images. There is only 0.43% difference between the detected features by the proposed system compared to the manual background removal of the original image. Moreover, removing the background to find the features inside the pier also has some disadvantages with the SURF detector as can be seen in Fig. 10. Although the background of Fig. 10a) was removed completely, SURF detector still detected some features outside the pier due to its detection procedure that separates images into various small batches through the entire image. Therefore, some features in the clean background can still be a candidate of the detection inside some image batches that have both pier pixels and background pixels, in which this situation might be able to complicate the feature matching when processed into further steps of photogrammetric techniques and reduce the quality of the output.

For the computational time, setting a higher threshold resulted in taking more time to finish the entire process of feature classification. The reason is because of the process that the Canny algorithm used to detect edges inside an image. The detector applies the maximum threshold, which is two times higher than the minimum one, to find the edges that have the intensity lower than the maximum threshold. Next, the Canny algorithm tracks the detected edges along their lines until these edges have lower intensity than the minimum threshold. By applying high minimum threshold values means that the algorithm has to track the intensity in a wider range and requiring more time to finish the computation. However, a segmented image from the DCNN does not have much difference in intensity, in which the setting of a higher threshold is unnecessary and resource-consuming as shown in Table 3 that there is no difference in the number of detected contours although the thresholds were different. Thus, applying a low threshold is encouraged when utilizing a Canny edge detector with a segmented image.



a) Detected features from manual removal



b) Detected features from the proposed system

Fig. 10: Comparison of detected pier features (red dots) from the manual process and our proposed system

6. CONCLUSION

Feature detection is a fundamental work procedure in order to implement vision-based techniques based on digital images to support the inspection and progress tracking on construction sites, especially with the gigantic-size infrastructure projects that manual tasks are not proved to be effective. However, the outliers and excessive features from surrounding such as the vegetation and boulders can complicate the matching of features of interest and decrease the quality of the output from photogrammetric techniques.

In this study, we proposed the use of a DCNN combining with Delaunay triangulation to automatically classify the features of interest in digital images. Our developed system utilized a DCNN to verify the objects of interest, which in this case was the piers of an infrastructure site, by letting the DCNN segment the pixels that belong to the pier class. Our DCNN was able to achieve over 97% in precision, accuracy, and F1 score, both in train and test sets. The IoU of the network for the test set was also considerably high at 83%. Then, the boundaries of the piers from segmented images were extracted by the Canny edge detector with different threshold settings. The vertices on these boundaries were further utilized with Delaunay triangulation. Finally, the detected features from the SURF detector of the original image were processed with the triangles formed by Delaunay triangulation to find the features that were inside the piers by using the InCircle test (Guibas and Stolfi, 1985).

The results showed that our proposed system was able to rapidly and automatically classified the features of interest based on the segmented images. The entire process for an image with a resolution of $1,920 \times 1,080$ pixels was finished in approximately twelve microseconds, in which it is promising to be operated on a real-time basis. The number of classified features was also nearly equal to the manual background removal process. Moreover, we found that setting the threshold of the Canny edge detector lower when processed with the segmented images from a DCNN was able to decrease the computational time without reducing the number of detected contours.

Nevertheless, there are some limitations of this study to be noted. First, the total computational time in this study did not include the required time for the DCNN to finish the segmentation process. Second, due to the constrain of a convex hull from OpenCV (Bradski and Kaehler, 2008), when implemented with a concave boundary, it may construct a hull bigger than the actual boundary. Thus, the triangles from Delaunay triangulation might be formed outside the boundary as shown in Fig. 6b) that there are some blue lines outside of the red boundary line. This situation can result in some excess features classified as features of interest. For the future work, we plan to further upgrade our proposed system to be able to tackle with the three-dimensional environment such as point clouds from Structure from Motion.

7. REFERENCES

- Abrams, J. F., Vashishtha, A., Seth, T. W., Nguyen, A., Mohamed, A., Wieser, S., Kuijper, A., Wilting, A., and Mukhopadhyay, A. (2019). Habitat-Net: Segmentation of habitat images using deep learning. *Ecological Informatics*, 51(May), 121–128. <https://doi.org/10.1101/483222>
- Ali, H., and Whitehead, A. (2014). Modern to Historic Image Matching: ORB / SURF an Effective Matching Technique. *International Conference on Computers and Their Applications*, 321–326.

- Amirkolae, H. A., and Arefi, H. (2019). Height estimation from single aerial images using a deep convolutional encoder-decoder network. *ISPRS Journal of Photogrammetry and Remote Sensing*, 149(July 2018), 50–66. <https://doi.org/10.1016/j.isprsjprs.2019.01.013>
- Apollonio, F. I., Ballabeni, A., Gaiani, M., and Remondino, F. (2014). Evaluation of feature-based methods for automated network orientation. *International Archives of the Photogrammetry, Remote Sensing and Spatial Information Sciences - ISPRS Archives*, 40(5), 47–54. <https://doi.org/10.5194/isprsarchives-XL-5-47-2014>
- Badrinarayanan, V., Kendall, A., and Cipolla, R. (2017). SegNet: A Deep Convolutional Encoder-Decoder Architecture for Image Segmentation. *IEEE Transactions on Pattern Analysis and Machine Intelligence*, 39(12), 2481–2495.
- Bay, H., Ess, A., Tuytelaars, T., and Van Gool, L. (2008). Speeded-Up Robust Features (SURF). *Computer Vision and Image Understanding*, 110(3), 346–359. <https://doi.org/10.1016/j.cviu.2007.09.014>
- Bradski, G., and Kaehler, A. (2008). *Learning OpenCV* (M. Loukides (ed.); First Edit). O'REILLY. <https://doi.org/10.1109/MRA.2009.933612>
- Braun, A., Tuttas, S., Stilla, U., and Borrmann, A. (2018). Process- and computer vision-based detection of as-built components on construction sites. *Proceedings of the 35th International Symposium on Automation and Robotics in Construction and Mining*, 7. https://publications.cms.bgu.tum.de/2018_braun_isarc.pdf
- Brie, D., Bombardier, V., Baeteman, G., and Bennis, A. (2016). Local surface sampling step estimation for extracting boundaries of planar point clouds. *ISPRS Journal of Photogrammetry and Remote Sensing*, 119, 309–319. <https://doi.org/10.1016/j.isprsjprs.2016.06.006>
- Brilakis, I., Park, M. W., and Jog, G. (2011). Automated vision tracking of project related entities. *Advanced Engineering Informatics*, 25(4), 713–724. <https://doi.org/10.1016/j.aei.2011.01.003>
- Canny, J. (1986). A Computational Approach to Edge Detection. *IEEE Transactions on Pattern Analysis and Machine Intelligence*, PAMI-8, No.6, 679–698. <https://doi.org/10.1109/ASICON.2011.6157287>
- Delaunay, B. (1934). Sur la sphère vide. *Bulletin de l'Académie Des Sciences de l'URSS, Classe Des Sciences Mathématiques et Naturelles*, 6, 793–800.
- Furukawa, Y., and Ponce, J. (2010). Accurate, dense, and robust multiview stereopsis. *IEEE Transactions on Pattern Analysis and Machine Intelligence*, 32(8), 1362–1376. <https://doi.org/10.1109/TPAMI.2009.161>
- Garcia-Garcia, A., Orts-Escolano, S., Oprea, S., Villena-Martinez, V., Martinez-Gonzalez, P., and Garcia-Rodriguez, J. (2018). A survey on deep learning techniques for image and video semantic segmentation. *Applied Soft Computing Journal*, 70, 41–65. <https://doi.org/10.1016/j.asoc.2018.05.018>
- German, S., Brilakis, I., and Desroches, R. (2012). Rapid entropy-based detection and properties measurement of concrete spalling with machine vision for post-earthquake safety assessments. *Advanced Engineering Informatics*, 26(4), 846–858. <https://doi.org/10.1016/j.aei.2012.06.005>
- Guibas, L., and Stolfi, J. (1985). Primitives for the Manipulation of General Subdivisions and the Computation of Voronoi. *ACM Transactions on Graphics (TOG)*, 4(2), 74–123. <https://doi.org/10.1145/282918.282923>
- Harris, C., and Stephens, M. (1988). A Combined Corner and Edge Detector. *Alvey Vision Conference*, 50. <https://doi.org/10.5244/c.2.23>
- Izutsu, R., Yabuki, N., and Fukuda, T. (2019). As-built detection of steel frame structure using deep learning. *The 4th International Conference on Civil and Building Engineering Informatics (ICCBIEI)*, 25–32.
- Jiang, S., and Jiang, W. (2019). Reliable image matching via photometric and geometric constraints structured by Delaunay triangulation. *ISPRS Journal of Photogrammetry and Remote Sensing*, 153(April), 1–20. <https://doi.org/10.1016/j.isprsjprs.2019.04.006>
- Jog, G. M., Fathi, H., and Brilakis, I. (2011). Automated computation of the fundamental matrix for vision based construction site applications. *Advanced Engineering Informatics*, 25(4), 725–735. <https://doi.org/10.1016/j.aei.2011.03.005>

- Kazhdan, M., Bolitho, M., and Hoppe, H. (2006). Poisson Surface Reconstruction. *Eurographics Symposium on Geometry Processing*. <http://www.cs.jhu.edu/~misha/MyPapers/SGP06.pdf>
- Khoshboresh Masouleh, M., and Shah-Hosseini, R. (2019). Development and evaluation of a deep learning model for real-time ground vehicle semantic segmentation from UAV-based thermal infrared imagery. *ISPRS Journal of Photogrammetry and Remote Sensing*, 155(January), 172–186. <https://doi.org/10.1016/j.isprsjprs.2019.07.009>
- Li, Y., Wang, S., Tian, Q., and Ding, X. (2015). A survey of recent advances in visual feature detection. *Neurocomputing*, 149(PB), 736–751. <https://doi.org/10.1016/j.neucom.2014.08.003>
- Lowe, D. G. (2004). Distinctive Image Features from Scale-Invariant Keypoints. *International Journal of Computer Vision*, 60(2), 91–110. <https://doi.org/10.1023/B:VISI.0000029664.99615.94>
- Macher, H., Landes, T., and Grussenmeyer, P. (2017). From Point Clouds to Building Information Models: 3D Semi-Automatic Reconstruction of Indoors of Existing Buildings. *Applied Sciences*, 7(10), 1030. <https://doi.org/10.3390/app7101030>
- Mineo, C., Pierce, S. G., and Summan, R. (2019). Novel algorithms for 3D surface point cloud boundary detection and edge reconstruction. *Journal of Computational Design and Engineering*, 6(1), 81–91. <https://doi.org/10.1016/j.jcde.2018.02.001>
- Oron, S., Dekel, T., Xue, T., Freeman, W. T., and Avidan, S. (2018). Best-Buddies Similarity - Robust Template Matching Using Mutual Nearest Neighbors. *IEEE Transactions on Pattern Analysis and Machine Intelligence*, 40(8), 1799–1813. <https://doi.org/10.1109/TPAMI.2017.2737424>
- Qu, Z., Lin, S. P., Ju, F. R., and Liu, L. (2015). The Improved Algorithm of Fast Panorama Stitching for Image Sequence and Reducing the Distortion Errors. *Mathematical Problems in Engineering*, 2015. <https://doi.org/10.1155/2015/428076>
- Ronneberger, O., Fischer, P., and Brox, T. (2015). U-net: Convolutional networks for biomedical image segmentation. In N. Navab, J. Hornegger, W. Wells, and A. Frangi (Eds.), *Medical Image Computing and Computer-Assisted Intervention – MICCAI 2015*. *MICCAI 2015. Lecture Notes in Computer Science* (Vol. 9351). Springer, Cham. https://doi.org/10.1007/978-3-319-24574-4_28
- Saovana, N., Yabuki, N., and Fukuda, T. (2019a). A Performance Evaluation of Feature Detectors and Descriptors for Unmodified Infrastructure Site Digital Images. *4th International Conference on Civil and Building Engineering Informatics (ICCBEI2019)*, 113–120.
- Saovana, N., Yabuki, N., and Fukuda, T. (2019b). A Quantitative Effect Evaluation of the Unwanted Features Removal of Infrastructure Digital Images. *19th International Conference on Construction Applications of Virtual Reality (CONVR2019)*, 62–71.
- Spencer, B. F., Hoskere, V., and Narazaki, Y. (2019). Advances in Computer Vision-Based Civil Infrastructure Inspection and Monitoring. *Engineering*, 5(2), 199–222. <https://doi.org/10.1016/j.eng.2018.11.030>
- Westoby, M. J., Brasington, J., Glasser, N. F., Hambrey, M. J., and Reynolds, J. M. (2012). “Structure-from-Motion” photogrammetry: A low-cost, effective tool for geoscience applications. *Geomorphology*, 179(June 2018), 300–314. <https://doi.org/10.1016/j.geomorph.2012.08.021>
- Yan, X., Ai, T., Yang, M., and Yin, H. (2019). A graph convolutional neural network for classification of building patterns using spatial vector data. *ISPRS Journal of Photogrammetry and Remote Sensing*, 150(September 2018), 259–273. <https://doi.org/10.1016/j.isprsjprs.2019.02.010>
- Yuan, C., Li, S., and Cai, H. (2017). Vision-Based Excavator Detection and Tracking Using Hybrid Kinematic Shapes and Key Nodes. *Journal of Computing in Civil Engineering*, 31(1), 04016038. [https://doi.org/10.1061/\(ASCE\)CP.1943-5487.0000602](https://doi.org/10.1061/(ASCE)CP.1943-5487.0000602)
- Zhao, H., Qi, X., Shen, X., Shi, J., and Jia, J. (2018). ICNet for Real-Time Semantic Segmentation on High-Resolution Images. *ECCV*. https://doi.org/10.1007/978-3-030-01219-9_25

AWARENESS OF BIG DATA CONCEPT IN THE DOMINICAN REPUBLIC CONSTRUCTION INDUSTRY: AN EMPIRICAL STUDY

Paola F. Reyes-Veras, Suresh Renukappa and Subashini Suresh

Faculty of Science and Engineering, University of Wolverhampton, U.K.

ABSTRACT: *The construction industry, being one of the main characters in the ever-demanding need for technology developments, sometimes falls short of other industries in terms of implementation. The adoption of Big Data (BD) in industries like health and retail has had positive impacts in aspects such as decision-making processes and forecasting trends that allow planning some future business movements in advance. Hence, the question of whether these results can be recreated in construction industry. Therefore, this paper addresses the level of awareness identified as the first step towards implementation of the BD Concept within the construction industry of Dominican Republic (DR). Since little to no information exist on the subject the selected approach to perform this research was qualitative, twenty-one semi-structured interviews were studied using content analysis. Four levels of awareness is developed based on the Endsley situation awareness model. The results showed that nearly ninety-five percent of the interviewees had either no knowledge or a very basic awareness of the BD requirements or intermediate awareness but only five percent had actually applied BD in the construction industry. This paper provides the level of awareness of BD in the DR construction industry and provides evidence for the need to provide continuous professional development programmes for construction professionals and a need for an update of curriculum in construction-related education.*

KEYWORDS: *Awareness, Big Data, Construction, Dominican Republic, Technology, volume, and velocity.*

1. INTRODUCTION

Big Data is one of the emerging terms with more presence in today's technological society, several authors such as (Rabhi, Falih, Afraites, & Bouikhalene, 2019), (Wang, Wang, Yang, Zhu, & Liu, 2020), and (Tamimnia et al., 2020), have reported applications in various areas of science and engineering. The adoption of Big Data (BD) analysis in business and human resources management has had positive impacts in terms of improvement of the decision-making processes (Rabhi et al., 2019). Big Data works as a solution for the "what to do" with the ever-growing volume of information that is produced every second, and it has applications across business sectors.

After financial services, the construction industry generates the largest amount of data of any sector. A key challenge for the profession is how we use this data to improve what we deliver. Despite the promise of artificial intelligence (AI) and the Internet of Things industry, estimates suggest that up to 95% of construction industry data is not used but wasted (RICS, 2020). (Khan, 2008; RICS, 2020; Sitsabo Dlamini, 2012) noted that the construction industry plays an important part in the economic growth of the countries. It is indeed one of the main characters in resources consumption and thus the ever-demanding need for technology developments. Being that the case, it sometimes falls short of other industries in terms of implementation of technological developments. Construction methods have barely changed through the history of the industry, while access to resources and materials has varied significantly in recent years creating the need for change in the management and use of these resources. Technologies such as BIM that promote a more digitally integrated project management system, have gained popularity recently since they allow us to visualize and plan the development of construction projects more efficiently (Kamunda Renukappa S. Suresh S. and Jallow H., 2020; Sarkar & Modi, 2015). (RICS, 2018) published an insight paper in conjunction with Oxford University on Big data, smart cities, intelligent buildings, surveying in a digital world – to equip construction professionals with the insights and tools to be able to consider these issues carefully and act with integrity in an increasingly data-driven world.

Some industries possess a higher success rate in adopting technological developments than others, e.g. the construction industry, which requires more time to make the changes that allow them to keep up with the latest technologies (Silverio-Fernandez, Renukappa, & Suresh, 2019). In the same way, many industries have proven the benefits of adopting Big Data, hence the question arises as to whether these positive results can be replicated in the construction industry. (Ngo, Hwang, & Zhang, 2020), explains that the adoption of BD in construction could produce a great value, but there are no tools to assess the adoption capacity of construction companies.

This research seeks to explore the understanding and applications of Big Data in the Dominican Republic (DR) construction industry. A review of literature was initially conducted to identify the motivation behind the adoption of Big Data in other industries and to create a comparison between the practices in DR’s industry and those presented in the literature. This also served as the basis for formulating the questions used in the data collection through semi-structured interviews. The participants were decision-making representatives of companies that play a leading role in the DR construction industry. The analysis of the data was then performed using thematic analysis, which was used to classify the participants level of awareness of Big Data through an adaptation of the Endsley’s model of Situation Awareness. The results of this analysis are presented and discussed in their respective sections, followed by the conclusion prior to this theoretical background is presented in this paper.

2. THEORETICAL BACKGROUND

The first documented use of the term Big Data (BD) goes back to mid-1990s (Li et al., 2016). Big Data is used to define the big amount of information contained in a database, which due to its heterogeneous characteristics makes it difficult to manage it with traditional data analysis tools (Liu, 2015). In recent years the term has regained popularity as a result of increased production and transmission rate of information that is collected and handled thus gaining the attention of many disciplines and industries to take advantage of the benefits of its implementation (Tamiminia et al., 2020). Many studies (Caesarius & Hohenthal, 2018; Pigni Piccoli G. & Watson R., 2016; The Economist, 2012) agree that the adoption of BD results in positive outcomes such as improved financial performance, business optimization and innovation. (Raguseo, 2018) work highlights the “high revenue” promise as a main driver.

The emerging tools, software’s and gadgets related to different disciplines promotes the adoption of new technologies (Wang et al., 2020). In some countries, adoption of technological developments such as BD occurs more naturally than others. Hence dividing these tendencies in two groups. The first group in most cases adopt the new technology due to government support or incentives or due to industry initiatives, and that as a result exposing the benefits and challenges of adoption. The second group which adopt the new technology after adopting the “wait and see policy” identifying the best practices and lesson learnt from the first group are in a pursuit of the achieving same or more benefits. Still, in both cases, it can be found that some industries are more prone to change than others, and some technological developments can be more easily adopted in some areas than others. The ease with which an industry or discipline adopts a new technology is primarily given by the type of companies that make-up of that industry. In this particular case, industries were most of its companies are data-driven or carried out their operations digitally are more likely to embrace the adoption of new technologies (Caesarius & Hohenthal, 2018; RICS, 2020).

2.1. Big Data Industries Applications

The technological development and exponential grow of information has created the perfect environment for the proliferation of tools that, similar to Big Data, allow to extract useful insights from this data, becoming a determining factor in the decision-making process (Wang et al., 2020).

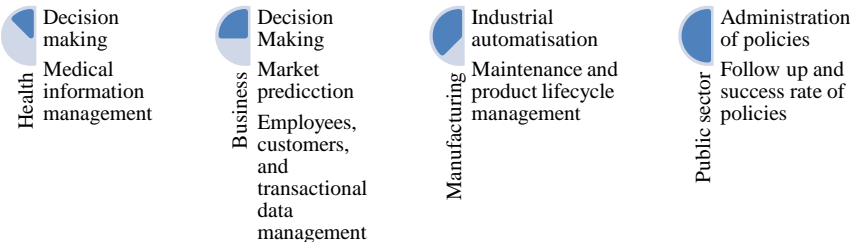


Figure 1: Big Data applications in different industries

As shown in Figure 1, fields such as Healthcare, Public Sector Administration, Business, Manufacturing, among others have taken advantage of the Big Data development wave present in the last couple of years (Rabhi et al., 2019; Tabesh, Mousavidin, & Hasani, 2019; You & Wu, 2019). Many fields have adopted Big Data to substitute their out-dated systems for data management in order to provide a better management and analysis of the high volumes of data that they now produce and possess (Boyd et al., 2020). (Tamiminia et al., 2020), agrees by confirming that the massive volumes of existing geospatial data, its variety of origins and formats, and growing diversity and accessibility, demonstrating how very different fields are motivated by the same aspects in terms of BD adoption. For instance, (You & Wu, 2019) states that the increasing amount of patient data in healthcare formed by information assets with high volume, velocity, value, and diversity through healthcare data resources. The BD

based healthcare information system has been growing rapidly in recent years and is being adapted to derive important health trends and support timely preventive care. Mainly, because the increasing amount of patient data can no longer be handled by the traditional approaches. (You & Wu, 2019), noted that Electronic healthcare records (EHRs), which use big data analytics for major evaluations of diseases and performance of epidemiological analyses. Finally, the decision-making aspect plays a major role in the healthcare industry, therefore the data that propels this process need to be manage with an appropriate tool such as BD.

Other areas such as business and management rely in subjective judgement for decision-making. However, according to (Rabhi et al., 2019) increasingly important decisions are on hard data, which can be obtained through big data analytics. Also, in Human Resources Management, the rate of adoption of Big Data are due to the need of manage large volume of employees, customers, and transactional data in organisations, with the purpose of helping companies to “make decisions and create bigger benefits”. (Wang et al., 2020) acknowledges that, BD application in the manufacturing industrial field is still in its infancy but at the same time, mentions its application in several fields such as natural resource management, industrial automatization and maintenance and Product Lifecycle Management, which are already being developed and applied. Another series of most common applications are presented by (Tabesh et al., 2019), in their study of BD implementation strategies from the administrative point of view (**Error! Reference source not found.**).

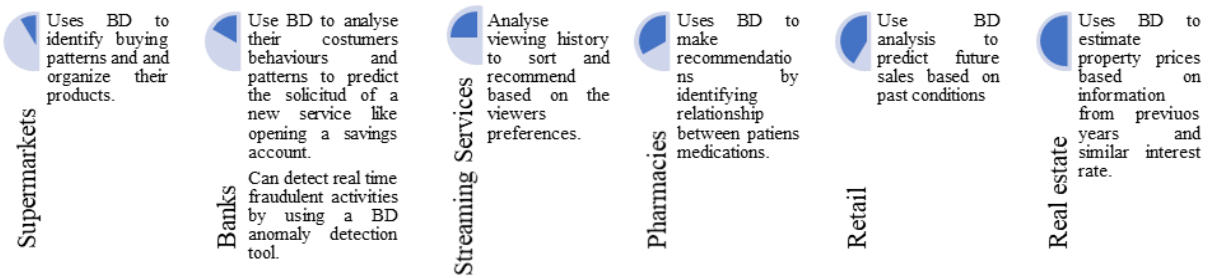


Figure 2: Extract from table "An overview of important big data analytics algorithms and applications"

Source: Tabesh, et. al., 2019.

Big Data has garnered an incredible amount of attention in recent years, this topic has become the focus of conferences and scientific publications all around the world, thus becoming a major innovation source for the academia, causing even a widespread proliferation of research around this topic (Li et al., 2016). Contrary to popular belief that BD is a technology oriented to private industry, the public sector has also started to benefit from its adoption. (Khurshid et al., 2019) indicate that public bodies are one of the producers of data in large quantities such as geo-spatial maps, public records of transfers, appointments, financial statements, census data, and environment datasets. Governments have been actively making available to the public large amounts of data without restrictions creating Big Open Data (BOD) a subcategory of BD that shares its same basic characteristics. Among the applications of this BOD businesses can use this data for commercial purposes, it can allow public to make more informed decisions and the most important thing is that it will provide real-time data for policymaking to deal with intricate situations. Also, the cyclic process of BD analysis (Figure 3) (Rabhi et al., 2019), makes it an ideal tool to follow up on the implementation of those public policies. (Khurshid et al., 2019), also highlight the fact there has been an increase of government uses, for example Pakistan has adopted the use of BOD, based on the need for transparency, follow up of the recent technological developments and development of social and commercial value, among others.

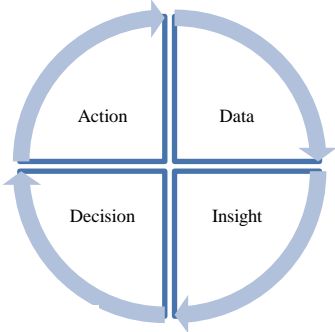


Figure 3: Big Data Analysis Process

2.2. Big Data in Construction

Little is known about the adoption of BD in the construction, since the developments that make possible its use in this industry are still in the early stages (Ngo et al., 2020). Still there is evidence indicating that its adoption within the industry would produce similar results to those obtained in other disciplines. For instance, (Wood, 2018) indicates that the 75% of construction companies already uses cloud storage, which complies with one of the basic aspects of BD which is the creation of the dataset, in the same way, (Burguer, 2019) states that construction related BD exist based on the records that have been kept of all the buildings that have ever been built and that are now digitally storage. Also, these databases continue to grow continuously thanks to the contribution of the digitization of old projects and from sources such as machines, computers, people and others data-generating device from new and current construction projects.

In the same way, (Neilson, Indratmo, Daniel, & Tjandra, 2019), indicated that traffic data complies with all requirements needed to be considered as BD, the information from monitoring equipment and wireless sensors that have been installed to promote safety and traffic monitoring is already being used to gain insights that promotes a more efficient traffic management environment. It also highlights that the projected future of transportation which is the case of autonomous vehicles will depend on real-time traffic data that BD could help to deliver in a more effective way. In the same line, (Chen, Lin, & Wu, 2020), also consider transport as a potential beneficiary of big data adoption, as well as other aspects directly and indirectly related to construction such as monitoring of critical infrastructures and geospatial fields which are used to better locate construction projects (Filipović, Lukić, & Lukić, 2020).

Authors such as (Bilal, M., Oyedele, L.O., Qadir, J., Munir, K., Ajayi, S.O., Akinade, O.O., Owolabi, H.A., Alaka, H.A., Pasha, 2016; Oudjehane Moeini S., 2017), have identified the source of the data available within the construction industry to be considered BD in the form of project schedules, reports, drawings, site images and sensor data as well as information and designs coming from the use of BIM and the use of sensors and technologies related to IOT. In a more recent study, (Ngo et al., 2020) listed the applications of BD in relationship to the project life cycle (**Error! Reference source not found.**), also mentioning the general characteristic of supporting the decision-making processes, which is considered as a general characteristic through of all fields.

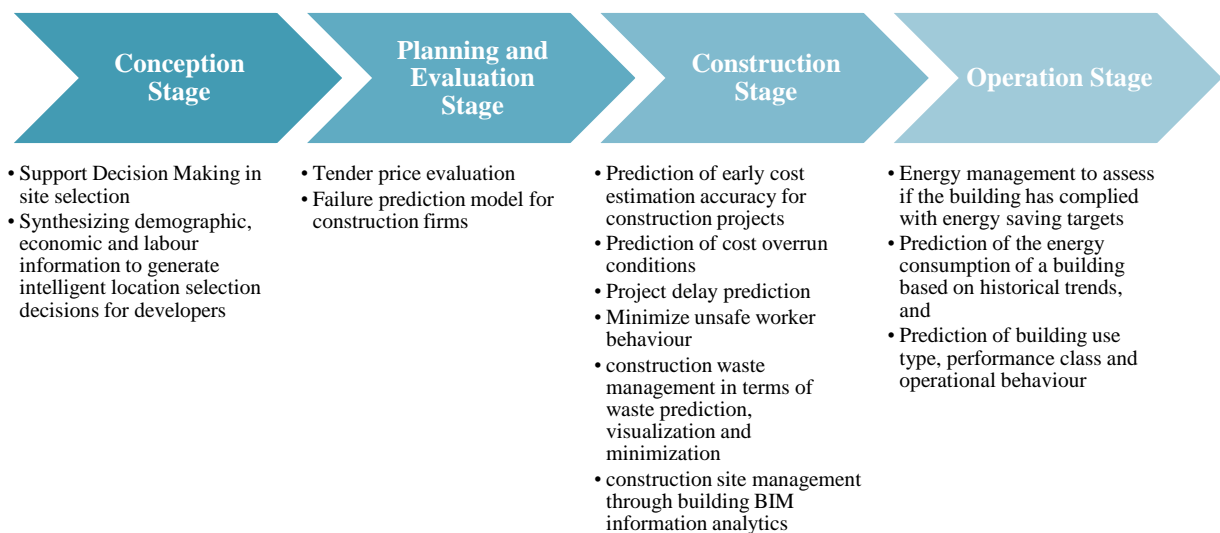


Figure 4: Applications of Big Data in the Construction Project Lifecycle

In accordance with the applications presented above (Burguer, 2019) also indicates that the use of BD in early stages such as design can contribute to a better determination of what and where to build by using not only the modeling and design of the building but also environmental data, stakeholder inputs, social media discussions and historical data which can be used to determine risk probability. An example of this is Brown University in the United States, who used this technology to determine the location of their new building, considering both the benefit of the university and the students. In the same way, traffic, weather and the activity from the surrounding businesses and community can contribute towards the design of the project phasing. During construction, the management of idle time, replenishment of materials and equipment rental and maintenance can be improved,

together with the ability to reduce material waste which represents approximately 25% of the project cost (Carlstrom, 2020). Finally, during the operation stage, the analysis of information coming from the use of sensor on buildings and some infrastructures such as bridges can contribute to the monitoring and managing in the way of energy consumption, operating regulations, detection of uncommon events (Burguer, 2019).

Trends like the “Construction 4.0” which promotes a “connected building site” (Berger, 2016), and technologies currently being implemented such as BIM will allow a better transition to a wide adoption of BD, since it has contributed since its inception to the creation and growth of the construction database through the digitization of designs and processes as well as the incorporation of sensors that generate and transmit construction related data, also the insights extracted from the BD analysis can be used as an input to schedule maintenance in the operating stage of infrastructures for instance. The BIM files of one construction project can easily reach the 100 GB (1024 Bytes) in size (Garyaev & Garyaeva, 2019), and only in the UK, 69% of construction companies were using BIM in their projects according to the National BIM Report (NBS, 2019), which gives an idea of roughly how much data is being generated only by the use of BIM in the construction projects.

2.3. Construction Industry of the Dominican Republic

Just as in the rest of the world, the construction industry plays an important role within Dominican Republic’s economy, contributing 12.2% of the Gross Domestic Product in the form of job and income generation, according to the (Central Bank of the Dominican Republic, 2020) in 2019. The natural phenomena such as earthquakes and the cyclonic season to which the island is subjected during the year requires that the infrastructure be able to withstand the effects of these phenomena placing a special level of responsibility on the Dominican construction industry. The execution of both public and private construction projects with the view to meeting needs in areas such as housing, tourism, and rural development, make this industry one of the main players in the Dominican economy (Silverio-Fernandez et al., 2019).

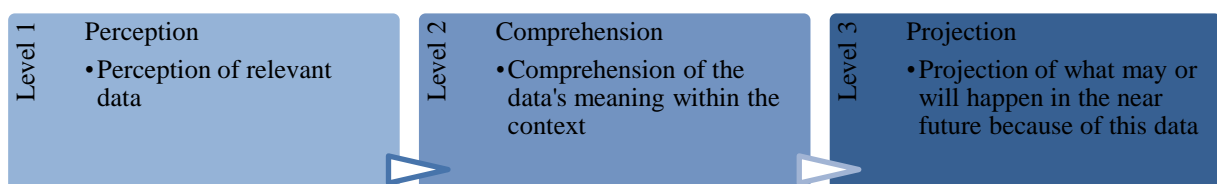
The construction industry is intimately linked to the economic development of the Dominican Republic, from the generation of jobs to the infrastructural development of the nation, such as the improvement of the quality of life through low-cost housing, infrastructure linked to basic necessity services and other factors exposed in the national development strategy (MEPYD, 2017).

In 2019 the Economic Commission for Latin America and the Caribbean (CEPAL), ranked the Dominican Republic with the highest economic growth compared to 2018 in the region (UN, 2019), which suggests that any study carried out in this country could be replicated in others assuming similar conditions in the industry. Consequently, the data collected in this research about the knowledge that the Dominican Decision-makers have about the concept of BD can serve to draw similar conclusions not only in DR but also in other countries of the region and the world.

This document as an extract of a wider investigation about Big Data Implementation in the Dominican Republic’s Construction Industry could help to identify and understand the main challenges faced by the adoption of the BD technology or any other technology that in the same way requires a change in the culture and in the way the industry develops its projects, shifting from the traditional delivery methods to more technological oriented ones driven by the sustainable development of today’s society which demands of less waste, more efficient use of resources and the consideration of social and environmental aspects.

2.4. Measurement of Awareness

In order to “measure” the awareness of BD in DR, Endsley’s “Theory of Situation Awareness” was adopted for this study. This because it is the most generally accepted interpretation of situation awareness, is defined as the “... perception of the elements in the environment within a volume of time and space, the comprehension of their meaning, and the projection of their status in the near future” (M R Endsley, 1995). Based on this model, Situation Awareness Global Assessment technique, which is according to (Dishman, Fallacaro, Damico, & Wright, 2020), considered “the only direct and objective situation awareness measurement tool”. Situational awareness in Endsley’s model has three (3) levels (**Error! Reference source not found.**): perception,



comprehension, and projection (Mica R Endsley & Connors, 2014). For the purpose of this study an adaptation of the Endsley Model was created (**Error! Reference source not found.**). Level zero (0) of “No Awareness” was added.

Figure 5: Endsley original model of Situation Awareness

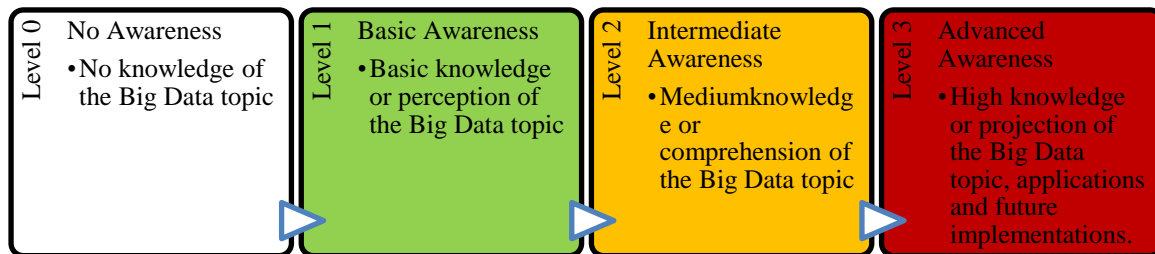


Figure 6: Endsley's Model Adaptation

The concept of Situation awareness (SA) was initially used in military and aviation applications (M R Endsley, 1995). Over the years the application of the SA can be seen across several industries to provide an awareness classification, for instance, disciplines such as health have used Endsley’s model of SA in mental health (Moura et al., 2020). Also, for: thoracic surgery, obstetrics, nursing and anaesthesia (Dishman et al., 2020). Likewise, the program evaluation field used SA to help improve the decision-making skills of program evaluators (Mason, 2020). Manufacturing has also used SA analysis to reduce the incidence of accidents related to forklift driving (Choi, Ahn, & Seo, 2020). However, there is no evidence of this model been applied to Big Data and in particular to the construction industry.

3. RESEARCH SCOPE AND GAP

The first step in understanding the factors that enables the adoption of Big Data in construction is to identify the state of knowledge that is possessed on the subject, which is the scope of this study. It comprises only the general knowledge aspects of the investigation. Representatives from medium and large construction companies in the Dominican Republic were interviewed to assess their level of awareness with questions that explore their understanding about BD using topics related to the Big Data Concept, its characteristics, benefits, data handling and commitment with productivity. This study is limited to analysing concepts related to general knowledge about big data, leaving other aspects also important for implementation such as barriers, challenges, key drivers, etc., for future research.

3.1. Research Gap

Even when there is literature that supports the implementation of Big Data in construction, it recognizes that it is still in its initial stages and that a clear path to adoption has not yet been documented (Ngo et al., 2020). No relevant results were found of the Dominican Republic’s strategies to implement new technologies in apart from (Silverio-Fernandez et al., 2019) but the studies are with respect to smart devices. Therefore, this study seeks to explore the research question: What is the level of awareness about Big Data within the Dominican Republic’s construction industry?

This study will provide an insight into likeminded countries within the region that similar to the Dominican Republic lack documented literature of the adoption of new technologies such as BD. The Dominican Republic plays a major role in the Latin American and Caribbean region with one of the strongest economic growth according to (The World Bank, 2020), reason why any study carried out there could identify a path for other countries in the region to follow.

4. RESEARCH METHODOLOGY

The methodology adopted for this investigation was dictated by data availability (Kumar, 2015), since little to no information exist on the subject, the selected approach to perform this research was qualitative. Semi-structured interviews which are a reliable source of comparable data and let the participants to freely share their points of

view (Cohen D, 2006) was selected as the data collection method. Twenty-one (21) semi-structure interviews were carried out to explore different areas concerning Big Data in the DR Construction industry.

The interviews were directed at large and medium-sized companies with undeniable presence within the productive market and whose representatives (interviewees) were top-level executives involved in their decision-making process.

Table 1: Breakdown of professionals participated in the study

Position	Number of Interviewees
Chief Executive Officer (CEO)	1
Vice-President of Operations	1
Superintendents	2
Seniors	4
Managers	10
Coordinators	3
Total	21

The literature showed that the size of the company influences their ability to implement new technologies such as BD, where the bigger the company the most likely it is able to possess the investment capability and accumulate the amount of data necessary to implement a successful BD analysis (Ngo et al., 2020), this factor determined the sampling technique as non-probabilistic, providing a group of characteristics that both companies and participants should meet to be considered suitable for this study. The size of the company and the position/experience of the interviewee were the factors considered when establishing the sample. The national taxpayer registry of the Dominican Republic was used to identify the construction companies with potential to participate in this research.

The participating construction companies were selected following to the classification according to size provided by the laws of the Dominican Republic (National Congress of the Dominican Republic, 2008), this indicates that the organizations will be classified as:

- Micro: with 1–15 employees, less than RD\$3,000,000.00 in active capital or less than RD\$6,000,000.00 in annual revenue.
- Small: between 16–60 employees, between RD\$3,000,000.01–12,000,000.00 in active capital or between RD\$6,000,000.01–40,000,000.00 in annual revenue.
- Medium: between 61–200 employees, between RD\$12,000,000.01–40,000,000.00 in active capital or between RD\$40,000,000.01–150,000,000.00 in annual revenue.
- Large: with more than 200, more that RD\$40,000,000.00 in active capital or more than RD\$150,000,000.00 in annual revenue.

A total of seventy-eight (78) companies were contacted and asked whether they would be willing to participate in the investigation, a primary response rate of forty-eight-point seven percent (48.7%) was obtained. The results (Table 2) represents the pre-interview process which can be divided in four (4) stages from the moment of the first contact to the interview. Stage I, represents the total of contacted companies, from which thirty eight (38) answers were received Stage II, represents the type of answer received about willingness to participate, nineteen (19) companies responded with definite willingness to participate, fifteen (15) responded with non-definitive interest and the remaining four (4) companies expressed no willingness in participating in the study. Stage III represents the companies to whom all the information related to the study was sent and where another confirmation was requested to schedule the interview appointment. From which twenty-six (26) companies responded with an affirmative answer, one (1) with maybe and other seven (7) decided not to participate. Finally, Stage IV represents, the scheduled interviews, of which twenty-one (21) were conducted from nineteen (19) companies.

Table 2: Pre-Interviewing Process, Willingness to Participate

Stage I	78	Companies Contacted
----------------	-----------	----------------------------

	38	Answered
	40	Not answered
Stage II	38	Answered
	19	Interested
	15	Maybe interested
	4	Not interested
Stage III	34	Answered
	26	Yes, to participate
	1	Maybe to Participate
	7	No, to participate
Stage IV	27	Answered
	19	Did Participate
	8	Not Participate

To determine the number of interviews that would be used for the investigation, the saturation phenomenon was employed. Saturation is a well established method to determine how many interviews are enough in a qualitative study. This term is used to identify the phenomenon where the interviews do not contribute any new or additional information to the investigation (Latham, 2020). (Guest Bunce A. & Johnson L., 2006), in their study reached saturation point in the twelfth interview. In this study, the final sample consisted of twenty-one (21) interviews, from 19 companies. (Crouch & McKenzie H., 2006) states that less than 20 participants in qualitative research helps establish a close relationship and consequently a more reliable exchange of information, identifying the ideal number is between fifteen and twenty (15-20) participants.

Another aspect considered is data generalisation from which conclusions can be drawn from particular situations (Polit & Beck, 2010). As explained earlier in section 3.1 where it is described that due to the economic growth of the Dominican Republic within the Latin America and Caribbean region, it is in an advantageous position and could possibly serve as an example regarding the implementation of new technologies such as BD.

The data collection process lasted from October 2019 to March 2020 and were held in Santo Domingo, Dominican Republic. The interviews were capture using voice recordings and the duration was between nine (9) and twenty-two (22) minutes approximately. Each interview was transcribed and then translated into English from Spanish, which is the official language of the Dominican Republic, except one was in English language with the prior approval of the interviewee.

4.1.Data Analysis

The analysis method adopted is thematic analysis. This study aims to explore the awareness and understanding of the participants about BD. An assessment of the level of awareness was performed covering key aspects such as concept, characteristics, benefits, data handling and commitment with productivity related to adoption of new technologies.

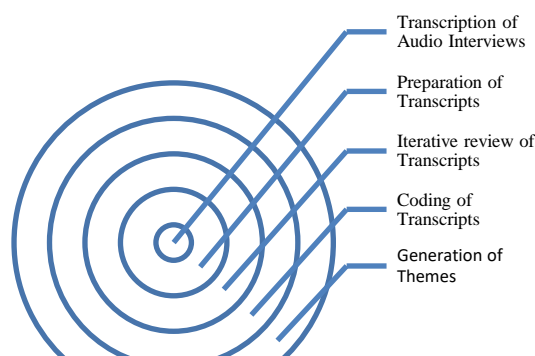


Figure 7: Creswell’s Data Analysis Process described in “Guide for Qualitative Data Analysis”

In preparation for the data analysis part of a process described by Creswell in its “Guide for Qualitative Data Analysis” (Figure 7) was considered. As (Creswell, 2013) describes five steps that were used to prepare the interviews for the analysis process. The three (3) first steps were applied to the data collected as preparation for the analysis.

The data analysis process of coding and generation of themes was performed using the program Microsoft Excel, each code was placed in a cell, thus creating a grid containing a classification according to the coding assigned to each question and each interview (Caulfield, 2019). This classification represents the levels of awareness about the Big Data within the Endsley model (Figure 6). Furthermore, the individual results according to each question are presented to visualize awareness in each specific area represented by the questions.

5. FINDINGS

In this study, during face-to-face interviews, in order to capture the level of awareness on the concept of “Big Data”, a question was raised, i.e. what is your level of awareness of “Big Data” concept? Overall, interviewee’s awareness on the BD concept were distributed between various levels of the situational awareness in the modified Endsley’s model. Of the interviewees, 33% (7 of the 21) noted that ‘no awareness’ or never heard of the Big Data concept and its relationship within the construction industry. This reflects on the no awareness Level 0 of the Endsley’s model. For instance, interviewee I₈ highlighted that:

“No, I had not really heard the term until this moment”.

It is evident from the above statement that, the DR construction organisations lacks basic understanding of the concept of Big Data. Therefore, to improve the DR construction industry competitiveness, decision makers have to recognise and understand the concept of Big Data. It is worthwhile to consider a holistic impact of Big Data concepts to improve the project delivery processes of the DR construction industry.

33% (7 of the 21) of the interviewees had ‘basic awareness’ on the concept of Big Data and are at Level 1. This reflects on the basic awareness Level 1 of the Endsley’s model. For instance, interviewee I₂₀ highlighted that:

“Very generally, a big database that can be used to identify trends and to manage information”.

Similarly, I₁₂, stated that:

“I’ve heard of the term applies to statistics and economy, but I never hear of any relationship of BD and Construction”.

From the above, it is evident that there is a basic awareness of what BD is but not in relation to the construction industry. Therefore, there is a need to raise awareness of Big Data concepts and applications in the context of construction industry. It is evident that 66% of the interviewees (14 of the 21) lacks the basic understanding of the concept of BD and its relevance to the construction industry. Therefore, there is a need to develop a continuous professional development programme for the benefit of present construction professional in the DR.

Of the interviewees, 29% (6 of the 21) noted that they have an ‘intermediate awareness’ on the concept of Big Data. This reflects on the intermediate awareness Level 2 of the Endsley’s model. For example: I₄ and I₁₁ noted that

“BD in relation with the construction industry is about the amount of data created in a construction project”. – I₄

“From what I understand is that this technology allows you to extract insights of data from past projects in order to make better decisions in the management of the future projects” – I₁₁

It is evident that there is an intermediate level of awareness in terms of the applications of BD in the construction industry, but the interviewees were not involved in the implementation of the BD concept. Therefore, it is important to document and provide BD leadership awareness programmes that include the holistic approach for implementing BD in construction industry.

Whereas just 5% (1 of the 21) interviewees noted that they have an 'advanced awareness'. This reflects on the advanced awareness Level 3 of the Endsley's model. The interviewee I₅ noted that:

"I knew the term Big Data, actually last year because I used a software for data analytics as it is a big corporation, they have like two departments, one for construction and one that's like a supplier. The operation manager used information for the statistics of the sales which quarter of the year make the most xxxx, in comparisons with this year and the last year. As well as the construction department saw how they used the information. As a big corporation, more data is gathered on a continuous basis. Therefore, I had to learn what Big Data is and how to manage Big Data and apply it to provide trend analysis and enhance decision making".

6. DISCUSSION

The need to manage increasing data volumes that is been produced today is the major key driver for many industries that have already been making inroads in the adoption of Big Data and data management technology for years (Tamiminia et al., 2020; You & Wu, 2019), phenomenon that undoubtedly also occurs within the construction industry. Plenty of literature exist reflecting on the positive results of adoption BD in other disciplines (Caesarius & Hohenthal, 2018; Pigni Piccoli G. & Watson R., 2016; Raguseo, 2018; Tamiminia et al., 2020; The Economist, 2012), while limited sources exists about Big Data adoption within the construction industry indicating the presence of a gap. Still, areas such as project waste management, energy efficiency, project planning are already benefiting from BD implementation, driven by the use of technologies and trends such as BIM and Construction 4.0, which also contribute to the growth of BD datasets through the promotion of cloud storage and the use of data generating equipment in construction (Berger, 2016; Burguer, 2019; Wood, 2018).

This study represents the first step towards the adoption of Big Data within construction and was carried out by assessing the level of awareness that main characters, on which a future BD implementation in construction will depend, possess of the topic. The results revealed the awareness state of the industry when it comes to Big Data, showing overall, that there is a basic level of awareness prevailing within this field, meaning that an in-depth and industry-wide adoption of the subject is required to ensure a homogeneous implementation of the technology.

Surprisingly, the results demonstrated that the concept of big data, is generally known in the Dominican Republic's industry, which agrees with much of the literature indicating that in recent years there has been an exponential increase in the use of both the term and the technology (Wang et al., 2020). But at the same time there is a lack of understanding about the possible connection between BD and construction, identifying this as the main challenge. Since most of the participants that did know about the technology were unaware of its applications in the industry. On the other hand, the literature shows that the basic elements for data accumulation and transmission in the form of cloud storage and data-generating and transmitting devices, are already widely used in the world industry being Dominican Republic no exception (Burguer, 2019; Wood, 2018) even when they haven't been recognised as such or put in place for BD purposes.

The accumulation of large volumes of data is the main driver for the implementation of BD in most industries (Boyd et al., 2020), the industry-wide adoption of BIM, which contribute more than 100GB of data in each project, represents a great input to the creation of BD databases that can be used for analysis and the extraction of insights that can improve decision-making and the generation of necessary feedback processes (Garyaev & Garyaeva, 2019). In contrast, the inherent resilience of the construction industry to implement new technologies that do not have a high and proven success factor plays against any move towards implementation (Ngo et al., 2020). Thus, indicating that overcoming this is a primary aspect to develop for a successful adoption of Big Data and any new technology.

The findings of this research will allow researchers and managers to be aware, and at the same time, understand that at this moment the main barrier for the adoption of Big Data is the lack of concept generalization, as well as the lack of understanding about the tools necessary to manage the data. This could potentially help to react accordingly, in order to minimize those obstacles at the time of implementation. Also, this study could serve as a base of knowledge and a drive to a better awareness of the technology and its benefits together with the understanding of what is being done and what is still needed to adopt BD as part of the construction industry culture of project deliverance, at the end, the benefits of transparency, efficiency, better decision-making are the main assets required to meet the needs of today's society.

7. CONCLUSION

The adoption of Big Data has become a primary goal for most industries across the world, driven by the exponential increase in data generation and the proliferation of data generating elements that seek to facilitate the management of operations both within companies and in daily life. In the same way it has been shown that the construction industry on many occasions lags in the adoption of new technological developments such as BD. While the creation of large volumes of data that have led to the expansion of this technology through different industries will continue to grow along with technological developments, thus it is necessary that industries like construction take advantage of the opportunities offered by this type of tools.

The use of Big Data Analysis has proven to offer a wide variety of benefits such as improvement of decision-making, process efficiency, and improvements in transparency and communication within the industries in which it has been implemented. For the construction industry it could help with the reduction of project waste hence lowering costs, managing the sustainability requirements of projects, improve planning and project deliverance to mention a few.

As a first step towards the adoption of BD in construction, this study sought to determine the level of awareness about BD that representatives within the decision-making level of construction companies possess, with the purpose of identifying the challenges and barriers that needed to be overcome to could facilitate a future implementation of the technology across the whole sector. Situation awareness was selected since it is a main element of the decision-making process. The assessment of the level of awareness of BD served to identify the strategies that could facilitate path for an industry-wide implementation.

The data analysis was carried out applying a modification of the Endsley model, which served to qualify the answers obtained in the semi-structured interview. Four levels of awareness were identified ranging from level 0 or no awareness, to level 3 or advance awareness. The results showed that although there is a relatively high level of knowledge about the BD concept, there is also a high level of ignorance about the basic steps of data management and BD applications in relation with the construction industry. The first is important because it is the foundation of the dataset creation necessary to promote a BD analysis, and the latter because it could boost the interest of investors and start an industry-wide implementation of the BD technology.

This paper provides a richer insight into the understanding of awareness and how it could be used to explore topics related to the implementation of new technologies. This study contributes towards the understanding of what are the first steps towards Big Data adoption and to provide a source that can be used to inform current and future professionals about a technology that will certainly be relevant in the near future of the construction industry.

This study could be further extended by exploring other barriers, challenges, key motivators and opportunities presented by big data adoption, taking other industries as an example. Future studies could also explore the level of awareness in other settings like more developed countries in order to determine if this factor influences the adoption of new technologies. In the same way, a study of the financial performances of companies that have implemented BD across all industries to demonstrate if the BD benefits vary depending on the type of organisation.

This study is limited to analysing concepts related to general knowledge about big data, and its results apply within the framework of the construction industry of the Dominican Republic, although the results may be applicable to other countries with similar conditions. Other key aspects for implementation as well as exploration within the framework of other countries can be used as the objectives of future research.

Finally, the implications of this study are to the professional involved in the digital process and decision-makers in the construction industry. Also, to the construction-oriented education sector to provide didactic tools to better prepare future professionals, similarly to provide continuous improvement training to achieve a standardised level of awareness of BD for the current construction professionals.

8. REFERENCES

- Berger, R. (2016). Digitization in the construction industry. *Roland Berger GmbH*, 16. Retrieved from https://www.rolandberger.com/publications/publication_pdf/tab_digitization_construction_industry_e_final.pdf
- Bilal, M., Oyedele, L.O., Qadir, J., Munir, K., Ajayi, S.O., Akinade, O.O., Owolabi, H.A., Alaka, H.A., Pasha, M. (2016). Big Data in the construction industry: a review of present status, opportunities, and future trends, *30*,

- Boyd, D., Crawford, K., Caesarius, L. M., Hohenthal, J., Caulfield, J., Chen, P.-T., ... Ahmad, M. N. (2020). Searching for big data. *Accident Analysis & Prevention*, 43(1), 35–43. <https://doi.org/10.1016/j.compeleceng.2019.07.010>
- Burguer, R. (2019). How the Construction Industry is Using Big Data. Retrieved from <https://www.thebalancesmb.com/how-the-construction-industry-is-using-big-data-845322>
- Caesarius, L. M., & Hohenthal, J. (2018). Searching for big data: How incumbents explore a possible adoption of big data technologies. *Scandinavian Journal of Management*, 34(2), 129–140. <https://doi.org/10.1016/j.scaman.2017.12.002>
- Carlstrom, C. (2020). How big data is impacting the construction industry. *QFlow*.
- Caulfield, J. (2019). How to do thematic analysis.
- Central Bank of the Dominican Republic. (2020). *Gross Domestic Product (GDP) by the spending approach. Current values and chained volume indices referenced to 2007-2019, quarterly. March 2020.*
- Chen, P. T., Lin, C. L., & Wu, W. N. (2020). Big data management in healthcare: Adoption challenges and implications. *International Journal of Information Management*, 53(December 2019), 102078. <https://doi.org/10.1016/j.ijinfomgt.2020.102078>
- Choi, M., Ahn, S., & Seo, J. (2020). VR-Based investigation of forklift operator situation awareness for preventing collision accidents. *Accident Analysis & Prevention*. <https://doi.org/https://doi.org/10.1016/j.aap.2019.105404>
- Cohen D, C. B. (2006). Semi-structured Interviews. Retrieved from <http://www.qualres.org/HomeSemi-3629.html>
- Creswell, J. W. (2013). *Research Design: Qualitative, Quantitative, and Mixed Methods Approaches*. Thousand Oaks, CA.: Sage publications.
- Crouch & McKenzie H., M. (2006). The logic of small samples in interview-based qualitative research. *Social Science Information*, 45(4).
- Dishman, D., Fallacaro, M. D., Damico, N., & Wright, M. C. (2020). Adaptation and Validation of the Situation Awareness Global Assessment Technique for Nurse Anesthesia Graduate Students. *Clinical Simulation in Nursing*. <https://doi.org/https://doi.org/10.1016/j.ecns.2020.02.003>
- Endsley, M R. (1995). Measurement of situation awareness in dynamic environments Human Factors. *Human Factors*, 37(1), 65–84.
- Endsley, Mica R, & Connors, E. S. (2014). Chapter 30 - Enhancing Situation Awareness in Power Systems: Overcoming Uncertainty and Variability with Renewable Resources. In L. E. B. T.-R. E. I. Jones (Ed.) (pp. 381–390). Boston: Academic Press. <https://doi.org/https://doi.org/10.1016/B978-0-12-407910-6.00030-2>
- Filipović, D., Lukić, A., & Lukić, M. (2020). Geospatial Evaluation of Belgrade for the Purposes of Determination of Suitable Locations for the Construction of Pv Plants. *Archives for Technical Sciences*, 1(22). <https://doi.org/10.7251/afts.2020.1222.059f>
- Garyaev, N., & Garyaeva, V. (2019). Big data technology in construction. *E3S Web of Conferences*, 97. <https://doi.org/10.1051/e3sconf/20199701032>
- Guest Bunce A. & Johnson L., G. (2006). How many interviews are enough? An experiment with data saturation and variability. *Field Methods*, 18(1), 24.
- Kamunda Renukappa S. Suresh S. and Jallow H., A. (2020). BIM in the Water Industry: Addressing Challenges to improve the project delivery process, Engineering, Construction and Architectural Management (ECAM). *Special Issue: Construction 4.0*.
- Khan, R. A. (2008). Role of Construction Sector in Economic Growth: Empirical Evidence from Pakistan Economy. In *First International Conference on Construction In Developing Countries (ICCIDC-I)*

- “*Advancing and Integrating Construction Education, Research & Practice* (Vol. 7). Karachi, Pakistan. <https://doi.org/10.4314/fje.v7i1.4>
- Khurshid, M. M., Zakaria, N. H., Rashid, A., Kazmi, R., Shafique, M. N., & Nazir Ahmad, M. (2019). Analyzing diffusion patterns of big open data as policy innovation in public sector. *Computers and Electrical Engineering*, 78, 148–161. <https://doi.org/10.1016/j.compeleceng.2019.07.010>
- Kumar, R. (2015). Research Methodology: A Step-by-Step Guide for Beginners. *American Journal of Industrial and Business Management*, 5(5).
- Latham, J. (2020). Qualitative Sample Size – How Many Participants is Enough? *John Latham*. Retrieved from <https://www.drjohnlatham.com/many-participants-enough/>
- Li, S., Dragicevic, S., Castro, F. A., Sester, M., Winter, S., Coltekin, A., ... Cheng, T. (2016, May 1). Geospatial big data handling theory and methods: A review and research challenges. *ISPRS Journal of Photogrammetry and Remote Sensing*. Elsevier B.V. <https://doi.org/10.1016/j.isprsjprs.2015.10.012>
- Liu, P. (2015). A survey of remote-sensing big data. *Frontiers in Environmental Science*, 3, 45. Retrieved from <https://www.frontiersin.org/article/10.3389/fenvs.2015.00045>
- Mason, S. (2020). Practice makes better? Testing a model for training program evaluators in situation awareness. *Evaluation and Program Planning*. <https://doi.org/https://doi.org/10.1016/j.evalprogplan.2020.101788>
- MEPYD, M. D. E. P. Y. D. de la R. D. (2017). *MEPYD Cuarto Informe Anual de Avance en la Implementacion de la Estrategia Nacional de Desarrollo 2030 y Cumplimiento de los Objetivos y Metas del Plan Plurianual del Sector Publico 2015*.
- Moura, I., Teles, A., Silva, F., Viana, D., Coutinho, L., Barros, F., & Endler, M. (2020). Mental health ubiquitous monitoring supported by social situation awareness: A systematic review. *Journal of Biomedical Informatics*. <https://doi.org/https://doi.org/10.1016/j.jbi.2020.103454>
- National Congress of the Dominican Republic. Law No. 488-08 (2008). Santo Domingo, Distrito Nacional.
- NBS. (2019). *National BIM Report 2019. National BIM Report 2019 :The definitive industry update*. <https://doi.org/10.1017/CBO9781107415324.004>
- Neilson, A., Indratmo, Daniel, B., & Tjandra, S. (2019, September 1). Systematic Review of the Literature on Big Data in the Transportation Domain: Concepts and Applications. *Big Data Research*. Elsevier Inc. <https://doi.org/10.1016/j.bdr.2019.03.001>
- Ngo, J., Hwang, B. G., & Zhang, C. (2020). Factor-based big data and predictive analytics capability assessment tool for the construction industry. *Automation in Construction*, 110(November 2019), 103042. <https://doi.org/10.1016/j.autcon.2019.103042>
- Oudjehane Moeini S., A. (2017). Big Data in Construction Projects: Risk and Opportunity Management.
- Pigni Piccoli G. & Watson R., F. (2016). Digital data streams: Creating value from the real-time flow of big data. *California Management Review*, 58(3), 5–25.
- Polit, D. F., & Beck, C. T. (2010). Generalization in quantitative and qualitative research: Myths and strategies. *International Journal of Nursing Studies*. <https://doi.org/https://doi.org/10.1016/j.ijnurstu.2010.06.004>
- Rabhi, L., Falih, N., Afraites, A., & Bouikhalene, B. (2019). Big Data Approach and its applications in Various Fields: Review. In *Procedia Computer Science* (Vol. 155, pp. 599–605). Elsevier B.V. <https://doi.org/10.1016/j.procs.2019.08.084>
- Raguseo, E. (2018). Big data technologies: An empirical investigation on their adoption, benefits and risks for companies. *International Journal of Information Management*, 38(1), 187–195. <https://doi.org/10.1016/j.ijinfomgt.2017.07.008>
- RICS. (2018). Big Data, Smart Cities, Intelligent Buildings – Surveying in a Digital World. *Royal Institution of Chartered Surveyors*, (March), 1–24. Retrieved from <https://www.rics.org/globalassets/rics->

website/media/knowledge/research/insights/big-data-smart-cities-intelligent-buildings-surveying-in-a-digital-world-rics.pdf

- RICS. (2020). The Futures Report 2020, 11. Retrieved from <https://www.rics.org/globalassets/rics-website/media/news/news--opinion/rics-future-report-2.pdf>
- Sarkar, D., & Modi, R. (2015). Applications of Building Information Modeling (BIM) to Real Estate Projects of Ahmedabad. *International Advanced Research Journal in Science, Engineering and Technology*, 2(9), 54–58. <https://doi.org/10.17148/IARJSET.2015.2911>
- Silverio-Fernandez, M. A., Renukappa, S., & Suresh, S. (2019). Evaluating critical success factors for implementing smart devices in the construction industry: An empirical study in the Dominican Republic. *Engineering, Construction and Architectural Management*, 26(8), 1625–1640. <https://doi.org/10.1108/ECAM-02-2018-0085>
- Sitsabo Dlamini. (2012). Relationship of Construction Sector to Economic Growth. *International Congress on Construction Management Research*, 213–225. Retrieved from https://www.irbnet.de/daten/iconda/CIB_DC25593.pdf
- Tabesh, P., Mousavidin, E., & Hasani, S. (2019). Implementing big data strategies: A managerial perspective. *Business Horizons*, 62(3), 347–358. <https://doi.org/10.1016/j.bushor.2019.02.001>
- Tamiminia, H., Salehi, B., Mahdianpari, M., Quackenbush, L., Adeli, S., & Brisco, B. (2020). Google Earth Engine for geo-big data applications: A meta-analysis and systematic review. *ISPRS Journal of Photogrammetry and Remote Sensing*, 164, 152–170. <https://doi.org/10.1016/j.isprsjprs.2020.04.001>
- The Economist. (2012). Big data: Crunching the numbers. Special report on international banking. *The Economist*.
- The World Bank. (2020). *World Bank open data*.
- UN, U. N. (2019). *Balance Preliminar de las Economías de America Latina y el Caribe*. Santiago, CL: United Nations.
- Wang, Y., Wang, S., Yang, B., Zhu, L., & Liu, F. (2020). Big data driven Hierarchical Digital Twin Predictive Remanufacturing paradigm: Architecture, control mechanism, application scenario and benefits. *Journal of Cleaner Production*, 248. <https://doi.org/10.1016/j.jclepro.2019.119299>
- Wood, M. (2018). *The landscape of Construction IT Decision Making. Fonthill Recovered*. <https://doi.org/10.2307/j.ctv1xz0t0.14>
- You, Z., & Wu, C. (2019). A framework for data-driven informatization of the construction company. *Advanced Engineering Informatics*, 39, 269–277. <https://doi.org/10.1016/J.AEI.2019.02.002>

FACILITATING INFORMATION EXCHANGE FOR 3D RETROFIT MODELS OF EXISTING ASSETS USING SEMANTIC WEB TECHNOLOGIES

Farhad Sadeghineko

Department of Construction and Surveying, Glasgow Caledonian University, Glasgow G4 0BA, United Kingdom, farhad.sadeghineko@gcu.ac.uk

Bimal Kumar

Department of Architecture and Built Environment, Northumbria University, Newcastle upon Tyne NE1 8ST, United Kingdom, bimal.kumar@northumbria.ac.uk

Abstract: Building Information Modelling (BIM) has gained a lot of momentum in new building projects in Architecture, Engineering, and Construction (AEC) for varying purposes like design, construction as well as Asset/Facilities Management (AM/FM). However, its use in existing buildings has been hampered by the challenges surrounding the limitations of available technologies used for generating retrofit models. In recent years, 3D laser scanning technology, as a remote sensing technique, has been extensively used to collect geometrical data from existing buildings. The output of this technology is a set of three-dimensional point measurements, also known as Point Cloud Data (PCD). In current practice, PCD is analysed and processed manually to generate BIM models utilising commercial BIM-driven platforms. Accordingly, several studies have been undertaken, proposing semi-automated approaches for generating parametric models by using PCD as the primary geometrical data source. An appropriate 3D model that is fit for purpose for a BIM-based process of design, construction, as well as operation and maintenance (O&M) of assets should incorporate geometrical and non-geometrical data. While the geometrical data can be extracted from the collected data, non-geometrical data may need to be appended to this for generating a genuinely semantically rich BIM model. On the other hand, a reliable data exchange framework could be beneficial within the AEC industry for O&M purposes. In this regard, a data exchange framework structured based on the Linked Data principles could be promising for creating a unified data format which would enhance the process of data exchange accordingly. This paper first outlines a framework proposed for generating semantically enriched 3D retrofit models for existing buildings by utilising the Resource Description Framework (RDF). RDF is utilised as a unified data format in the proposed framework to aggregate data captured from distributed offline and online data sources. The model, containing geometrical and non-geometrical data, is then generated through the conversion of RDF into IFC data model. However, the main focus of this paper is to propose a data exchange framework for populating the RDF data generated through the previously mentioned approach by using existing linked data schemas and vocabularies, such as Web Ontology Language for ifc (ifcOWL), Building Ontology Topology (BOT), Ontology for Managing Geometry (OMG), etc.

KEYWORDS: Building Information Modelling (BIM), Point Cloud Data (PCD), Information Exchange, Semantic Web Technologies, Resource Description Framework (RDF), Industry Foundation Classes (IFC), Web Ontology Language (OWL).

1. Introduction and Background

The use of BIM process has lately gained a lot of momentum within the Architecture, Engineering, and Construction (AEC) (Volk, Stengel, & Schultmann, 2014). In the construction industry, BIM process has been utilised for various purposes, such as Asset/Facilities Management (AM/FM), renovation, and heritage restoration and preservation (Volk et al., 2014; Barazzetti, 2016). The use of BIM process is beneficial for improving different aspects of a building's life-cycle, such as the decision-making process and the precision of the design during the planning stage, quality of the product, management and exchange of information, energy efficiency, sustainability, and health and safety (Hayne, Kumar, & Hare, 2014; Sadeghineko, Kumar, & Chan, 2018). BIM models are one of the essential subsections of the BIM process. The information embedded in BIM models is used throughout a BIM-enabled asset life-cycle to facilitate the performance of Operation and Maintenance (O&M) (Klein, Li, & Becerik-Gerber, 2012), exchange of information about a facility (Tang, Huber, Akinci, Lipman, & Lytle, 2010), and energy analysis and simulation (Wang, Cho, & Kim, 2015). BIM models are also used to facilitate the design visualisation of an asset, estimation of material and cost,

monitoring the condition of an asset, integration of design and fabrication, and incorporating supplementary information and knowledge into BIM models. Moreover, the exchange – storing, sharing, and reusing – of information embedded in BIM models is vitally crucial for taking full advantage of models in BIM-driven projects (Kumar, 2016).

While the use of BIM has gained a lot of interest in new building projects, its use in existing and retrofit buildings has been hampered by the challenges and limitations of related technologies (Barazzetti, 2016; Thomson & Boehm, 2015). Different data collection techniques, such as image-based (e.g. Photogrammetry and Videogrammetry) and range-based (e.g. 3D Laser Scanning) surveying technologies, are utilised to collect the data of an asset in the form of images and three-dimensional point measurements also known as Point Cloud Data (PCD) (Oliver, Seyedzadeh, Rahimian, Dawood, & Rodriguez, 2020). 3D laser scanning technology has been extensively used to collect geometrical data from existing buildings, and PCD is the output of this technology. PCD is used for various purposes like tracking & monitoring construction progress, capturing the actual as-built condition of a facility, health and safety on construction sites, energy efficiency, and generating parametric 3D models (Pour Rahimian, Seyedzadeh, Oliver, Rodriguez, & Dawood, 2020; Hayne et al., 2014; Seyedzadeh, Rahimian, Oliver, Glesk, & Kumar, 2020).

In current practice, PCD is used to generate building geometries in BIM-driven platforms manually, which is considered as a time-consuming, tedious, labour intensive, and error-prone process (Son & Kim, 2016). Hence, several studies have been carried out to develop and propose approaches for changing the manual process of generating BIM models into an automated or semi-automated process by utilising PCD as the primary geometrical data source (Thomson & Boehm, 2015). This process is also known as Scan-to-BIMs method. Technically, the result of such approaches is not a full-blown BIM model as usually understood (Volk et al., 2014; Thomson & Boehm, 2015). The fact is that an appropriate parametric model that is fit for purpose for a BIM-based process of design, construction and O&M of assets should incorporate geometrical and non-geometrical data (Sadeghineko & Kumar, 2020; Volk et al., 2014). In a BIM-enabled project, one of the main reasons behind the generation of a semantically enriched 3D model is to improve the information exchange and interoperability throughout the building's life-cycle (Curry et al., 2013). While the geometrical properties can be extracted from a PCD, non-geometrical data, such as O&M-related data (e.g. Residual Risks, Sustainability Performance, Expected Life, and Risks), may need to be appended to the 3D model for generating a genuinely semantically enriched 3D model. In current practice, approaches proposed and developed in the literature mainly focus on the detection of geometries in PCD rather than the information required in BIM models (Volk et al., 2014).

The Industry Foundation Classes (IFC) data model and the Construction Operation Building information exchange (COBie) data format are examples of information exchange standards within the AEC industry. COBie is a spreadsheet (.xlsx) data format that includes information about different aspects of an individual building, such as type, location, make, tag, serial number, and installation information of building elements. It is mainly used in AM/FM domains for O&M purposes and not for exchanging information between BIM-driven applications (Farias, Roxin, & Nicolle, 2015; Volk et al., 2014). The IFC data model, on the other hand, is an open-source data model developed by buildingSMART International (bSI). It is the most well known and commonly utilised information exchange standard between BIM-driven applications within the AEC industry (Pauwels et al., 2011; Kumar, 2016). However, due to some of the limitations and implications of IFC data model (Uggla & Horemuz, 2018; Molinero Sánchez, Gómez-Blanco Pontes, & Rivas López, 2019) on capturing all kinds of non-geometrical data, commercial BIM software largely suffer from the limitations of exchanging data and indirectly capturing semantically enriched 3D models of existing assets. In real-world projects, the information that cannot be appended to the BIM models is inevitably stored in different data formats outside the model which makes data manipulation, information exchange and interoperability processes ineffective and inefficient (Sadeghineko & Kumar, 2020).

Various schemas like ifcOWL (Pauwels & Terkaj, 2016), ifcJSON (Afsari, Eastman, & Castro-Lacouture, 2017), and COBieOWL (Farias et al., 2015) have been developed as a second alternative schema for distributing data on the Web effectively and efficiently by using semantic web technologies. However, they are not designed to generate BIM models and available BIM applications do not support such schemas currently (Volk et al., 2014; Sadeghineko & Kumar, 2020). For example, ifcOWL is predominantly created from an existing IFC data model by converting IFC into OWL (Web Ontology Language) ontology by the implementation of IFC-to-RDF (Pauwels et al., 2011) and EXPRESS-to-OWL (Pauwels & Terkaj, 2016) algorithms. The process of developing such schemas mainly commences from an existing building model, which may or may not incorporate geometrical and non-geometrical data. In terms of information exchange, different ontologies like Building Topology Ontology (BOT) and Ontology for Managing Geometry (OMG) have been developed by World Wide Web Consortium (W3C) Linked Building Data Community Group (W3C LBD-

CG) for storing and sharing data. BOT is a modular building ontology developed for expressing the topology of a building (e.g. Site, Building, Space, Building Element, etc.), and OMG has been developed for facilitating the reuse of linked geometry descriptions of an object on the Web (Rasmussen, Pauwels, et al., 2017; Terkaj, Schneider, & Pauwels, 2017).

An approach has been developed in Sadeghineko & Kumar, 2020 to address the challenges and limitations involved in generating BIM models from PCD. The proposed framework focuses on the generation of semantically enriched 3D retrofit models from PCD by utilising Resource Description Framework (RDF) as semantic web technology and standard. This paper outlines the proposed framework before proposing the approach for facilitating the information exchange for existing assets by utilising existing building ontologies.

2. Related work

2.1. Parametric modelling utilising Point Cloud Data (PCD)

An existing building may not have a 3D as-designed model or indeed any model at all. In such cases, 2D drawings and paper-based or digital documents are the only available information sources for generating BIM models (Sadeghineko et al., 2018; Sadeghineko, Kumar, & Chan, 2019). In this case, the procedure of generating BIM models is implemented through a Scan-to-BIMs process by directly utilising PCD as the primary geometrical data captured from an asset (Thomson & Boehm, 2015). PCD is widely used in the AEC industry to generate parametric models manually by using commercial BIM platforms. Therefore, various approaches have been proposed in the literature to move from the traditional and manual process of generating parametric models towards an efficient and effective automated or semi-automated procedure. Geometric attributes, such as linear, planar patches (surfaces), 3D primitives, and volumetric characteristics, are employed in proposed methods to declare automated or semi-automated procedures with varying success (Tran, Khoshelham, Kealy, & Díaz-Vilariño, 2018; Thomson & Boehm, 2015). The Scan-to-BIMs process is generally implemented through several steps, viz. the collection of data in the form of PCD, PCD registration, PCD segmentation, and the generation of building elements (Figure 1).

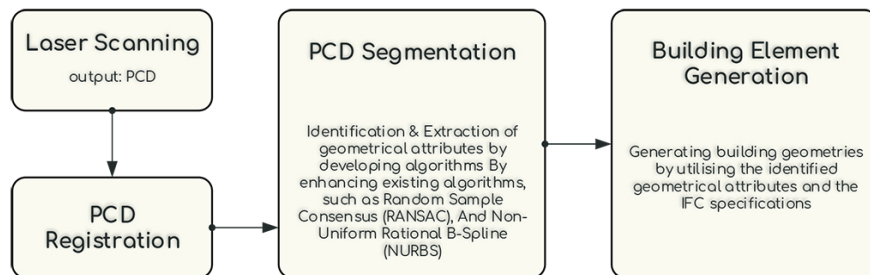


Fig. 1: The general process of capturing building elements from PCD, also known as Scan-to-BIMs.

The work carried out by Zhang, Vela, Karasev, & Brilakis, 2015 focus on the reconstruction of building elements in various real-world projects. Different data collection technologies, such as image- and range-based methods, are utilised to collect the data from existing buildings in the form of PCD. The main focus of this method is the identification of planar surfaces in the PCD due to the importance of planar patches in shaping 3D geometries and primitives (Dore & Murphy, 2015). A variety of different existing algorithms, such as unsupervised subspace learning technique, Maximum Likelihood Estimation Sample Consensus (MLESA), Singular Value Decomposition (SVD) procedure, and α -shape algorithm, is utilised to generate building elements from PCD. These techniques are widely adopted in the computer science domains like image processing for extracting and classifying linear features embedded in collected data. A segmentation algorithm declared based on the unsupervised subspace technique is utilised to retrieve linear relationships between elements in PCD. This technique is employed to identify the number of linear relationships, associated dimensions, and segmentation groups of points in PCD. The MLESA and SVD methods are then applied to calculate and extract plane models from the PCD. The α -shape algorithm is lastly used to extract the corresponding planar patches (surfaces) from the PCD as the final output of this approach. Another example of generating building elements through the Scan-to-BIMs process can be the work undertaken by Thomson & Boehm, 2015 focusing on the 3D documentation

of building components like walls, floors, and ceilings. The PCD segmentation process is implemented through the RANSAC (RANdom Sample Consensus) algorithm, which results in the detection of planes and surfaces related to building components. The geometrical attributes, such as coordinate, width, and length, are then employed to construct the IFC entities for identified elements. The created IFC data model is then used to visualise the 3D geometries.

The use of BIM processes has also gained interest in retrofit and historical buildings. The work presented in Barazzetti, 2016 is an example of using PCD as the primary geometrical data source in the cultural heritage domain. A semi-automated approach is proposed to reconstruct different building components of various historical buildings by utilising NURBs (Non-Uniform Rational B-Splines) functions (Banfi, Chow, Ortiz, Ouimet, & Fai, 2018). A combination of range-based (e.g. Laser Scanning) and image-based (e.g. Photogrammetry) technologies is used to collect the data in the form of PCD. The discontinuity lines of targeted objects are first extracted from the collected data manually by considering NURBs attributes. Following this, control points, as one of the NURBs features, of extracted curves are utilised to form the surfaces semi-automatically. Generated surfaces as geometric constraints are employed to incorporate the external surface of the target element. The external surface is then used to generate solid geometries by extruding identified surfaces based on the required thickness. This approach is applied to different building elements like walls, vaults, and structural components. The fact is that the final results of approaches proposed based on the Scan-to-BIMs method are simple shapes or primitives that only contain geometrical data, such as length, width, area, and volume. However, as mentioned previously, the non-geometrical data needs to be appended to the 3D geometries through a manual process by either converting 3D geometries into building types (building elements/objects) where the non-geometrical data can be attached to the model or creating new building components based on the model specifications.

2.2. Information exchange within the AEC industry

One of the main reasons behind BIM-driven project delivery in the AEC industry is the storage, share, and reuse of information in the form of standard formats (Beetz & Borrmann, 2018; Kumar, 2016), and the objective is to improve the information exchange processes. One of the challenges in the AEC industry is the communication between different BIM platforms which directly impacts the information interoperability performance (Pauwels et al., 2011). Therefore, several open data exchange formats and schemas have been developed to represent the construction data and to enhance the communication between modelling applications and indeed, participants involved in a project. The IFC data model, as well as the Construction Operation Building information exchange (COBie) data format, are well-known and practical examples of data exchange standards within the AEC industry. COBie is an international data exchange standard predominantly used in AM/FM domain for information interoperability and O&M purposes (Shalabi & Turkan, 2016; Volk et al., 2014). However, the existing information exchange standards and formats also show limitations for certain functionalities. For example, COBie is essentially a non-geometrical data source mainly used for sharing the information about an individual building in the form of Excel spreadsheets and cannot be utilised in BIM-driven applications for generating BIM models (Farias et al., 2015; Gui, Wang, Qiu, Gui, & Deconinck, 2019). About the IFC data model, it is not capable of presenting all kinds of non-geometrical data, and commercial BIM applications largely suffer from the limitations of exchanging data and indirectly capturing 3D models of buildings, in particular, existing assets. Hence, some of the information that cannot be presented through the existing information exchange standards and formats is inevitably stored in different file formats, such as PDF, 2D paper-based CAD drawings, Excel spreadsheets etc. outside the model (Sadeghineko & Kumar, 2020).

The use of Semantic Web technologies and standards like web-based ontologies has gained notable interest within the AEC and AM/FM for information exchange, interoperability, and management. To address the challenges and limitations of existing information exchange standards studies have been undertaken to improve existing standards and tools by utilising Semantic Web technologies as a feasible solution. Some of the examples of these are the ontology for IFC, also known as ifcOWL (ifc Web Ontology Language), an ontology for COBie (COBieOWL), and ifcJSON (ifc JavaScript Object Notation). The main idea behind the development of new schemas is to use existing information about a building and convert it into OWL ontologies, which are predominantly used to store and share the information on the Web. While some of the studies focus on using Semantic Web technologies and standards to improve existing data exchange tools, others focus on the development of web-based ontologies to describe construction-related information. The Building Topology Ontology (BOT), Ontology for Managing Geometry (OMG), Building Product Ontology (BPO), and Bridge Topology Ontology (BROT) are examples for such ontologies.

2.3. Web-based ontologies for buildings

In terms of improving existing information exchange standards and tools, studies have been undertaken over the past years proposing web-based schemas by utilising Semantic Web technologies and standards. As mentioned previously, ifcOWL, ifcJSON, and COBieOWL are examples of such schemas. Concerning the ifcOWL schema, the first conversion of IFC schema into OWL was initially proposed by Schevers & Drogemuller, 2005. IFC data model was utilised as a reference example for highlighting and addressing some of the key issues of information exchange and interoperability within AEC. To enhance the applicability and reusability of the IFC data model, Beetz, Van Leeuwen, & De Vries, 2009 proposed a semi-automated approach focusing on the conversion of IFC-EXPRESS into OWL (ifcOWL). Thenceforward, studies have been carried out proposing Web Ontology versions of different IFC formats like OntoSTEP (Ontology for Standard for Exchange of Product data model) version proposed by (Barbau et al., 2012). However, there was a lack of formalisation and standardisation in proposed ontologies. Hence, a more usable and recommendable version of ifcOWL was developed by Pauwels & Terkaj, 2016. The current version of ifcOWL is initially developed by the implementation of IFC-to-RDF (Pauwels et al., 2011) and EXPRESS-to-OWL (Pauwels & Terkaj, 2016) procedures. The main idea behind the creation of ifcOWL was to continue using the IFC standard for the representation of building data and to take advantage of Semantic Web technologies for the distribution, extensibility and reasoning of data (Pauwels & Terkaj, 2016). However, despite the improvement that has been made to the original IFC data model through the use of Semantic Web technologies, ifcOWL also shows limitations in real-world project usage. As stated in (Terkaj & Pauwels, 2017), "*the resulting ifcOWL is a large monolithic ontology that presents serious limitations for real industrial applications in terms of usability and performance (i.e. querying and reasoning)*". In addition to that, in contrast to the original IFC data model, ifcOWL cannot be employed as an information exchange standard for the communication between BIM-driven applications as they do not support such schemas.

Another example of Semantic Web-based schema created for the IFC data model is the work presented in Afsari et al., 2017. The main objective of the proposed method is to provide the JSON (JavaScript Object Notation) representation of the IFC specification. Similar to the ifcOWL, ifcJSON uses the EXPRESS schema to present existing entities of IFC data model schema generated for an individual building project in the form of JSON syntax. The study carried out by Farias et al., 2015 proposes a semi-automated approach for creating the COBieOWL ontology by using the data presented in COBie spreadsheets. The generated COBieOWL is first serialised into RDF Turtle format and then edited in Protégé OWL editor before populating the data. The SPARQL query language is employed in Protégé to manage and manipulate the data presented in COBieOWL ontology. In terms of generating building models using the developed schemas, as mentioned previously, COBie is only used for information delivery of an individual asset in the AEC industry for maintenance purposes in the FM domain, and it cannot be used for generating models within BIM platforms. Moreover, the developed schemas mainly focus on using integrated information exchange standards and Semantic Web technologies to produce shareable data which can be a feasible solution to the information exchange and interoperability limitations within the building industry. However, the data used for implementing such schemas is extracted from an existing model. In fact, the model employed for creating shareable information may or may not incorporate all kinds of data that may be required for different sectors of a BIM process (Sadeghineko & Kumar, 2020).

While some of the studies focus on developing web-based schemas by improving existing information exchange and interoperability tools, some other studies focus on developing Web Ontologies for the representation of structured building data on the Web as Linked Data (LD) or Linked Open Data (LOD). In current practice, the exchange of information and its description come with different data formats, and the communication between them is predominantly through diverse file formats with an implicit relationship between them (Pauwels, McGlenn, Törmä, & Beetz, 2018). However, the concepts of LD/LOD can be a feasible solution to the limitations that hamper appropriate communication between diverse data sources within the AEC industry. The main idea behind the LD/LOD is to use Semantic Web technologies and to combine data distributed in different data formats for enhancing the data interoperability, reasoning, and querying (Lee, Chi, Wang, Wang, & Park, 2016). Moreover, LD is a web-centric approach which provides a mechanism for gathering heterogeneous data formats and presenting them in the form of a homogeneous format. LD uses Semantic Web standards like RDF and OWL as its main structure, i.e. any type and format of data can be combined with LD from other domains as long as they use linked data standards (Curry et al., 2013). Nevertheless, studies have recently been carried out proposing Web ontologies, such as BOT, OMG, BROT, and BPO, for describing building data.

2.4. AEC domain ontologies

The Building Topology Ontology (BOT) as a minimal ontology was initially proposed and developed by W3C LBD CG (World Wide Web Consortium Linked Building Data Community Group). The general idea behind the creation of BOT ontology is to define the relationships between the sub-components of a building in a clear and detailed manner. It also aims to provide the method for the representation and reuse of information within the AEC industry in the form of inter-linked data (Bonduel, Oraskari, Pauwels, Vergauwen, & Klein, 2018). The first version of BOT ontology was initially proposed in Rasmussen, Hviid, & Karlshøj, 2017, and an updated version of this ontology was presented in Rasmussen, Pauwels, et al., 2017 introducing changes applied to the initial version of BOT. Moreover, the definition of terms used in BOT ontology is identified by URIs (Uniform Resource Identifiers) in the BOT namespace (<http://w3id.org/bot#>). The prefix `bot:` is the shortened version of the BOT namespace (`@prefix bot: <http://w3id.org/bot#>`). The current version of BOT encompasses seven classes (e.g., `bot:Zone`, `bot:Site`, `bot:Building`, etc.), fourteen object properties (e.g., `bot:containsZone`, `bot:hasBuilding`, etc.), and one data property (`bot:hasSimple3DModel`). BOT documentation can be accessed through its IRI (Internationalised Resource Identifier) – <http://w3id.org/bot>. In addition, the building product, related properties and geometry ontologies are considered as the sub-groups of BOT ontology which is considered as the central and modular ontology. In other words, BOT ontology can be extended by other domain ontologies (Pauwels et al., 2018).

The Ontology for Managing Geometry (OMG) was initially proposed in 2019 by Wagner, Bonduel, Pauwels, & Uwe, 2019 to describe geometries related to building elements. In other words, OMG ontology focuses on providing the means for linking building objects data to their corresponding geometry descriptions. The OMG ontology documentation can be accessed through its IRI – <http://w3id.org/omg>. The URIs identify the terms in OMG ontology in the OMG namespace (<http://w3id.org/omg#>). Concerning the OMG specifications, an object can be linked to its geometry description through three modelling complexity levels with different levels of functionalities associated with each level. Level 1 provides the means for connecting objects to their geometry descriptions directly. Level 2 of OMG introduces additional functionalities to the model, viz. handling of multiple geometry descriptions of the same objects, adding metadata to the model, and modelling dependencies between geometries. The geometry states as additional functionality, i.e. the version history of the description of geometries, can be included in the model through the use of Level 3 of OMG ontology.

The Building Product Ontology (BPO) (Wagner & Rüppel, 2019) is a minimal ontology designed for describing some of the non-geometrical data, predominantly assembly structures, relationships and connections between product components, properties, and property values, related to their corresponding building products and elements. However, BPO ontology does not support the representation of geometrical descriptions and material compositions of building products. Similar to other ontologies, BPO contains several classes, object properties and datatype properties utilised for representing building product descriptions. More information about BPO documentation can be found through its IRI – <http://www.w3id.org/bpo>. In terms of the topological and geometrical representation of building products, BPO can be extended and combined with BOT, OMG, and indeed other ontologies to enhance the information exchange process about building projects. Several other ontologies are available within the AEC domain, which can be used to represent different building-related data like Smart Energy Aware Systems (SEAS) ontology and Bridge Topology Ontology (BROT). However, BOT, OMG, and BPO ontologies are specifically used to extend the ontology created for the proposed approach, which is described in the following sections.

3. A framework for generating semantically enriched retrofit 3D models using RDF

An appropriate parametric model that is fit for the BIM process of design, construction and O&M of buildings should incorporate geometrical and non-geometrical data. In current practice, the model generated from PCD initially contains only geometric data. The non-geometrical data needs to be appended to generated geometries in order to capture BIM objects that incorporate geometrical and non-geometrical data. BIM applications and related standards and tools like IFC are not capable of representing all kinds of data. Due to these limitations of the data is stored in different data formats, which makes the process of data manipulation, management, and indeed information exchange and interoperability inefficient and difficult. Hence, a framework has been developed in Sadeghineko & Kumar, 2020, which focuses on addressing challenges and limitations involved in generating semantically enriched 3D retrofit models. As shown in Figure 2, the framework consists of three key steps, viz. 1) data collection, 2) data processing and 3) BIM models

generation.

The data collection step focuses on assembling geometric and non-geometric data. The geometrical data such as Cartesian points (coordinates) and geometric properties (e.g., length, width, and height) are extracted from the geometries identified in PCD. In addition, offline and online data sources are used to collect the non-geometrical data. In current practice, the non-geometrical data are stored as offline and/or online data in different formats. These data sources are used to retrieve the required non-geometrical data presented in different data formats. In the data processing step, the collected data is first aggregated into a unified data format. The Resource Description Framework (RDF) as a Semantic Web standard and technology is used as the unified data format to aggregate data collected from distributed data formats. In terms of utilising RDF data to generate BIM models, data presented in RDF is classified into two different sections, viz. IFC and Non-IFC Compliant Data.

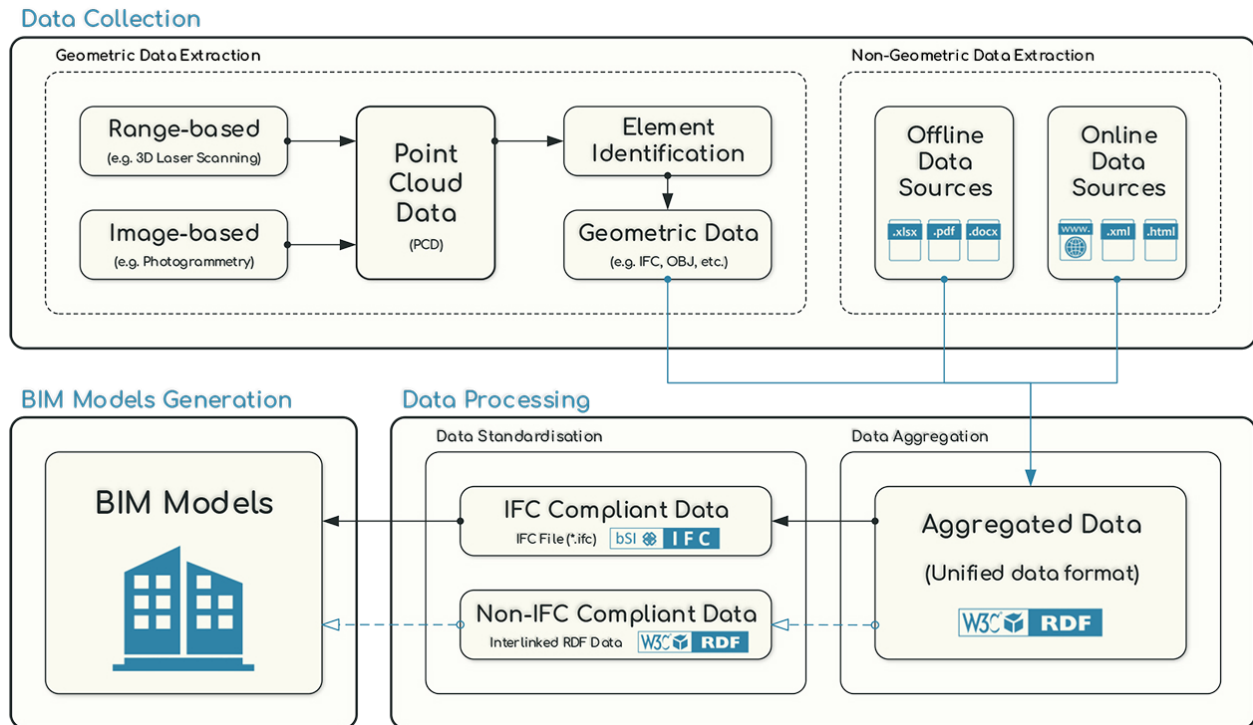


Fig. 2: A framework for generating semantically enriched 3D retrofit models.

As previously mentioned, the IFC data model as the commonly used standard tool for exchanging building information within the construction industry is not capable of handling all kinds of non-geometrical data. Hence, the first section includes data that is compliant with the IFC data model specifications and can be combined with the BIM models through the IFC format directly. The latter section contains data, predominantly a considerable portion of non-geometrical data, that cannot be combined with the model through the IFC. This portion of data remains in the form of RDF data which is interlinked with the model. The structure of an RDF statement is based on three parts, also known as triples, including a subject, predicate, and an object. The subject and predicate are declared as Uniform Resource Identifiers (URIs), and the object can be declared either as a URI or a literal value. URIs provided in the model are used as links to the information associated with BIM objects. Moreover, non-IFC-compliant data can be accessed through these links by importing the IFC file into any BIM platform that supports this format or by opening the model generated from the IFC file in BIM applications such as Revit, BIM 360, and Autodesk A360 platforms. The implementation of an RDF-TO-IFC algorithm carries out the process of generating semantically enriched 3D retrofit models from RDF data.

Furthermore, in terms of scalability and replicability, the developed framework is not limited to a specific building type and can be applied to any type of building, including new, existing and retrofit assets. The geometrical and non-geometrical data of an existing building was used to validate the process of the framework. The building project includes multiple wall components, slabs, door and window openings distributed in two floor plans. RDF data generated for each

individual building element was utilised to implement the RDF-TO-IFC algorithm for creating the IFC file. The IFC file was then employed to generate the model in BIM applications that support this format. Figure 3 illustrates the generated model opened in Autodesk BIM 360 environment as well as the RDF data links associated with their corresponding building objects. These links are utilised as linked data to access the information related to each component. Figure 3 also shows the data related to a wall object presented on the web that is accessed via the live links provided in the model. One of the major advantages of the developed framework is that any type of data, including geometrical and non-geometrical data, can be combined with the model as an interlinked data and the RDF data can also be used as Linked Data (LD) to other data that is structured based on RDF specifications, such as ifcOWL and OWL ontologies. Moreover, the availability of geometrical and non-geometrical data in the form of a standard and unified data format improves the information exchange and interoperability in BIM-enabled projects.

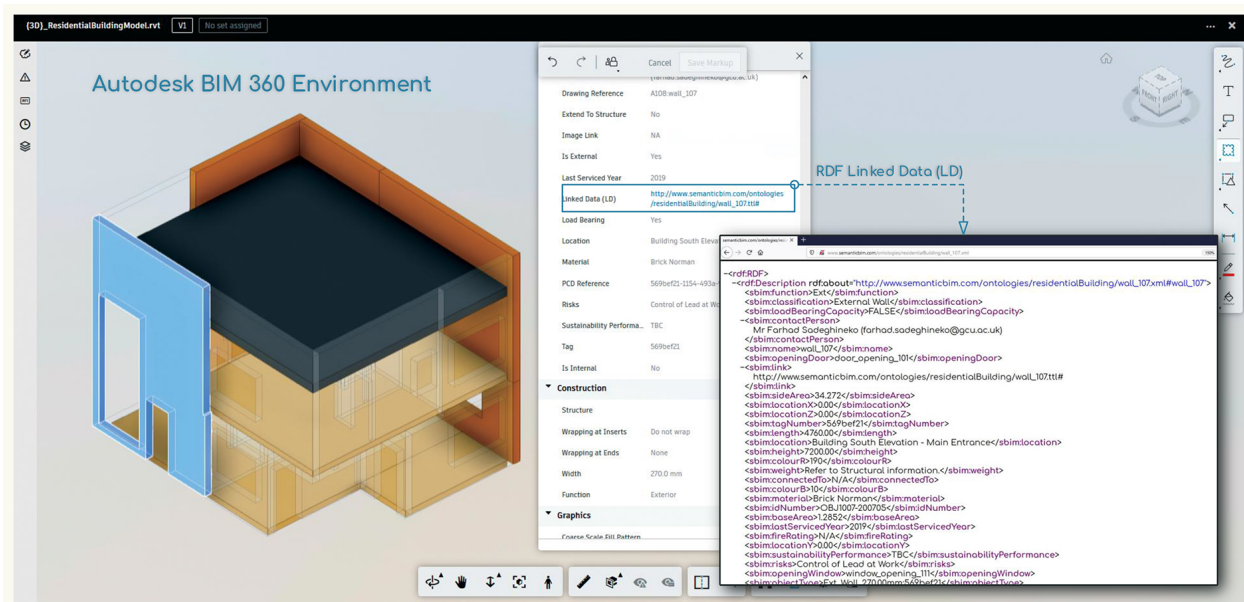


Fig. 3: BIM model opened in Autodesk BIM 360 environment and links that are appended to the model to access data associated with building objects.

4. Facilitating information exchange and interoperability for existing assets

A reliable data format – data unified in a single standard format – which is capable of handling all kinds of data is crucial in the exchange and interoperability of digital building data within the construction industry. In terms of the exchange and interoperability of information, Semantic Web technologies, in particular ontologies, have been used to provide feasible solutions to the challenges and limitations involved in the exchange of construction-related data. The proposal and use of data exchange frameworks that are designed and structured based on the Linked Data (LD) principles can be a promising approach for combining distributed data. An LD-based structure can subsequently provide the opportunity for improving the information exchange processes between stakeholders engaged in construction projects. Concerning the framework described in the previous section, simple RDF data has been used as the single standard and unified data format to aggregate distributed offline and online data, including geometric and non-geometric data. In terms of simplifying the translation process of RDF into IFC, the applicability of RDF specifications has been utilised to create RDF graphs associated to their corresponding building objects, such as site, building, building storey, slabs, internal and external walls, window and door openings. As stated in Sadeghineko & Kumar, 2020, the developed framework was instigated by a partnership between Historic Environment Scotland (HES) and the authors’ institution. With respect to the HES BIM project (Sadeghineko & Kumar, 2020), the provided data has been utilised to structure and generate RDF graphs.

However, this paper proposes an approach which aims to facilitate the information exchange and interoperability for

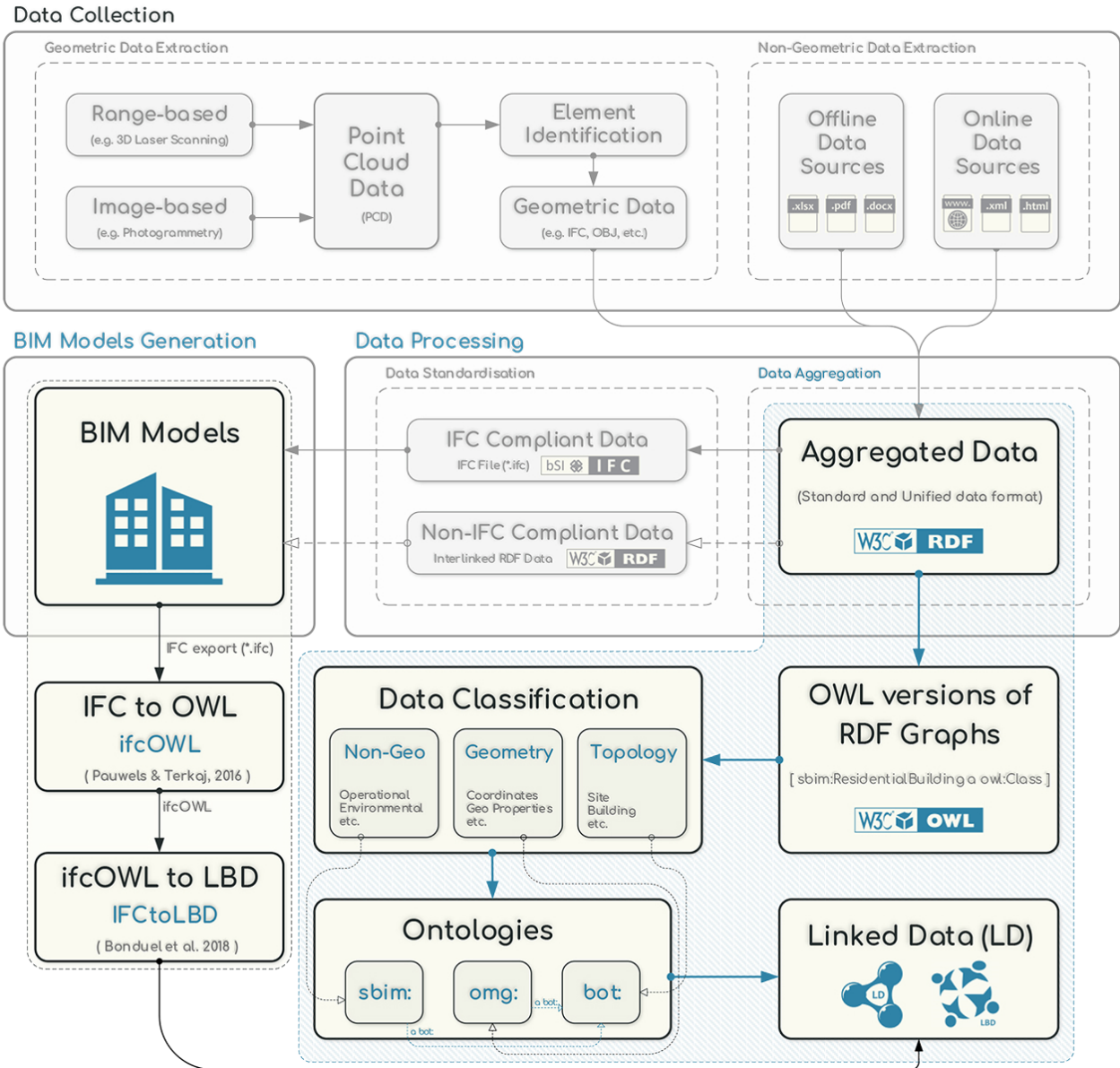


Fig. 4: The Proposed approach for facilitating information exchange and interoperability for existing assets.

existing assets through the use of Semantic Web technologies, including RDF data and minimal ontologies developed within the building environment. The general workflow of the proposed approach is illustrated in Figure 4. First, an OWL version of the data presented in generated RDF data (graphs) is created in order to be able to use data presented in RDF graphs as extended and linked data to other ontologies. Data presented in RDF graphs are classified into three key categories which include Topological, geometrical, and non-geometrical data. The topological category includes data that represent spatial relations about building components. The geometrical data contains geometric properties related to their corresponding building elements. The remaining data, such as operational and environmental data, are presented in the category of non-geometrical data.

The example application used in this paper is about the data of a two-storey residential building which was initially generated through the use of data presented in the form of RDF graphs and the translations of graphs into IFC data model (see Section 3). Different ontologies have been adopted to create the ontology associated with the above-mentioned data. Some of these ontologies have been imported directly into the base ontology in order to use their applicabilities. On the

other hand, there are also other ontologies which are imported into the base ontology indirectly through the import of the first group of ontologies. The namespaces and prefixes of multiple web ontologies that are used in this paper are listed in Table 1. Nevertheless, from a topological perspective, the applicability of BOT ontology can be used to represent the spatial relationships between building elements like zone, site, building, etc. Hence, the proposed framework in this paper uses the BOT ontology to describe the spatial connections and relationships between the elements in the example application. The geometrical data mainly concerns the questions about the shape, size, relative position of objects, and indeed their corresponding properties like length, width, height, etc. The applicability of OMG ontology has been utilised to describe the geometrical representation of building elements.

Table 1: Namespaces and prefixes of the referenced web ontologies and imported ontologies.

Prefixes	Name	Domain
bot	Building Topology Ontology	https://w3id.org/bot#
bpo	Building Product Ontology	https://w3id.org/bpo#
omg	Ontology for Managing Geometry	https://w3id.org/omg#
owl	Web Ontology Language	http://www.w3.org/2002/07/owl#
rdf	Resource Description Framework	http://www.w3.org/1999/02/22-rdf-syntax-ns#
xml	xml	http://www.w3.org/XML/1998/namespace
xsd	xsd	http://www.w3.org/2001/XMLSchema#
foaf	foaf	http://xmlns.com/foaf/0.1/
rdfs	Resource Description Framework Schema	http://www.w3.org/2000/01/rdf-schema#
sbim	sbim	http://www.semanticbim.com/ontologies/residentialBuilding.owl#
seas	Smart Energy Aware Systems Ontology	https://w3id.org/seas/
vann	vann	http://purl.org/vocab/vann/
voaf	voaf	http://purl.org/vocommons/voaf#
terms	terms	http://purl.org/dc/terms/
schema	schema	http://schema.org/
qudt	Quantities, Units, Dimensions and Type Catalog	http://qudt.org/schema/qudt

Moreover, a graphical view of the topological relationships between building elements and their geometrical descriptions is illustrated in Figure 5. The instance (owl:NamedIndividual) sbim:Site_G1 is defined as an instance of the bot:Site class, which is a subclass of the bot:Zone class. The sbim:Site_G1 instance is then linked to sbim:Building_G1 as a bot:Building class instance through the bot:hasBuilding object property. The sbim:Level_1 as a bot:Storey instance is linked to the sbim:Building_G1 instance by the bot:hasStorey object property. The relationships between the building instance and its corresponding elements are defined by the bot:Element class and related object properties. However, the geometrical description of instances is described through the OMG ontology. For example, the sbim:length as an omg:Geometry instance is a geometrical description of the sbim:wall_107 instance which is linked to the sbim:wall_107 instance through the omg:hasGeometry object property.

However, existing ontologies, such as previously described ontologies, are designed based on specific functionalities (e.g. topology, geometry, property management, etc.) and may not be able to support all kinds of data. Hence, depending on the nature of the example application project, new classes, object properties and data properties have been defined in the base ontology to provide fundamentals for describing all data that is represented in RDF graphs. As shown in Figure 6, the sbim:Project class has been created to describe geometrical and non-geometrical information by using previously mentioned ontologies and new entries. For instance, while the coordinate for the project origin point and the spatial dimensions of the BIM model is described by using the OMG ontology specifications, other associated information like the phase of the project (sbim:projectPhase as an instance of sbim:Project is described through the use of new classes, object & data properties (e.g., sbim:hasPhase as an owl:ObjectProperty and sbim:hasLiteralValue as an owl:DatatypeProperty) which are specifically defined for this project.

Other ontologies like Building Product Ontology (BPO) (Wagner et al., 2019) can also be used to extend the ontology created for the example application in order to enhance the applicability of the data exchange process. The BPO ontology is a minimal ontology aiming to describe a schematic representation of building products. In this regard, BPO ontology is used in the proposed approach to describe the building components and their corresponding relationships and connections. As an example of the use of BPO ontology, following the wall and door opening instances illustrated in Figure 5, the inclusion of a door component data through the use of BPO ontology is accordingly shown in Figure 7.

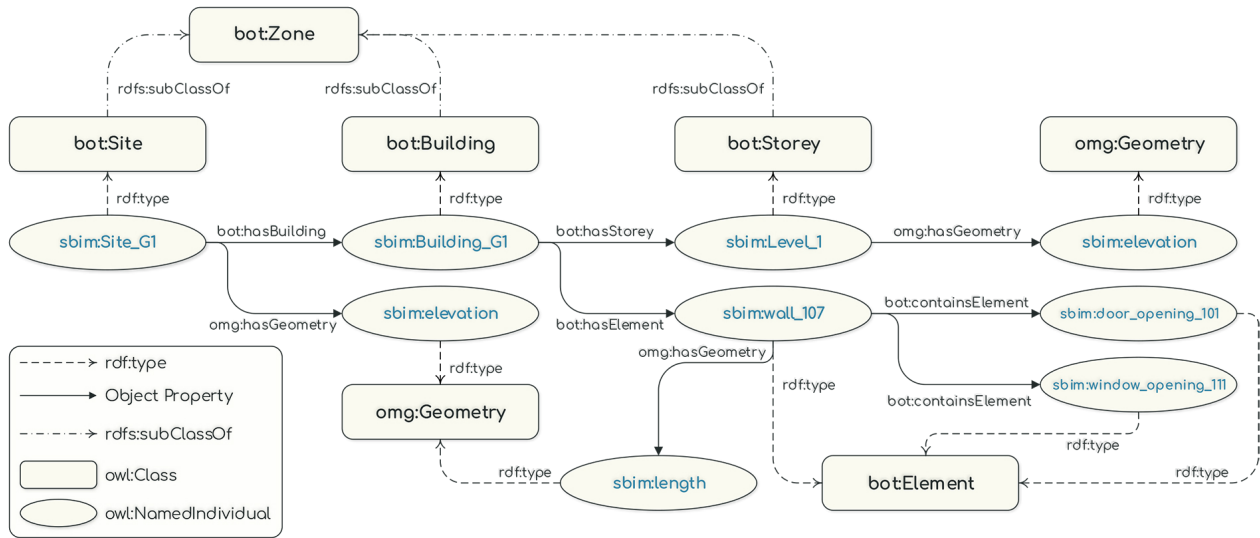


Fig. 5: Topological and geometrical relationships between building elements by using BOT and OMG ontologies.

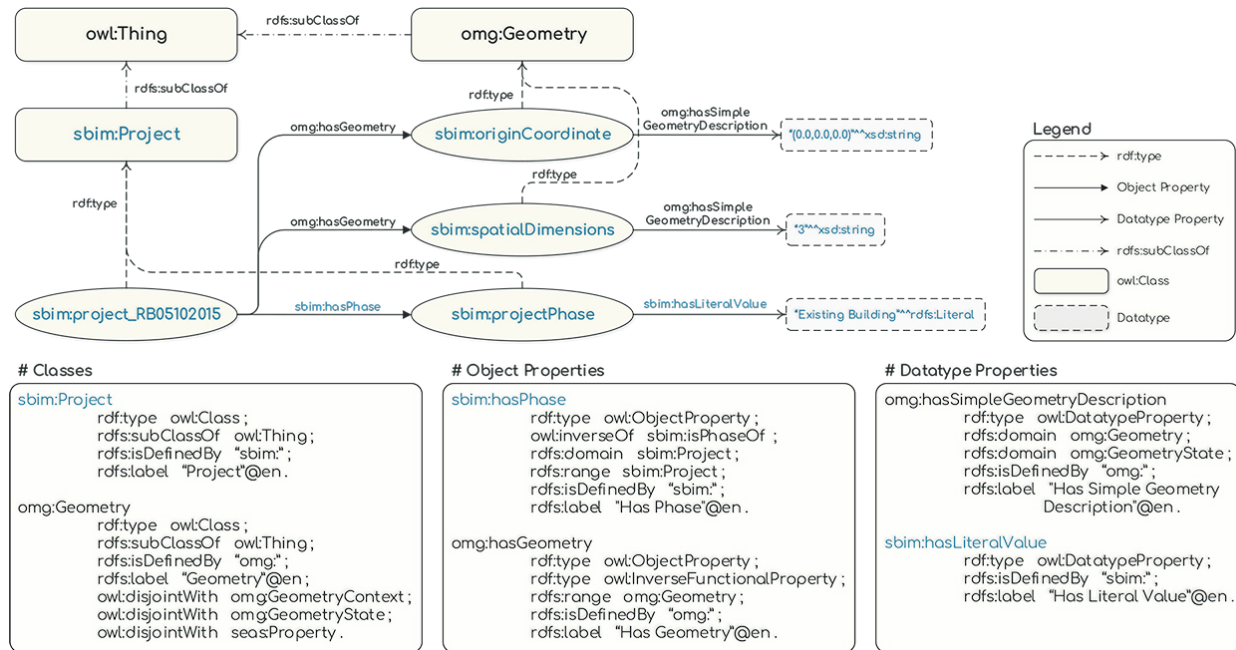


Fig. 6: The relationships between sbim classes and instances and imported ontologies.

Moreover, the material of building elements and components is consequently described through the sbim:NonGeometry class, sbim:Material instance and sbim:hasMaterial object property defined in the base ontology.

The created ontology as the final output of the proposed approach can be used as LD to other domains like Linked Building Data (LBD). As shown in Figure 4, the other capability of the proposed approach is that the information associated with the BIM model can be exported as an IFC data model, and converted into its ifcOWL version through the implementation of IFC-to-RDF (Pauwels et al., 2011) and EXPRESS-to-OWL (Pauwels & Terkaj, 2016) algorithms. The ifcOWL version can subsequently be converted to LBD through the IFC-to-LBD procedure developed by Bonduel et al., 2018. The LBD data can then be used as LD to other domains, including the ontology created for the example application in this paper, for further data exchange purposes.

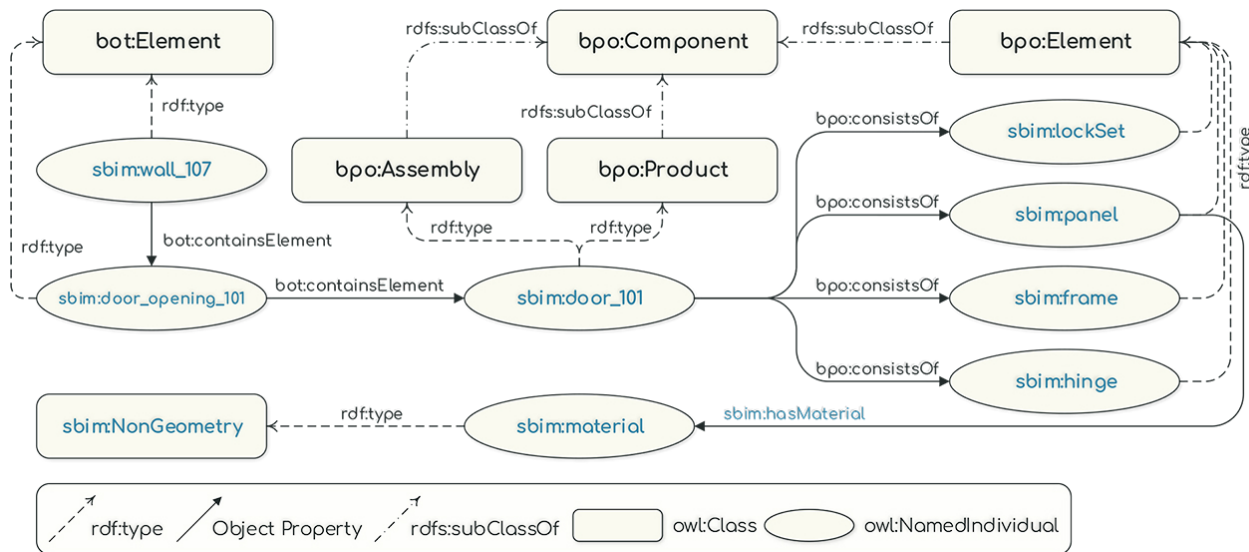


Fig. 7: The description of a door component using BPO ontology.

5. Conclusion

The framework proposed in this paper focuses on facilitating the information exchange and interoperability for existing buildings by using Semantic Web standards and technologies. The framework aims to use previously RDF graphs generated for building elements through the process of aggregating geometric and non-geometric data. As described in Section 3, the data was used to generate BIM models by the translation of RDF into IFC data model. However, the approach presented in this paper focuses on the creation of a web ontology from the data represented in RDF graphs by using the applicability of existing ontologies within the AEC industry. Each of the existing ontologies focuses on particular concepts, e.g. the BOT ontology concerns with the description of topological connections and spatial relationships between building elements without describing geometrical or non-geometrical data. However, one of the advantages of using web ontologies for storing, sharing, and reusing data is that ontologies can easily be extended and linked to other data sources which are structured based on OWL specifications. Moreover, new classes, sub-classes, object and datatype properties can be included in an ontology where required.

The approach presented in this paper is a solution to the challenges and limitations involved in generating semantically enriched 3D retrofit models for existing assets as well as the information exchange and interoperability within the AEC industry. The use of Semantic Web technologies, in particular RDF and OWL, facilitates data management by simplifying the data storage, share, and reuse. It also represents high-quality connected data and provides the basics for publishing linked data. The developed framework contributes to Asset/Facilities Management (AM/FM) and could be beneficial for a variety of AM/FM practices for existing buildings, including a consistent and computable building information/knowledge management for design, construction and O&M of a building's life-cycle, the effectiveness and efficiency of the use of project information during the O&M of facilities, and prompt problem detection and resolution. It can also contribute to other trends related to the information exchange and interoperability like the emergence of the Internet of Things (IoT) in smart buildings, building automation & monitoring, and building-related Information Technology (IT) infrastructure.

References

- Afsari, K., Eastman, C. M., & Castro-Lacouture, D. (2017). Javascript object notation (json) data serialization for ifc schema in web-based bim data exchange. *Automation in Construction*, 77, 24–51. doi: 10.1016/j.autcon.2017.01.011
- Banfi, F., Chow, L., Ortiz, M. R., Ouimet, C., & Fai, S. (2018). Building information modeling for cultural heritage: The

- management of generative process for complex historical buildings. In *Digital cultural heritage* (pp. 119–130). Springer. doi: 10.1007/978-3-319-75826-8_10
- Barazzetti, L. (2016). Parametric as-built model generation of complex shapes from point clouds. *Advanced Engineering Informatics*, 30(3), 298–311. doi: 10.1016/j.aei.2016.03.005
- Barbau, R., Krima, S., Rachuri, S., Narayanan, A., Fiorentini, X., Fofou, S., & Sriram, R. D. (2012). Ontostep: Enriching product model data using ontologies. *Computer-Aided Design*, 44(6), 575–590.
- Beetz, J., & Borrmann, A. (2018). Benefits and limitations of linked data approaches for road modeling and data exchange. In S. I. & D. B. (Eds.), *Advanced computing strategies for engineering* (Vol. 10864, pp. 245–261). Springer. doi: 10.1007/978-3-319-91638-5_13
- Beetz, J., Van Leeuwen, J., & De Vries, B. (2009). Ifcowl: A case of transforming express schemas into ontologies. *Ai Edam*, 23(1), 89–101. doi: 10.1017/S0890060409000122
- Bonduel, M., Oraskari, J., Pauwels, P., Vergauwen, M., & Klein, R. (2018). The ifc to linked building data converter-current status. In *6th linked data in architecture and construction workshop* (Vol. 2159, pp. 34–43). Retrieved from <http://hdl.handle.net/1854/LU-8576838>
- Curry, E., O'Donnell, J., Corry, E., Hasan, S., Keane, M., & O'Riain, S. (2013). Linking building data in the cloud: Integrating cross-domain building data using linked data. *Advanced Engineering Informatics*, 27(2), 206–219. doi: 10.1016/j.aei.2012.10.003
- Dore, C., & Murphy, M. (2015). Historic building information modelling (hbim). In (p. 239-280). *Handbook of Research on Emerging Digital Tools for Architectural Surveying, Modeling, and Representation*, IGI Global. doi: 10.4018/978-1-4666-8379-2.ch007
- Farias, M. T., Roxin, A., & Nicolle, C. (2015). Cobieowl, an owl ontology based on cobie standard. In *On the move to meaningful internet systems: Otm 2015 conferences* (pp. 361–377). Springer International Publishing. doi: 10.1007/978-3-319-26148-5_24
- Gui, N., Wang, C., Qiu, Z., Gui, W., & Deconinck, G. (2019). Ifc-based partial data model retrieval for distributed collaborative design. *Journal of Computing in Civil Engineering*, 33(3), 04019016. doi: 10.1061/(ASCE)CP.1943-5487.0000829
- Hayne, G., Kumar, B., & Hare, B. (2014). The development of a framework for a design for safety bim tool. In *Computing in civil and building engineering (2014)* (pp. 49–56). American Society of Civil Engineers. doi: 10.1061/9780784413616.007
- Klein, L., Li, N., & Becerik-Gerber, B. (2012). Imaged-based verification of as-built documentation of operational buildings. *Automation in Construction*, 21, 161–171. doi: 10.1016/j.autcon.2011.05.023
- Kumar, B. (2016). *A practical guide to adopting bim in construction projects*. Whittles Publishing Limited.
- Lee, D.-Y., Chi, H.-l., Wang, J., Wang, X., & Park, C.-S. (2016). A linked data system framework for sharing construction defect information using ontologies and bim environments. *Automation in Construction*, 68, 102–113. doi: 10.1016/j.autcon.2016.05.003
- Molinero Sánchez, J. G., Gómez-Blanco Pontes, A., & Rivas López, E. J. (2019). Bim methodology in heritage management. In C. L. Marcos (Ed.), *Graphic imprints* (pp. 835–843). Cham: Springer International Publishing. doi: 10.1007/978-3-319-93749-6_67
- Oliver, S., Seyedzadeh, S., Rahimian, F., Dawood, N., & Rodriguez, S. (2020). Cost-effective as-built bim modelling using 3d point- clouds and photogrammetry. *Current Trends in Civil and Structural Engineering - CTCSE*, 4(5). doi: 10.33552/CTCSE.2020.04.000599
- Pauwels, P., McGlinn, K., Törmä, S., & Beetz, J. (2018). Linked data. In A. Borrmann, M. König, C. Koch, & J. Beetz (Eds.), *Building information modeling: Technology foundations and industry practice* (pp. 181–197). Cham: Springer International Publishing. doi: 10.1007/978-3-319-92862-3_10
- Pauwels, P., & Terkaj, W. (2016). Express to owl for construction industry: towards a recommendable and usable ifcowl ontology. *Automation in Construction*, 63, 100–133. doi: 10.1016/j.autcon.2015.12.003
- Pauwels, P., Van Deursen, D., Verstraeten, R., De Roo, J., De Meyer, R., Van de Walle, R., & Van Campenhout, J. (2011). A semantic rule checking environment for building performance checking. *Automation in Construction*, 20(5), 506–518. doi: 10.1016/j.autcon.2010.11.017
- Pour Rahimian, F., Seyedzadeh, S., Oliver, S., Rodriguez, S., & Dawood, N. (2020). On-demand monitoring of construction projects through a game-like hybrid application of bim and machine learning. *Automation in Construction*, 110, 103012. doi: 10.1016/j.autcon.2019.103012
- Rasmussen, M. H., Hviid, C. A., & Karlshøj, J. (2017). Web-based topology queries on a bim model. In *Ldac2017–5th linked data in architecture and construction workshop*. Dijon, France.

- Rasmussen, M. H., Pauwels, P., Lefrançois, M., Schneider, G. F., Hviid, C. A., & Karlshøj, J. (2017, Nov). Recent changes in the building topology ontology. In *Ldac2017 - 5th linked data in architecture and construction workshop*. Dijon, France.
- Sadeghineko, F., & Kumar, B. (2020). Development of semantically rich retrofit 3d models. *Journal of Computing in Civil Engineering*, 34. doi: 10.1061/(ASCE)CP.1943-5487.0000919
- Sadeghineko, F., Kumar, B., & Chan, W. (2018). A semantic web-based approach for generating parametric models using rdf. In I. Smith & B. Domer (Eds.), *Advanced computing strategies for engineering* (Vol. 10868, pp. 361–377). Springer. doi: 10.1007/978-3-319-91638-5_20
- Sadeghineko, F., Kumar, B., & Chan, W. (2019). Employment of semantic web technologies for capturing comprehensive parametric building models. In *Advances in informatics and computing in civil and construction engineering* (pp. 111–122). Springer. doi: 10.1007/978-3-030-00220-6_14
- Schevers, H., & Drogemuller, R. (2005). Converting the industry foundation classes to the web ontology language. In *2005 first international conference on semantics, knowledge and grid* (pp. 73–73).
- Seyedzadeh, S., Rahimian, F. P., Oliver, S., Glesk, I., & Kumar, B. (2020). Data driven model improved by multi-objective optimisation for prediction of building energy loads. *Automation in Construction*, 116, 103188.
- Shalabi, F., & Turkan, Y. (2016). Ifc bim-based facility management approach to optimize data collection for corrective maintenance. *Journal of Performance of Constructed Facilities*, 31(1), 04016081. doi: 10.1061/(ASCE)CF.1943-5509.0000941
- Son, H., & Kim, C. (2016). Automatic segmentation and 3d modeling of pipelines into constituent parts from laser-scan data of the built environment. *Automation in Construction*, 68, 203–211. doi: 10.1016/j.autcon.2016.05.01
- Tang, P., Huber, D., Akinci, B., Lipman, R., & Lytle, A. (2010). Automatic reconstruction of as-built building information models from laser-scanned point clouds: A review of related techniques. *Automation in construction*, 19(7), 829–843. doi: 10.1016/j.autcon.2010.06.007
- Terkaj, W., & Pauwels, P. (2017). A method to generate a modular ifcOWL ontology. In *Proceedings of the joint ontology workshops 2017 episode 3: The tyrolean autumn of ontology* (Vol. 2050, p. 12). Retrieved from <http://hdl.handle.net/1854/LU-8578707>
- Terkaj, W., Schneider, G. F., & Pauwels, P. (2017). Reusing domain ontologies in linked building data: the case of building automation and control. In *Proceedings of the joint ontology workshops 2017 episode 3: The tyrolean autumn of ontology* (Vol. 2050, p. 12).
- Thomson, C., & Boehm, J. (2015). Automatic geometry generation from point clouds for bim. *Remote Sensing*, 7(9), 11753–11775. doi: 10.3390/rs70911753
- Tran, H., Khoshelham, K., Kealy, A., & Díaz-Vilariño, L. (2018). Shape grammar approach to 3d modeling of indoor environments using point clouds. *Journal of Computing in Civil Engineering*, 33(1), 04018055. doi: 10.1061/(ASCE)CP.1943-5487.0000800
- Uggla, G., & Horemuz, M. (2018). Geographic capabilities and limitations of industry foundation classes. *Automation in Construction*, 96, 554–566. doi: 10.1016/j.autcon.2018.10.014
- Volk, R., Stengel, J., & Schultmann, F. (2014). Building information modeling (bim) for existing buildings - literature review and future needs. *Automation in construction*, 38, 109–127. doi: 10.1016/j.autcon.2013.10.023
- Wagner, A., Bonduel, M., Pauwels, P., & Uwe, R. (2019). Relating geometry descriptions to its derivatives on the web. In *2019 european conference on computing in construction* (pp. 304–313). doi: 10.35490/ec3.2019.146
- Wagner, A., & Rüppel, U. (2019). Bpo: The building product ontology for assembled products. In *Proceedings of the 7th linked data in architecture and construction workshop (ldac 2019), lisbon, portugal* (p. 12).
- Wang, C., Cho, Y. K., & Kim, C. (2015). Automatic bim component extraction from point clouds of existing buildings for sustainability applications. *Automation in Construction*, 56, 1–13. doi: 10.1016/j.autcon.2015.04.001
- Zhang, G., Vela, P. A., Karasev, P., & Brilakis, I. (2015). A sparsity-inducing optimization-based algorithm for planar patches extraction from noisy point-cloud data. *Computer-Aided Civil and Infrastructure Engineering*, 30(2), 85–102. doi: 10.1111/mice.12063

CONCEPTUALIZING 3D MODEL DEVELOPMENT AND VALIDATION VIA THE INTEGRATION OF SPEECH COGNITIVE PROCESSING

Andrew Pidgeon, N Dawood

Teesside University, United Kingdom

ABSTRACT: *An element of Building Information Modelling (BIM) involves the production of geometric models as well as their verification and approval which is a labor intensive, time consuming and costly task for individuals, Teams and thus entire Projects respectively. Furthermore, lack of time and skills in 3D production processes add pressure on the design team and can result in quality issues and incomplete specification.*

The research proposal presented in this paper is to utilize already developed speech recognition to machine algorithms alongside connected datasets and integrated workflows with a focus on advancing these verbal actions into 3D geometric outputs via a federation optimization node. Moreover, validation, verification and adaptation of new/existing analysis alongside Rapid Engineering Modelling (REM) and rule engines increases the viability of the given outputs due to the algorithmic nature and confirmation that Standardization has been followed.

In this context the objective of this paper is to introduce and discuss a conceptual methodology that incorporates ML algorithms to assist in the production of 3D models. The methodology incorporates Artificial Intelligence (AI), Neural Networks (NN), dataset integration and cloud processing power.

The main body of the paper discusses the methodology, the algorithms used and identifies the benefit in the context of improving the quality of 3D and reduce led time and cost.

KEYWORDS: *Building Information Modelling, Rapid Engineering Modelling, Data Validation, Model Processing, Speech Recognition, Artificial Intelligence, Design Review.*

1. INTRODUCTION

At the time of writing Building Information Modelling (BIM) has over 1000 definitions and meanings (Barlish et al, 2012). Over recent years there has been a rapid advancement in the number, capability and complexity of technical and non-technical toolsets available to support 3D modelling and data management (Wiley et al., 2015) as well as having the ability to create workflows which allow advanced/customized algorithmic processes in a visual drag and drop fashion.

However, existing methodologies for delivering accurate 3D model outputs are intrinsically linked to inefficiency, manually repetitive and in some cases result in abortive works, with the effort unjustified against the Return on Investment (ROI) or perceived benefits.

Furthermore, there is qualitative and quantifiable evidence as shown in Figure 2 which confirms that the improvements made to modelling software has led to an overall improvement in performance (Caetano et al., 2019), which is measured by the number of functions (or outputs) that the user can produce, their quality and the processing speed at which iterations (2D, 3D, Schedules etc.) can be extracted from the geometrical model.

The paper has been organized in two main section: the first section discusses the typically current high-level processes and delivery methods to produce 3D Models and the second section introduces both the existing advancements of algorithmic approaches and generative design that incorporates an integrated speech-driven 3D modelling process. The methodology presented in this paper should enable non-technical/non-specialists to produce 3D outputs through dataset integration, Artificial Intelligence and optimized processing.

Finally, Figure 1 below shows the typical flow and impacts of the Design process (Archigraphic, 2015), starting with preparation (feasibility studies) through to handover into maintenance. What this shows is that BIM does require an increase in effort at the earlier stages of delivery i.e. concept/developed design, within traditional design processes having a more linear approach leading up to Construction stage. However, this means that for BIM over traditional approaches to Design and Construction at the earlier stage(s) of a Project life cycle, the impact on costs is relatively higher in relation to that of a traditional approach, but the cost of change (should it be required) is lower and thus more manageable. Further, the costs of change for BIM can be reduced if more informed decisions

are made earlier in the programme, which can further reduce overall risk and improve the probability of cost, issues on site and deviations from requirements.

If more accurate and quicker decisions are able to be made at the initial stages of a Project, there is a clear advantage in adopting BIM over traditional design processes. In relation to this paper these are 3D modelling processes and information delivery over 2D outputs and information delivery which would reduce the impact of costs, increase the benefit and promote the better use Digital Toolsets for decision making via BIM.

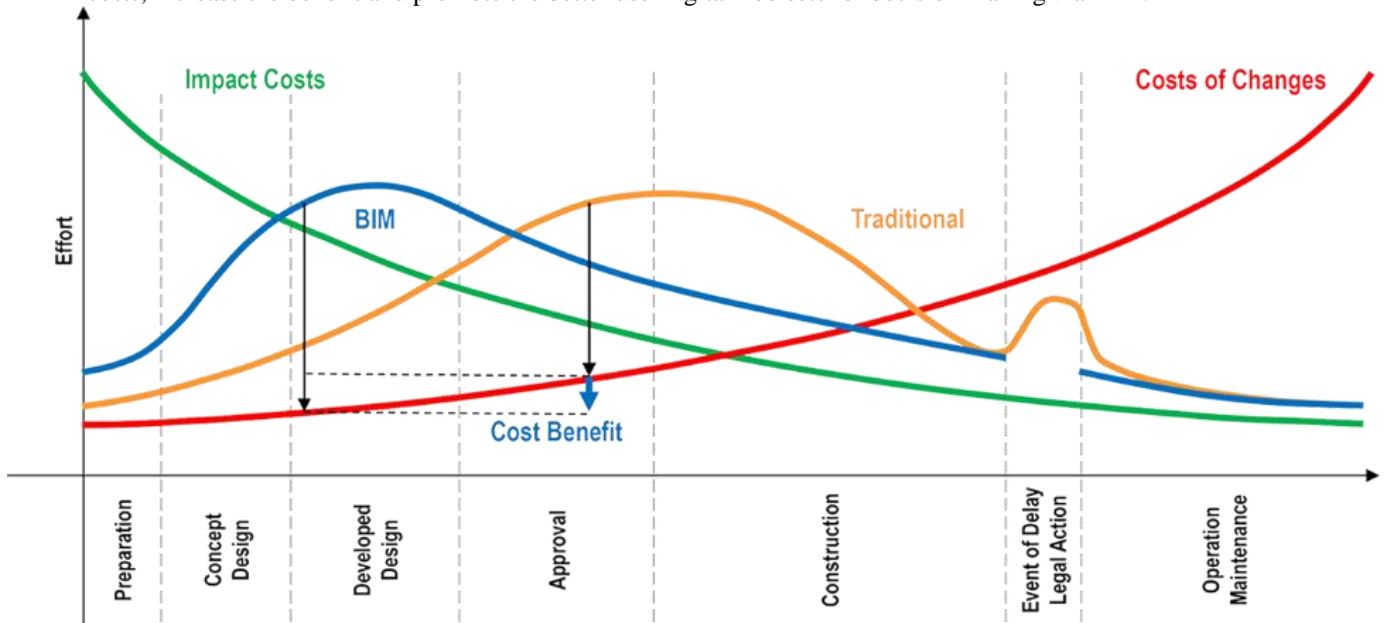


Figure 1: Typical design progress and effort (Source: Archigraphic, 2015)

However, although the toolsets can improve performance of the quality and speed at which outputs can be produced as evidenced by Caetano et al., (2019) in figure 2 below, they still require adequately skilled, trained and experienced resource to master the software and toolsets. Moon et al., (2001) states that this complexity and resource hungry prerequisite takes time and effort and also creates a lag between Project Management requirement and the timely delivery of outputs produced.

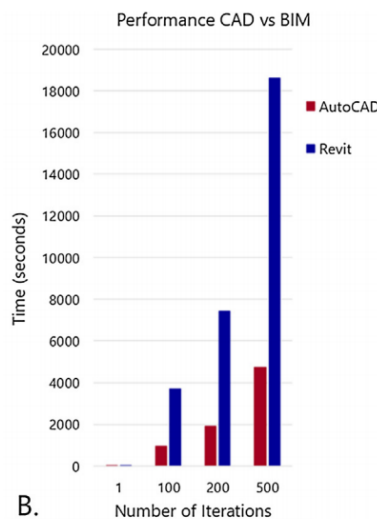


Figure 2: Performance

(Source: Caetano et al., 2019)

improvements of Design Tools

2. OVERVIEW OF CURRENT METHODOLOGY

In 2011 the United Kingdom (UK) Cabinet Office produced a report which outlined an objective to reduce the cost of Government Construction Projects on all Publicly awarded Contracts by 20% (Government Construction Strategy, 2011). Further, within this report it was stated that Government will require ‘fully collaborative Building Information Modelling (BIM) as a minimum by 2016’ through mandated instruction.

The current methodology of BIM is focused towards achieving a collaborative approach to Project Delivery, utilizing a single source of storage where no data resides anywhere else; with governance, assurance and coordination between all Stakeholders for any documentation, 2D/3D/4D/5D/6D (‘nD’) design and analysis deliverables. On top of this there is also the ability to harness and utilize some of the powerful Technology driven tools available which enable highly detailed 3D models with clash avoidance (Akponeware et al. 2017), 4D time analysis and phasing, Common Data Environments (CDE) as well as automating file naming conventions deliverables for improved and consistent information delivery assurance. Figure 3 shows a typical 3D development process which is linear, disconnected and slow.

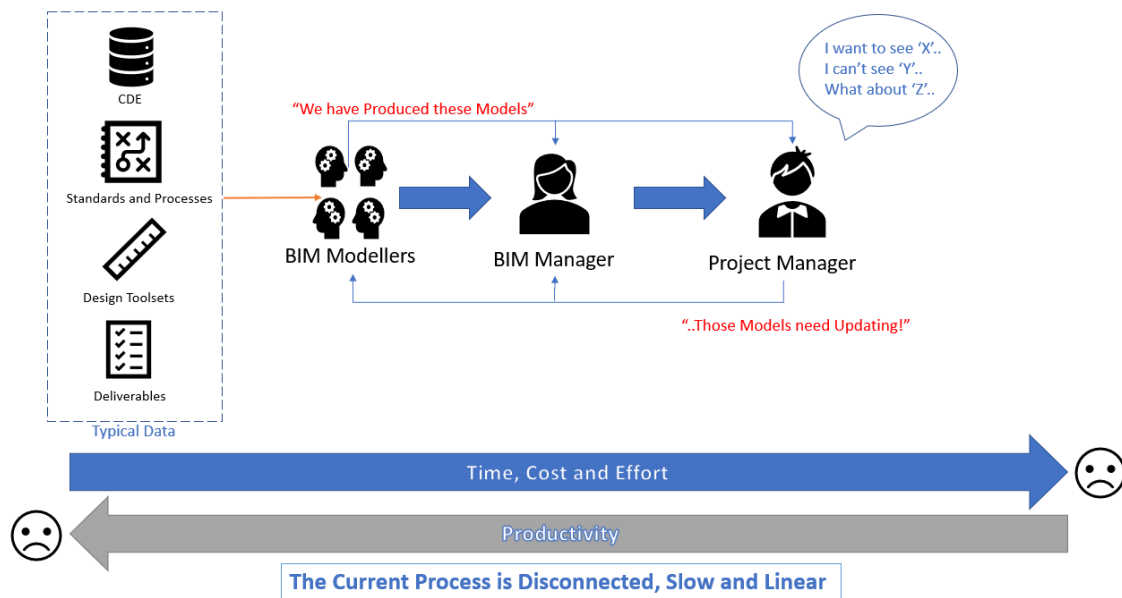


Figure 3: Existing 3D BIM Model Generation Procedure

Current methodologies (see figure 3 above), require a substantial technical expertise and experience to drive the software and takes time, effort and with low productivity. There is also a need for investment in both upskilling staff, hardware requirements and software suitability (Ariyachandra, 2016). However, Barlish et al (2012) states that there is little justification for business leaders to adopt for BIM and its 3D workflows as a delivery mechanism, which is due to lack of success measures being defined (qualitative and quantitative) and also due to a reduced understanding, inefficiency in terms of complexity towards model creation, management, coordination and of course an increase in effort needed. However this being said, there have been defined use cases produced across the Architecture, Engineering and Construction (AEC) industry, defining the benefits against increased and continued growth in terms of adoption of the specific modelling advancements of 3D BIM (Autodesk, 2019), as summarized in Table 1 below:

Table 1: Growth in % of BIM Benefits (Autodesk, 2019)

	2017	2018	2019
Model Coordination	46	61	62
Visualisation	48	50	58
Simulation and Analysis	61	71	74
Scheduling	46	60	75
Collaboration	44	63	58

From a technology driven perspective, there have been developments in areas such as Rapid Engineering Modelling (REM), Parametric and Generative Design for intelligent model production (Buro Happold Engineering, 2016), Grasshopper and Dynamo visual coding integration as well as improvements in cloud processing power which are focused on automating manual tasks, improving productivity and enhancing the speed of model production. In regard to computational approaches to BIM and 3D Modelling production, an existing methodology of “Algorithmic-BIM (A-BIM)” as described by Feist (2016) is a process of using model generation through the integration of algorithms, connecting design packages e.g. Revit, to Python interfaces which then optimizes a geometrical output based on user text input.

What this approach does is alter the focus on delivery from a traditional CAD/BIM user interface and interaction process to one which predominantly requires the user to switch to a procedure-driven workflow. Wojtkiewicz (2014) states that this can result in confusion and complexity due to the new and unrelatable territory in which 3D Modelers now must operate.

However, Feist (2016) has also evidenced that despite A-BIM still requiring manual intervention and a specialist to deliver the alternative approach to model production, it has benefits over the time taken to produce shape, solids and blocks in the authoring software as shown in Table 2 below:

Table 2: Model Production Time Comparisons (Feist, 2016)

	A-BIM	Manual Approach
Floors (Rectangle)	2 min 08s	1h 25min
Floors (Hexagonal)	2 min 52s	1h 37min
Walls	7min 33s	2h 46min
Scaling Adjustments	1 min 20s	1h 52min

In addition to the above, speech to code connectivity has enabled Human to Machine Interfacing (HMI) to become part of everyday living for media, vehicle and smart device interaction, without requiring the human to have specialist knowledge or understanding of how to control a piece of software, hardware or hybrid solution. Ghofrani et al. (2019) states that through the creation of a “layer of abstraction” the inner-workings and complexity of the interface is effectively hidden, yet bringing inclusivity and enabling non-technical users with the ability to interact, engage and execute multifaceted solutions. Further to this, research has been undertaken which claims that the validation of geometric models [3D] via “automated code compliance” (Tan et al., 2010) is not only achievable but a requirement to transition from traditional workflows into the digital production of information. Paredes-Valverde et al., (2015) advance further and promote the link, and thus benefits, between code-based decision making model and natural language requests based on variable requests, commands and the creation of deliverable outputs.

3. SPEECH DRIVEN MODEL DEVELOPMENT

Taking in account the previous sections and the negative elements to the existing procedures focused on 3D Model production which include, but are not limited to, the time it takes to produce models, the labor intensive nature of production, the expertise and specialisms required to drive the software as well a general reduction in the productivity of staff producing 3D outputs as defined above in Table 1, there is an opportunity to create efficiencies via algorithmic-integration through a computational approach to 3D Modelling (Feist, 2016) .

In its current state, BIM 3D Modelling software lacks integration, connectivity between toolsets and require further specialist knowledge to gain benefit from script to geometric design procedures and thus 3D model delivery. However, by integrating some of the individual platforms, workflows, algorithmic functions and integration modules into a single and yet inclusive platform, a speech-driven model development and validation tool could be achievable and realized. Further this may add value by but is also not limited to:

1. Reducing the dependence on Specialist 3D Designers
2. Create improvements on Quality, Productivity and Cost
3. Connect typically siloed technology into a far more powerful integrated design platform
4. Automate the validation and appropriateness of options produced
5. Inclusive approach to Project Delivery

Figure 4 below outlines the principle of connecting and integrating a collection of toolsets, data sources, intelligence and automation for a single and unified approach to 3D Model production and validation driven by voice control/demand.

The Conceptual Methodology; Speech Driven Model Development

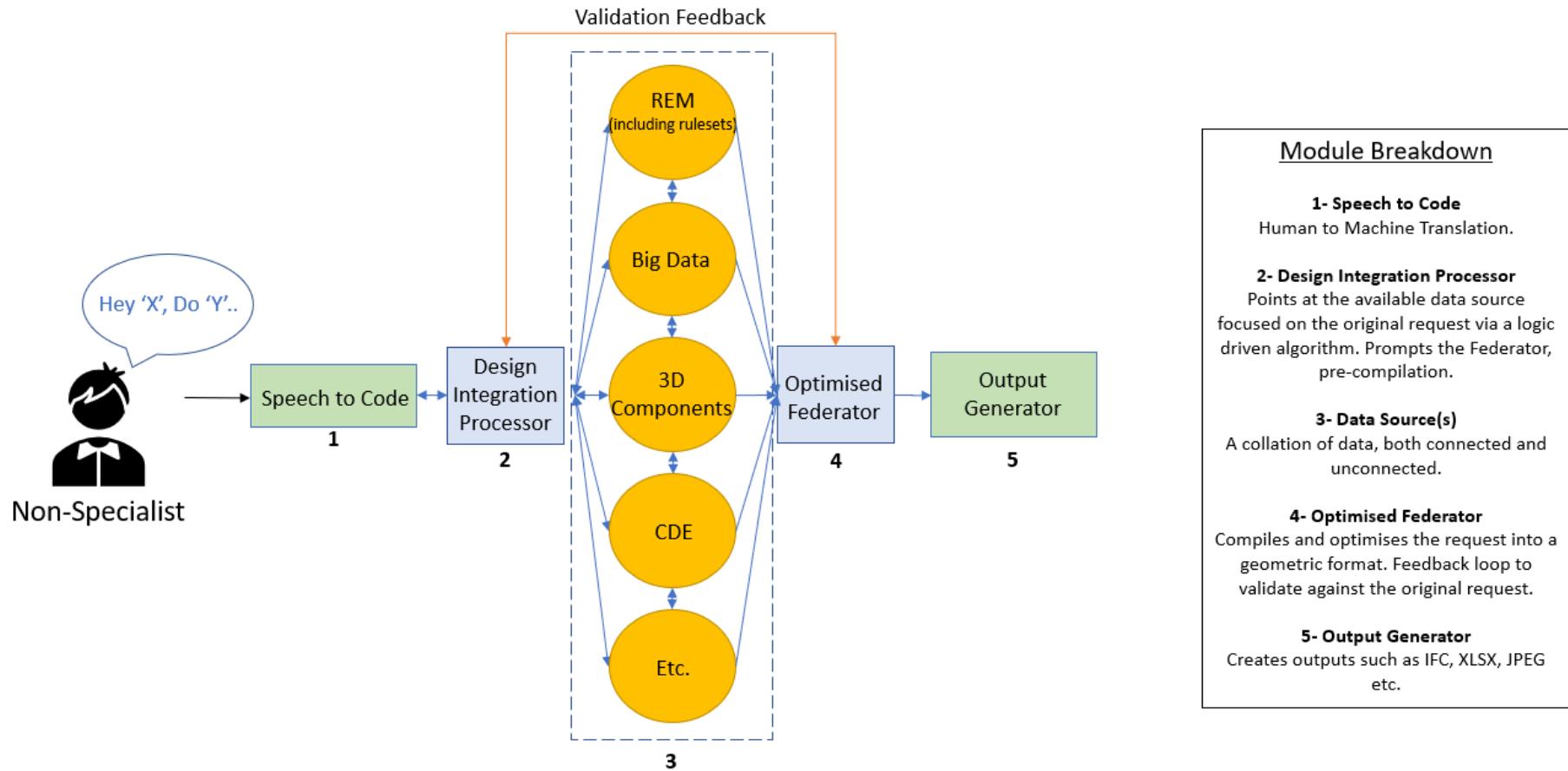


Figure 4: Speech Driven Model Development

4. CONCLUSION

Following the overview of the existing 3D modelling process, procedures and advances whilst then progressing to a concept for a speech-driven integrated and connected methodology, below are the key points summarized:

- Integrates a collation of data sources focused on prompt speech-driven outputs;
- Requires less physical intervention and modelling expertise;
- Improvements made between model development intervals;
- Allows non-technical resource to request and interpret quickly the impact of Conceptual Design proposals;
- Advancements made towards improved Productivity;
- Frees time enabling subject experts to focus on the complex issues;
- Integration of Technologies, drives Industry towards the tangible benefits of Open Protocols;
- Facilitates Generative Design and Digital Twin methodologies;
- Creates a star network of integration, rather than the traditional in-series approach;
- Inclusively enables Stakeholders to quickly create, review and analyze Model viability; and
- Potential to extend into other areas such as speech to model clash resolution of non-connected renditions.

Finally, returning to the previous explanation of the current 3D Model Delivery process, Figure 5 below now outlines the intended focus that the conceptual methodology intends to create efficiencies and thus reduce impacts on cost, decrease the lost effort and improve the early stage Design process with BIM as an enabler.

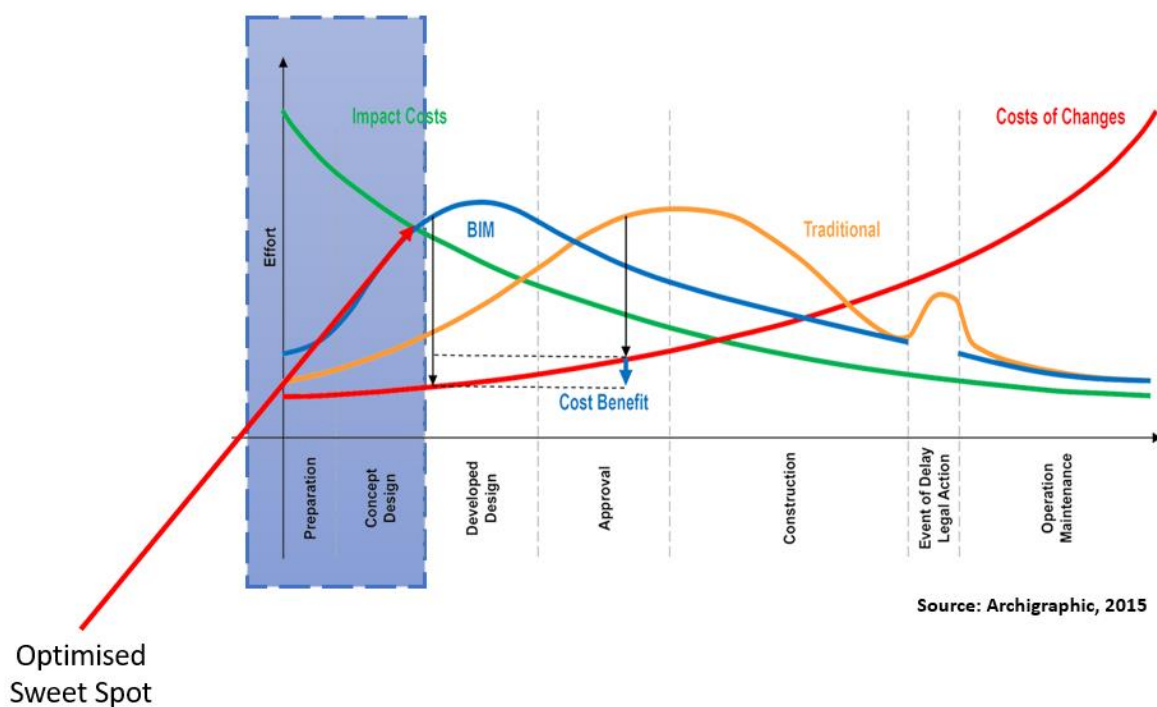


Figure 5: Speech Processed 3D Model Development – Optimization

5. REFERENCES

- Autodesk (2019), Inside look at 12 Projects winning with BIM, [Online] Available at: <https://damassets.autodesk.net/content/dam/autodesk/www/solutions/bim/q3-adsk-bim-excellence-ebook-v0.12.pdf> [Accessed in September 2020].
- Akponeware, A. and Zulfikar, A. (2017), Clash Detection or Clash Avoidance? An Investigation into Coordination Problems in 3D BIM, School of Civil and Building Engineering, Loughborough University.
- Archigraphic, (2015), BIM v's HOAI...?, [Online] Available at: <http://wordpress.archigraphic.de/en/2015/04/20/bim-vs-hoai/> [Accessed in September 2020].
- Ariyachandra, M. (2016), Strategies to develop effective BIM models to suit 4D modelling, University of Cambridge.
- Barlish, K. and Sullivan, K., (2012), How to Measure the Benefits of BIM - A case study approach. Automation in Construction, 24(1), 149-159.
- Buro Happold Engineering, (2016) Louvre Abu Dhabi – Structural Excellence, [Online] Available at: <http://www.burohappold.com/technical/louvre-abu-dhabi-structural-excellence/> [Accessed in September 2020].
- Cabinet Office, (2011), Government Construction Strategy, [Online] https://assets.publishing.service.gov.uk/government/uploads/system/uploads/attachment_data/file/61152/Government-Construction-Strategy_0.pdf [Accessed in September 2020].
- Caetano, I. (2015) DrAFT: An algorithmic Framework for Façade Design, M.Sc, Instituto Superior Técnico.
- Feist, S (2016). A-BIM: Algorithmic-based Building Information Modelling, Tecnico Lisboa.
- Ghofrani, J. and Reichelt, D. (2019), Using Voice Assistants as HMI for Robots in Smart Production Systems, HWT Dresden.
- Moon, H., Choi, M., Kim, S. and Ryu, S., (2011), Case Studies for the Evaluation of Interoperability Between a BIM Based Architectural Model and Building Performance Analysis Programs, International Building Performance Simulation Association, Sydney, Australia.
- Paredes-Valverde, M.A., Valencia-Garcia, M. A, Colomo-Palacio, R, Alor-Hernandez, G (2015), A semantic-based approach for querying linked data using Natural Language, Journal of information Science, Volume 42, issue 6, 2015, p 851-862.
- Tan, X., Hammad, A. & Fazio, P., 2010. Automated code compliance checking for building envelope design. Journal of Computing in Civil Engineering, Volume 24, pp. 203--211.
- J.O. Wiley and S. O. Sons “BIM And Construction Management, Proven Tools, Methods, And Workflows” Published Simultaneously in Canada, 2015, pp 2-359.
- Wojtkiewicz, S. (2014), Generative Systems in architecture design, Generative Design Lab, pp. 334-346.

IMAGE-BASED VERIFICATION AND MAPPING OF PHYSICAL BARRIER FOR WHEELCHAIRS

Rio Takahashi, Hiroshige Dan, and Yoshihiro Yasumuro
Kansai University, Japan

ABSTRACT: *In recent years, Japan is facing an urgent necessity to cope with the rapidly aging society. So as the number of wheelchair users increases and the government is promoting barrier-free. However, available barrier information around wheelchair users' life is not sufficiently detailed, and the managers of a large-scale facility also have difficulties in understanding the actual barrier conditions. Therefore, this research proposes a barrier verification system that is easy to use and easy to understand for facility managers to maintain and manage barrier-free facilities. As a depth camera acquires a 3D point cloud of the target space, interference with volume could be occupied by the wheelchair is found as barriers. The detected barriers are highlighted and integrated with a wide-angle color camera frame to produce an augmented reality representation for easy understanding for generic users. Besides, collected barrier information can be efficiently reused by 3D mapping and accumulated through an image-based 3D reconstruction technique. This paper reports the implementation method and the barrier verification result obtained by the experiment. The experimental result shows that the proposed system provides the compatibility of real-time barrier verification and efficient information recording.*

KEYWORDS: *Wheelchair, Barrier-free, Depth Camera, Point Cloud, Augmented Reality*

1. INTRODUCTION

In Japan, where aging is accelerating in recent years, the proportion of people aged 65 and over in the national population is about 35.88 million as of 2019, and the aging rate is 28.4% (Cabinet Office, Government of Japan, 2018). Globally, the aging rate is expected to rise rapidly from 8.3% in 2015 to 17.8% in 2060, and aging is progressing rapidly. Among them, Japan has the highest aging rate. In addition, the outing rate of the elderly is around 60% (Ministry of Land, Infrastructure, Transport and Tourism, Japan, 2017), and for the elderly to go out without hesitation, it is necessary to develop an environment where they can coexist with non-disabled people of other generations and move independently. In the use of wheelchairs, which are often used by healthy older adults, small steps and narrow spaces that are not noticed by non-disabled people can be obstacles to daily life as physical barriers. Although a new barrier-free law was enacted in 2006 and barrier-free maps have become widespread, it is not easy to make barrier-free maps in existing facilities. It is even more challenging to obtain barrier information that covers the daily-life walking traffic lines.

Currently, there are four steps in the implementation procedure for considering a specific welfare environment development (M. Sato, 2011). First, fill out a check sheet to understand the living activities of people with disabilities, then measure the desired repair points using graph paper, scale, etc., and then create a sketch from the measured data, and finally overlook it. Take a picture of the current situation so that it does not exist. It can be said that this procedure is one of the difficulties in advancing barrier-free, because it requires a lot of expertise and time to find out the area to be measured.

Besides, in many local governments, the maintenance system of public facilities is maintained and managed by each department independently in charge of the facility. 52.6% of the total is a facility group that cannot understand the current situation and sorts out problems in facility management (Japan Business Association Development Center-Management Research Institute). This situation implies that facility managers generally do not understand the actual conditions for promoting a barrier-free facility environment. The items checked by the experts mentioned above also include information that can be read from the facility design drawings. However, there are many cases where things that cannot be detected by temporary observation, such as the installation of retrofit equipment and daily necessities, carry-in objects, and bicycle parking, become daily barriers.

Therefore, in this research, we propose a system that easily verifies and confirms physical barriers for wheelchair users. By making it possible to easily verify familiar barriers that are difficult to notice, facility managers can easily grasp and improve the current situation and create a comfortable environment for both wheelchair users and healthy people, which will increase in the future. The purpose is to be useful.

This research proposes a system that quickly verifies and confirms physical barriers for wheelchair users. By making it easy to verify common barriers that are difficult to notice, facility managers can easily understand and improve the current situation. Since this system design is intended for facility managers, it is not designed to be attached to a wheelchair. This study aims to promote barrier-free maintenance by the facility manager incorporating this system as part of the regular inspection work of the facility and creating a comfortable environment for both wheelchair users and healthy people.

2. RELATED WORK

The authors' group obtained distance images in real space with a depth camera instead of bringing out a real wheelchair and calculated the interference parts between the 3D data of the target space and the 3D volume occupied by the wheelchair. This interference locates the physical barriers (R. Takahashi, et al., 2018). Instead of creating a detailed 3D model suitable for barrier verification in the real environment, the 3D point cloud in the real space acquired by the depth camera is directly used to detect the interference between the space occupied by the wheelchair and the surrounding objects. By doing so, accuracy and real-time processing are possible.

In particular, a cylindrical wheelchair model with the outer dimensions of the wheelchair is virtually settled, the floor plane estimated from the 3D point cloud obtained from the depth image. Checking the intersection between the space occupied by the wheelchair model and the surrounding environment of the 3D point cloud can be quickly confirmed.

The advantage of this method is that the barrier's geometry can also be acquired quickly and the existence of the barriers by processing information of the environment as point cloud data. Besides, robust detection of the floor surface has also confirmed the ability to detect steps and slopes that act as barriers. It has been confirmed that the barrier due to the floor inclination can be detected from the relationship between the vertical direction and the normal direction of the floor surface obtained by plane estimation. The vertical direction can be detected by an acceleration sensor mounted on the mobile terminal. (R. Takahashi, et al., 2018) However, while it is easy to use on the spot only by shooting with a depth camera, both of the field of view and the resolution of the depth camera are limited, and thus, it was not easy to identify where the barrier verification is going on for the user. In other words, barrier verification can be performed quickly, but the presentation method has not been studied, and there remains a problem in terms of ease of use for the user.

3. METHOD

3.1 Process Chain

In this research, in order to provide the user with a barrier detection function in a visually easy-to-understand manner and to freely check and utilize the verification results, the detected barrier is emphasized in a wide-angle field of view and a color image, and this AR image We propose a barrier map that superimposes on a three-dimensional model that matches the real environment.

The processing procedure of the system is, as shown in Figure 1. In this figure, the squares represent the processing content, and the rounded squares represent the data. The hatched area in the figure is the depth camera's barrier detection process (R. Lange, P. Seitz, 2001). In the 3D point cloud acquired by the depth camera, a cylindrical model of the wheelchair is installed on the floor estimated by the plane approximation using RANSAC (Random sample consensus), and the point cloud that interferes with the model is detected as a barrier. The dotted line part in Fig. 1 indicates a projection matrix that projects the 3D subject of the depth camera onto the image plane of the color camera. This projection matrix is obtained by giving the correspondences between the 3D coordinates captured by the depth and the 2D pixels on the color camera image. Eventually, the AR display of the barrier is generated by accurately projecting the three-dimensional barrier detection results in real time from the perspective of the color camera. Furthermore, as post-processing, in the lower right part of Figure 1 in the broken line part, 3D data of the target space is created from the color image set used for verification, through 3D reconstruction techniques, such as SfM (Structure from Motion). The AR verification results of the barrier verification are also integrated into the reconstructed 3D space. This paper superimposes the barrier verification results at the verified camera viewpoint positions to make a 3D barrier map that reflects the barrier distribution in the real environment.

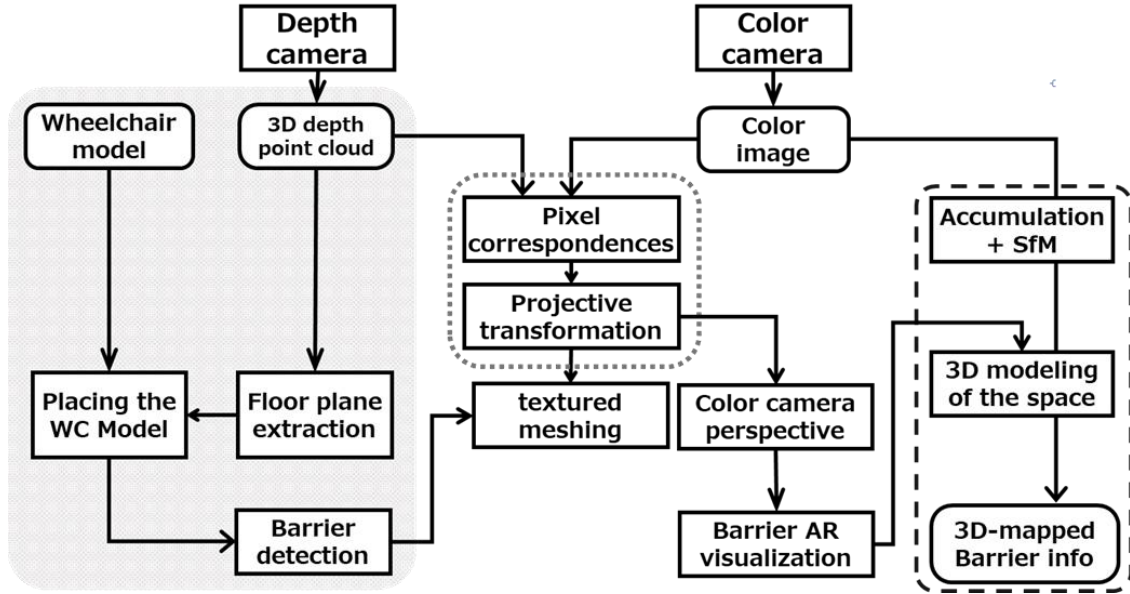


Fig. 1: Process chain

3.2 Color Barrier Verification

Fig. 2 shows the procedure for projecting the barrier information detected on the depth image onto the color image and performing the Barrier AR display. In order to display the positions of the barrier and wheelchair on a color image in AR, the color camera and the depth camera are associated with 2D and 3D, and the 3D point cloud is polygonised, and texture rendering is performed from the viewpoint of the color camera.

First, the internal parameters are obtained by calibration of the color camera, and the PnP (Perspective-n-Points) problem is solved based on the combination of the three-dimensional points observed by the depth camera and the pixels on the color camera image. Determine the projection matrix that transforms the depth camera viewpoint to the color camera viewpoint. Furthermore, by projecting a 3D point cloud onto a wide-angle color image, one-to-one pixel correspondence can always be achieved, and the 3D point cloud can be displayed from the perspective of a color camera.

Next, the 3D points for which the barrier judgment was made in the barrier verification work are marked. A color camera image is displayed as the background, a polygon with point clouds as vertices are formed on the front surface, and the barrier is highlighted in red to represent an AR in which the barrier information is superimposed on the live-action image. Moreover, polygon mesh is constructed by connecting all points, and a three-dimensional CG is drawn by mapping a color image as textures. This rendering process makes it possible to display occlusion such that the virtual wheelchair model under barrier verification is hidden by an object that exists, and the spatial arrangement of barrier verification can be easily seen.

3.3 Overlay mapping of barrier verification to 3D model

Although the barrier verification result can be displayed in AR in realtime as described in the previous section, a function is needed so that the verification result and its process can be quickly confirmed at any time. In this paper, the progress of verification work is mapped in a verification space that is a three-dimensional model, and the verification results are superimposed and displayed as a three-dimensional CG on a Web browser. First, a textured mesh model is created by using SfM (Structure from Motion) technology to restore the 3D shape of the real environment from multiple color images taken during verification. This process saves the cost of creating a 3D model separately. SfM estimates the 3D shape and the position and orientation of the camera from multi-view images.

Next, by projecting the barrier verification result image at the estimated position and direction of the camera on

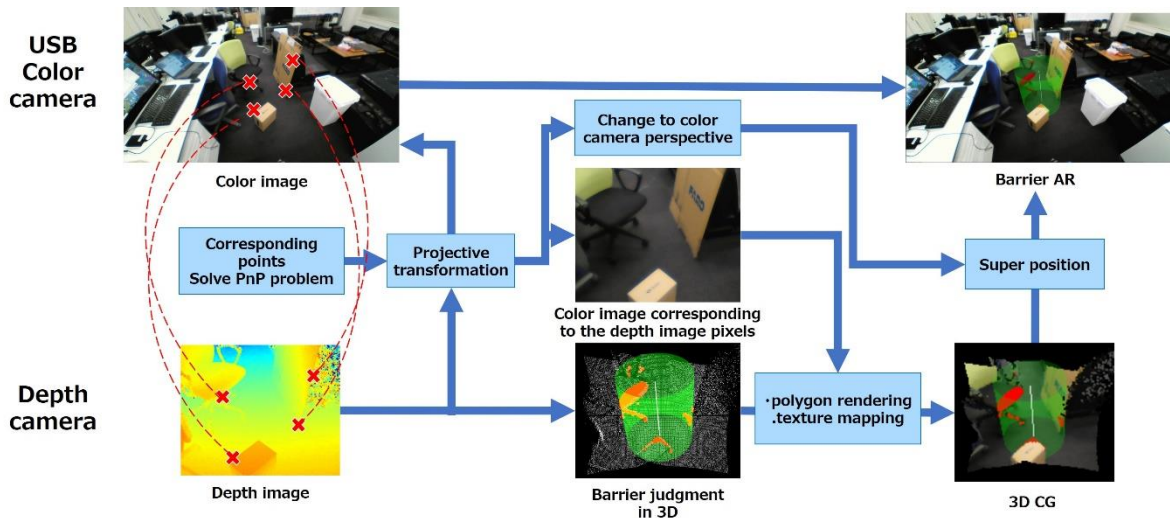


Fig. 2: Process flow for creating Color AR

IMPLE the 3D model displayed on the Web, the viewpoint and the target part in the verification work are reproduced. The verification results can be listed. It becomes a dimensional model. By implementing with WebGL, it can be displayed as an interactive 3D CG on a Web browser. Also, the resulting image is placed as an icon at each viewpoint, and a function to pop up a detailed AR result image by adding it to the screen is added.

In this way, the user can get a bird's-eye view of the past verification environment and the actual state of the barrier, and we think that it can be useful for the continuous maintenance of a barrier-free environment.

4. IMPLEMENTATION

4.1 System Development

In this study, we conducted an experiment on indoor living space, considering the barrier verification in the flow line in the daily life of wheelchair users. Near-infrared TOF (Time of Flight) 3D distance measuring camera SwissRanger SR4000 (Mesa) was used to obtain 176×144 pixels depth images up to 5m distance. UCAM-C750FBBK (manufactured by ELECOM) was used as a color camera, and a color image of 1024×768 pixels was acquired. We used Visual Studio 2015 (Microsoft) for the development environment, OpenCV for image processing, and OpenGL for AR display.

As shown in Figure 3, the user is supposed to use the proposed system by facing the floor of the place to be verified and holding a set of devices with a USB camera fixed to a depth camera connected to a PC. In this experiment, assuming the living environment in which many commodity and office supplies were placed on the floor, we verified the curved passage. The system recorded the sequence of the verification process in which the user virtually moved the wheelchair mode and verified the barriers. The wheelchair model is a cylinder based on the standard of the Ministry of Land, Infrastructure, Transport and Tourism, and JIS (Japanese Industrial Standard), as shown in Fig. 4, with a height of 100 cm and a turning radius of 35 cm.

The transmittance of the model color is set so that the red part of the barrier can be detected in any direction. Besides, these numerical values can be changed immediately even during the verification, and by supporting the model drawing on / off, the number of barrier confirmation methods has been increased to assist the user in the verification method. This system is compatible with the size of the wheelchair user's physique, the type of wheelchair, and the range occupied by the movement.

As shown in Fig. 5, the verification was conducted along the passage with many objects placed on the floor. While the user walks along the passage with the system in hand, the verification results are dynamically displayed in realtime (30 fps or more). We will pick up at five representative places in this passage.

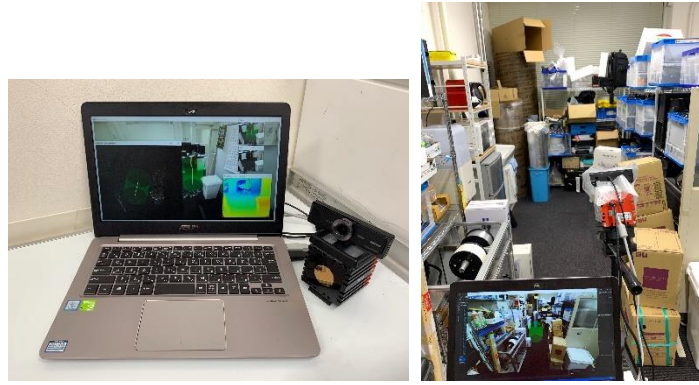


Fig. 3: Device used for implementation

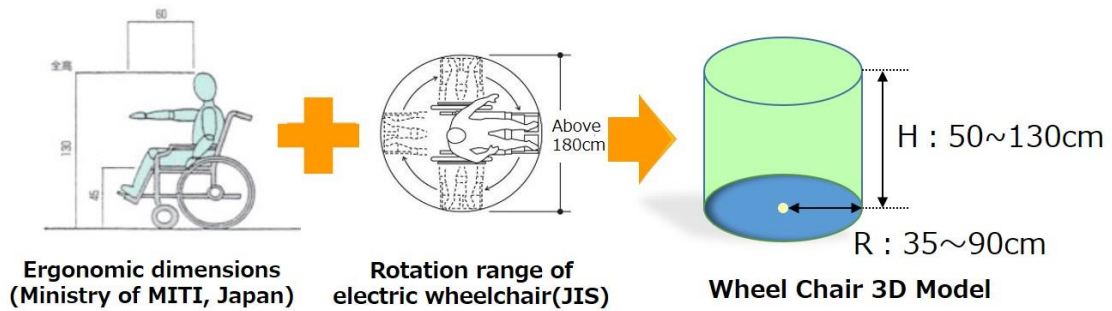


Fig. 4: 3D wheelchair volume model, considering an ergonomic dimensions and industrial standards

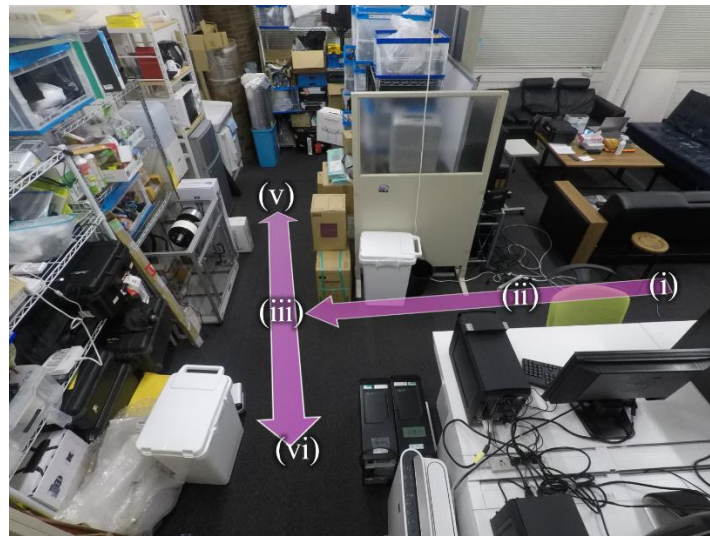


Fig. 5: Barrier verification area

4.2 Case Study in a Passage in the Laboratory

In the verification, as shown in Figure 6, the point cloud that entered the wheelchair model represented by a green cylinder centered on the white normal is detected as a barrier. The point cloud detected as a barrier is displayed as a three-dimensional CG with a polygon emphasized in red, superimposed on a color image. The wheelchair model has the diameter (70 cm) of the actual wheelchair in (1), (2), (4), and (5) in the verification part that goes straight in the aisle (Fig. 6), and the rotating motion diameter (100 cm) in the case of bending at a right angle (3).

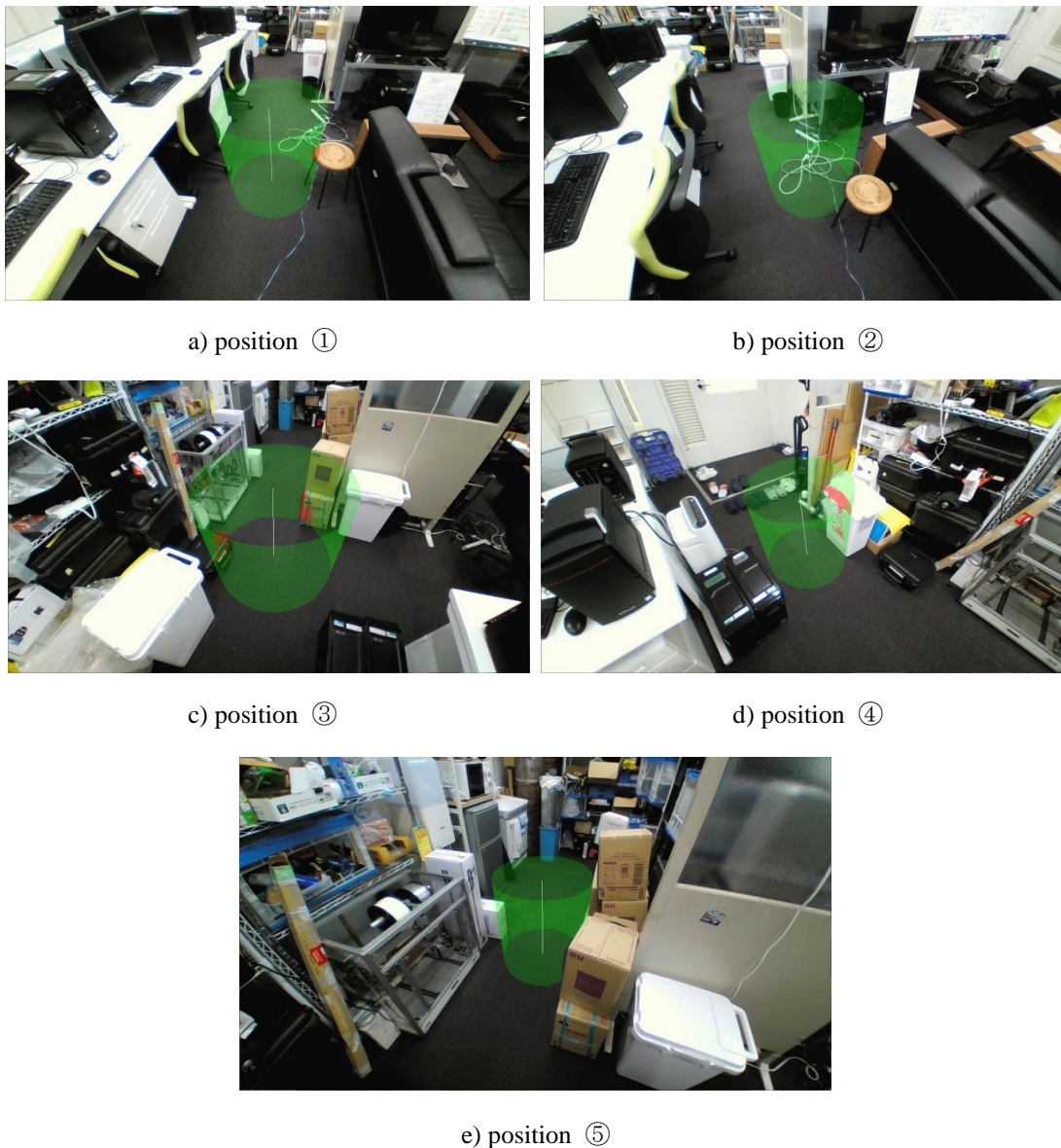


Fig. 6: Examples of the results

At verification position, (1) and (4), a box and a round chair are detected as barriers and highlighted in red. At verification points (2), the wheelchair model goes through on a bundle of wiring cords, but the wiring cords are not judged as barriers because they 2 cm or less from the floor surface. Position (3) is a corner, an area where a wheelchair takes the most space to rotate to change direction, but cardboard piled up at the corner, and articles placed on the floor become barriers. At position (5), the passage is narrower than it should be due to the corrugated cardboard wall placed randomly and the equipment, but it can be seen that there is no problem in going straight. Further, the model is partially occluded according to the shape of the cardboard placed in front of the wheelchair model, and it is possible to instantly grasp the front-rear relationship between the real object and the model.

During this verification work, 56 images taken with a color camera were recorded. Using these input color images, SfM processing was performed by Metashape (manufactured by Agisoft) to create a 3D model (Fig. 7). Figure 8 shows the layout of the verification result images based on the information of the shooting viewpoint and direction for the color images used for verification at the 5 locations (1) to (5) in Fig. 5 obtained as a result of SfM. When the model of the verification space in Fig. 5 is captured from above, the verification result images at three locations (Fig. 6) are superimposed with three quadrangular pyramids from the actual camera viewpoint. If you click this square pyramid, you can confirm it by popping up the image in another window (Fig. 9). Since the above functions

can be used with a Web browser, it is possible to view the location of the barrier, regardless of location and time, while changing the angle, and to clearly understand the aggregation and distribution of barrier data. it can. At the corners where wheelchair users must pay particular attention to the multi-directions of the passage when passing, we were able to confirm the three-dimensional barrier object and its range from various angles at once. In addition, from the result of having a wide-angle field of view, it is clear which part of the whole room corresponds to the place currently being verified, and it can be said that the fusion of the wide-angle color image and the depth image is highly effective. Also, the objects that were determined as barriers as a whole were more dynamic objects that were temporarily placed than the permanently installed equipment, and it was found that the barriers may frequently appear due to the attention of healthy people, We believe that daily verification with this system will lead to facility management that is barrier-free. In addition, since the 3D barrier map generated after verification can be used to check the space and barrier in detail on the Web even in a place away from the verification place, it is possible to use the 3D barrier map to record future changes in the shape of the space. It can be expected to be utilized for various renovations.

In this research, by using a barrier verification system that combines a depth camera and a wide-angle color camera, walking with the camera as if pushing a wheelchair dynamically visualizes the presence/absence of a barrier in real time from any route/shooting viewpoint/direction. While making the most of the convenience of being able to do so, we have proposed a method for easily recording the information of barrier verification obtained in three dimensions, which has high readability, and showed its effect. According to the previous research, since the information between the cameras is accurately integrated in the barrier verification by the depth camera with a relatively narrow angle of view and the AR display of the result by the wide angle color camera, It was confirmed that it is possible to integrate the work record and the verification result in the same space by three-dimensionally reconstructing the target space with various input images.

Detailed information such as the system configuration for saving the recorded image once and performing SfM, the width of the margin between the obstacle and the wheelchair model, and the detected depth, width, and height of the barrier are displayed.



Fig. 7: 3D model of verification space (Point cloud display (left), polygon display with texture (right))

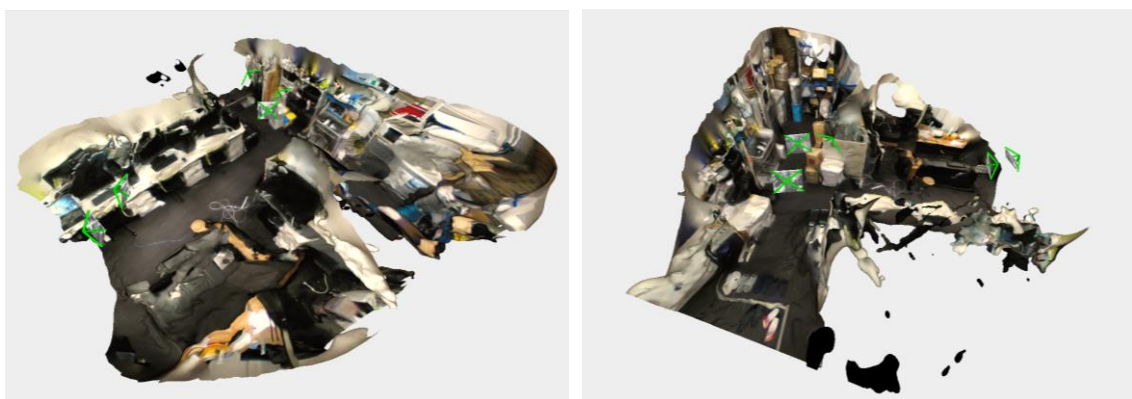


Fig. 8: 3D barrier map

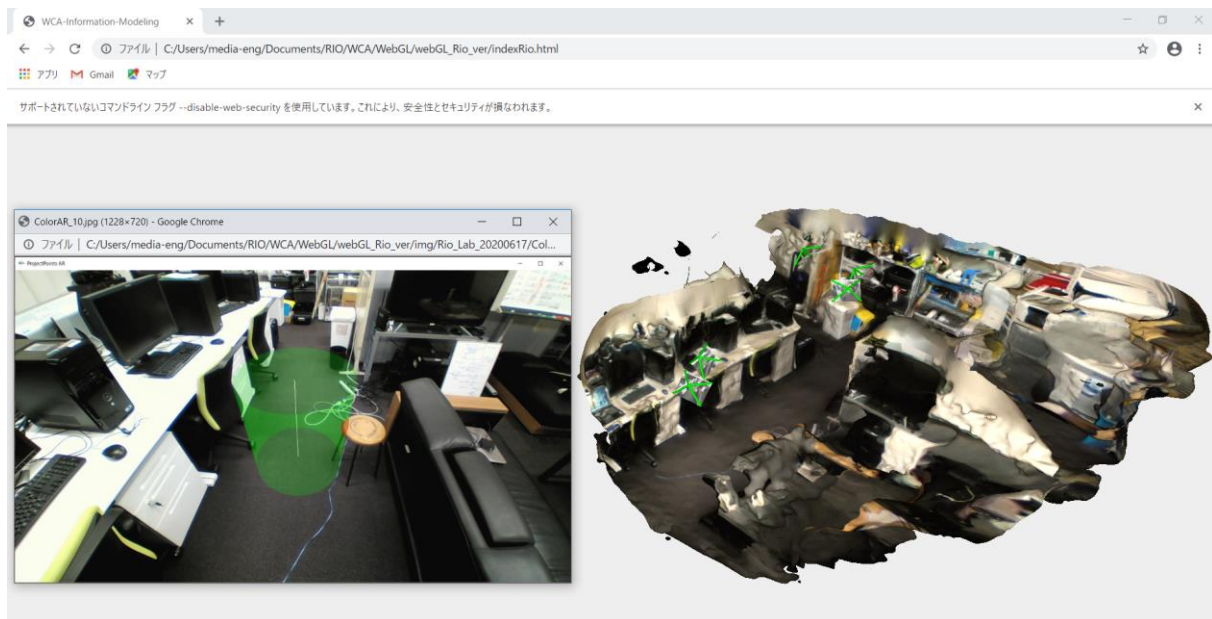


Fig. 9: Detailed results pop up when browsing the browser

5. RELATED WORK

This paper proposed a method to visualize the existence of physical barriers for wheelchair users by using a combination of a wide-angle color camera and depth camera in a way that the instance verification and the compilation of the verified barrier information in a 3D map. Pixel correspondence between different types of cameras allows the barrier position to be accurately displayed in two-dimensional color by merely pointing the camera to the target space. Since it is possible to check the barrier without actually taking out the wheelchair, it is simplified. In addition to being verified, barrier data recording and aggregation will be streamlined while verifying. The visibility will be improved by creating a three-dimensional map, which is expected to contribute to daily barrier-free measures and renovation as facility management. 3D maps are currently created using only the data in the range verified by walking around with a camera.

We plan to implement a function to integrate the 3D map of the barrier verification result, such as the one shown in Fig. 7 into the TLS data of the entire verification space registered in the BIM system in advance. By doing so, it is expected that this system will be facilitated as part of the sustainable maintenance work by the existing BIM.

REFERENCES

- Cabinet Office, Government of Japan (2018), Aged Society White Paper, pp. 2-6. (in Japanese)
https://www8.cao.go.jp/kourei/whitepaper/w-2019/zenbun/pdf/1s1s_01.pdf
- Ministry of Land, Infrastructure, Transport and Tourism, Japan (2017), Life and going out characteristics of the elderly, pp.2-12, www.mlit.go.jp/common/001176318.pdf
- M. Sato (2011), Practice Knowledge of Barrier-free Renovation, Ohmsha, Ltd. (in Japanese)
- Japan Business Association Development Center-Management Research Institute, Survey on management and operation of public facilities (interim report), 2014.
- R. Takahashi, S. Matsushita, H. Dan, Y. Yasumuro, (2018), Physical Barrier Detection for Wheelchair Users with Depth Imaging, JSCE Journal, F3S-0305, 2018.
- R. Lange, P. Seitz, (2001) Solid State Time-Of-Flight Range Camera, IEEE Journal of Quantum Electronics, vol. 37, Issue 3, pp. 390-397.
- M. A. Fischler, R. C. Bolles, (1981) Random Sample Consensus: A Paradigm for Model Fitting with

Applications to Image Analysis and Automated Cartography, Communications of the ACM, vol. 24, no. 6, pp. 381-395.



ISBN:
978-0-9927161-2-7 CONVR2020

